

**S. N. Artekha**

---

**FOUNDATIONS OF PHYSICS  
(critical view)  
CRITICISM OF THE FOUNDATIONS  
OF THE RELATIVITY THEORY**

*4th Edition, expanded and supplemented*

Moscow 2025

The present book is devoted to a systematic critical analysis of the foundations of the relativity theory (RT). The main attention is paid to new logical contradictions of the theory being criticized, since the presence of such contradictions nullifies the value of any theory. The book deals in detail with many controversial and contradictory points of this theory and its corollaries; the logical and physical inconsistency of the fundamental concepts of special and general relativity, such as space, time, the relativity of simultaneity, etc., is demonstrated. The book contains a critical analysis of the interpretation of experiments related to the emergence and establishment of the theory of relativity. The book also presents a detailed critique of the dynamic concepts of the theory of relativity and shows the inconsistency and groundlessness of the seemingly “working” section of this theory – relativistic dynamics.

The present edition is supplemented with a number of new paradoxes, as well as expanded with a discussion of issues related to the topic under consideration and a more detailed analysis of some contradictions.

The given book may turn out to be useful and interesting for students, graduate students, teachers, scientific and technical workers and anyone who independently thinks about the fundamental problems of physics.

# Contents

<b>Preface to the forth edition</b>	<b>5</b>
<b>Preface to the third edition</b>	<b>6</b>
<b>Preface to the first edition</b>	<b>10</b>
<b>1 Kinematics of special relativity theory</b>	<b>16</b>
1.1 Introduction . . . . .	16
1.2 Relativistic time . . . . .	19
1.3 Relativity of simultaneity . . . . .	52
1.4 The Lorentz transformations . . . . .	57
1.5 Paradoxes of lengths shortening . . . . .	60
1.6 The relativistic law for velocity addition . . . . .	74
1.7 Additional criticism of relativistic kinematics . . . . .	85
1.8 Conclusions to Chapter 1 . . . . .	101
<b>2 The basis of the general relativity theory</b>	<b>103</b>
2.1 Introduction . . . . .	103
2.2 Criticism of the basis of the general relativity theory	104
2.3 Criticism of the relativistic cosmology . . . . .	131
2.4 Dark Matter and Dark Energy . . . . .	138
2.5 Gravitational Waves . . . . .	142
2.6 Conclusions to Chapter 2 . . . . .	145
<b>3 Experimental foundations of the relativity theory</b>	<b>146</b>
3.1 Introduction . . . . .	146
3.2 Conclusions to Chapter 3 . . . . .	190

<b>4</b>	<b>Dynamics of the special relativity theory</b>	<b>191</b>
4.1	Introduction . . . . .	191
4.2	Notions of relativistic dynamics . . . . .	194
4.3	Criticism of the conventional interpretation of relativistic dynamics . . . . .	214
4.4	Conclusions to Chapter 4 . . . . .	252
<b>Appendixes:</b>		
<b>A</b>	<b>Analysis of the “proof” for the existence of some invariant velocity</b>	<b>254</b>
<b>B</b>	<b>On possible frequency parametrization</b>	<b>262</b>
<b>C</b>	<b>Possible mechanism of the frequency dependence</b>	<b>271</b>
<b>D</b>	<b>Remarks on some hypotheses</b>	<b>277</b>
	<b>Afterword</b>	<b>289</b>
	<b>Bibliography</b>	<b>296</b>

# Preface to the forth edition

*Look at the root!*  
(Koz'ma Prutkov)

The events of recent years indicate that an active phase of confrontation between Good and Evil, Truth and Lies has begun in the World. In such a situation, it is simply immoral to “saw” the money earned by the sweat of our people to support false theories. On the contrary, the situation should contribute to increasing the personal responsibility of each scientist for the reliability and practical verifiability of his results. It's time to “get out of the convenient protective case” and make your civic choice.

The fourth edition is supplemented with an analysis of such new-fangled inventions as dark matter, dark energy, gravitational waves, with an analysis of a number of modern experiments, as well as a presentation of new key paradoxes, expanded with a more detailed discussion of some nuances and alternatives, supplemented with a detailed explanation of some previous contradictions. In the new edition, literary references have been added [160-207], including two author's work [160, 177].

March 2023

# Preface to the third edition

*My choice is to tell the truth,  
and not force to believe in it.  
(J.-J. Rousseau)*

*One should refuse what appears  
false and shaky, even if we have nothing to replace it.  
A delusion remains a delusion regardless whether we put truth in  
its place or not.  
(Voltaire)*

Since the appearance of the first edition of the book [133], a considerable period has already passed – 14 years. The situation in Russia has slightly improved in terms of opportunities to discuss the issues raised in the book. At some conferences, discussion papers on fundamental issues with criticism of dubious theories (theories of relativity, the Big Bang, relativistic cosmology, etc.) began to be allowed. Some quite official journals (albeit not yet specialized ones of the Russian Academy of Sciences) began to publish critical articles and alternative ideas. Many have ceased to be afraid to have their own point of view and express it publicly. In some places, seminars

are held on a permanent basis, where you can discuss new developments and ideas, including those of a fundamental nature. So, in general, the process of awareness and liberation from self-deception, albeit slowly, but goes on. Over the past time, the author has also published a number of additional articles in English-language journals and materials of international conferences [134-138,152-155], and the amount of communication with Russian and foreign researchers was simply enormous. The author in [201] briefly outlines the course of the anti-relativistic struggle since the emergence of the theories of relativity, writes out many thousands of names of honest researchers who criticized these theories and links to thousands of critical publications.

Many well-known philosophers, mathematicians and physicists belong to the group of critics of the relativity theory, including twelve Nobel Prize winners, i.e. people who made a pioneering contribution to the development of science (and not just those who wrote and rewrote textbooks). The number of eminent opponents of the theory under discussion is comparable to the number of its eminent supporters, so authority is clearly not the judge here. Do not believe that the critics of the relativity theory reject any observable effects! It is easiest to understand what we are against in the following example. Imagine that the sorcerer conjures about the rising of the Sun. We don't say we won't see the sunrise. We only state that the spells of the sorcerer have nothing to do with this sunrise. The theory of relativity is a sorcerer's spell, which has nothing to do with all those effects, the explanation of which the relativity theory ascribes exclusively to itself. Thus, there is no reason to reject the possibility of one's own analysis of this theory and look for real causes and specific mechanisms of phenomena. It must be remembered that, for example, in mathematics, an infinite (!) number of confirmations cannot outweigh even one refutation. That is why relativists should think about precisely those contradictions that opponents have discovered, and not compete in the number of cases where contradictions are deliberately hidden by them. The search for truth always involves a serious attitude to the objections

of opponents.

The position of the True Scientist is perfectly reflected in the following statement. **He who wants to reveal the truth, no less diligently searches for it in the beliefs or assumptions of the opponent. . . He tries to help the opponent find words for his thought that would most accurately express it. True Scientist tries to understand the opponent better than he understands himself. Instead of using every weak point in the opponent's argument to depose, debunk, and destroy the cause he stands for, the participant in the substantive discussion makes an effort to extract from the opponent's statements everything of value that will help reveal the truth.** (T. Kotarbinsky)

How many relate to the search for Truth and to the methods of discussion, like True Scientists? Do not treat the discussion of scientific theories in the spirit of animal instincts – competition in the struggle “for a place under the Sun”! Let's try to move away from the vicious practice of “sweeping problems under the carpet” and, on the contrary, begin to honestly report on inconsistencies in existing physical theories and contradictions with other facts or proven theories, on non-algorithmic techniques, additional ad hoc hypotheses, unresolved physical, philosophical, methodological or math problems. When these problems are honestly highlighted, then any researcher can try to solve them; and if our generation can't do it, then surely succeeding generations will be able to do it. It is important that each new generation does not have to “undercoverly pick these problems out from under the carpet” from scratch, but that the youngest and most productive years could be focused on thinking about and solving them. (For example, math books with titles beginning with “Unsolved Problems. . .” are always inspiring, unlike some “prominent” physicists whining about the end of science.)

The first version of the book was written mainly in thesis, briefly (many points could be supplemented and expanded to the extent of a separate article). But it was presented in such a way that any



person could understand the existing problems, there would only be a desire. And although the materials presented in the first version of the book have not lost their relevance (and no material has been excluded from the new version), nevertheless, it was decided to release not a stereotypical edition, but an expanded and supplemented version of the book. This edition is supplemented by a presentation of new key paradoxes, additional literary references (including in both Prefaces), expanded with a more detailed discussion of a number of nuances, related points and alternatives, supplemented by a detailed explanation of some previous contradictions. This is done on the basis of a biased reading of the book by relativists. Of course, if they have even the slightest desire to understand the essence of the problems raised.

The author does not have the slightest physical ability to convince the six billion inhabitants of the Earth of anything (even one second for each – in the end there will be more human life). And such an unattainable goal is not set. Of course, each person has every right to make his own choice for which he will be responsible, including the choice to “keep in his own juice”. I would just like to remind you that “a collar, a bridle and a whip are always attached to the blinkers”. And in all the rest, this is a personal choice of a human! And I respect and accept any choice, as long as it is conscious.

Starting a critical analysis of both theories of relativity, I wish everyone to remain honest, at least in relation to themselves. So, good luck for searching the Truth!

November 2017

# Preface to the first edition

*This book is dedicated to  
my kind honest wise parents*

Though the technology achievements have been quite impressive in the elapsed century, the achievements of science should be recognized to be much more modest (contrary to “circumscientific” advertising). All these achievements can be attributed, most likely, to efforts of the experimenters, engineers and inventors, rather than to “breakthroughs” in the theoretical physics. The “value” of “post factum arguments” is well-known. Besides, it is desirable to evaluate the real “losses” from similar “breakthroughs” of the theorists. The major “loss” of the past century is the loss of unity and interdependence in physics as a whole, i.e. the unity in the scientific ideology and in the approach to various areas of physics. The modern physics obviously represents by itself a “patchwork blanket”, which is tried to be used for covering boundless “heaps” in separate investigations and unbound facts. Contrary to the artificially maintained judgement, that the modern physics rests upon some well-verified fundamental theories, too frequently the *ad hoc* hypotheses appear (for a certain particular phenomenon), as well as science-like adjustments of calculations to the “required result”, similarly to students’ peeping at an a priori known answer to the task. The predictive force of fundamental theories in applications occurs to be close to zero (contrary to allegations of “showmans from science”). This re-

lates, first of all, to the special relativity theory (SRT): all practically verifiable “its” results were obtained either prior to developing this theory or without using its ideas, and only afterwards, by the efforts of “SRT collectors”, these results have been artificially “attributed” to achievements of this theory.

It may seem that the relativity theory (RT) has been firmly integrated into the modern physics, so that there is no need to “dig” in its basement, but it would be better to finish building “the upper stages of a structure”. One can only “stuff the bumps” when criticizing RT (recall the resolution of the Presidium of the USSR Academy of Sciences, that equated the RT criticism to the invention of the Perpetuum Mobile). The solid scientific journals are ready to consider both the hypotheses, which can not be verified in the nearest billion of years, and those hypotheses, which can never be verified. However, anything but every scientific journal undertakes to discuss the principal issues of RT. It would seem the situation has to be just opposite. Since the basics of this theory are taught not only in universities, but also in school, if there is the slightest doubt, all issues should be seriously and thoroughly discussed by the scientific community in order not to “spoil young souls”.

However, there exists (not numerous but very active and of high rank) part of scientific elite that behaves a strangely encoded manner. These scientists can seriously and condescendingly discuss “yellow elephants with pink tails” (superheavy particles inside the Moon that remained obligatory after Big Bang, or analogous fantasies), but an attempt to discuss the relativity theory leads to such active centralized acts, as if their underclothes would be taken off and some “birth-mark” would be discovered. Perhaps they are simply “ordered to smash urgently”, and they mix everything with dirt, often without even reading the works (thank God, the author “has passed this cup” so far). But any criticism, even most odious, may contain some core of sense (some “rational grain”), which is able to improve their own theory.

RT claims to be not simply a theory (for example, as one of computational methods as applied to the theory of electromagnetism),

but the first principle, even the “super-supreme” principle capable of canceling any other verified principles and concepts: of space, time, conservation laws, etc. Therefore, RT should be ready for more careful logical and experimental verifications. As it will be shown in this book, RT does not withstand logical verification.

Figuratively speaking, SRT is an example of what is called an “impossible construction” (like the “impossible cube” from this book cover, etc.), where each element is non-contradictive locally, but the complete construction is a contradiction. SRT does not contain local mathematical errors, but as soon as we say that letter  $t$  means the real time, then we immediately extend the construction, and contradictions will be revealed. A similar situation takes place with spatial characteristics, etc.

We have been “taught” (by codding) already for a long time that it is possible to live with paradoxes, although the initial “paradoxes” of this theory were rather plausibly reduced by relativists to just some conventional “strangenesses”. In fact, however, every sane man understands that, if a real logical contradiction is present in the theory, then it is necessary to choose between the logic, on which all science is founded, and this particular theory. The choice can obviously not be made in favor of this particular theory. Just for this reason, the given book begins with logical contradictions of RT, and the basic attention is given to logical problems here.

Any physical theory describing a real phenomenon can be experimentally verified according to the “yes - no” principle. RT is also supported by the approach: “what is experimentally unverifiable – it does not exist”. Since RT must transfer to the classical physics at low velocities (for example, for the kinematics), and the classical result is unique (it does not depend on the observation system), the relativists often try to prove the absence of RT contradictions by reducing the paradoxes to a unique result, which coincides with classical one. Thereby, this is a recognition of the experimental undetectability of kinematic RT effects and, hence, of their actual absence (that is, of the primary Lorentz’s viewpoint on the auxiliary character of the relativistic quantities introduced). Various theorists try

to “explain” many disputable RT points in a completely different manner: everybody is allowed to think-over the nonexistent details of the “dress of a bare king” by himself. This fact is an indirect sign of the theory ambiguity as well. The relativists try to magnify the significance of their theory by co-ordinating with it as many theories as possible, including those in absolutely non-relativistic areas. The artificial character of such a globalistic “web” of interdependencies is obvious.

The relativity theory (as a field of activity) is defended, except the relativists, also by mathematicians, who forget that physics possesses its own laws. First, the confirmability of some final conclusions does not prove truth of the theory (as well as the validity of the Fermat theorem in no way implies the correctness of all “proofs” presented for 350 years; or, the existence of crystal spheres does not follow from the visible planet and stars motion). Second, even in mathematics there exist the conditions, which can hardly be expressed in formulas and, thus, complicate searching for solutions (as, for example, the condition: to find the solutions in natural numbers). In physics, this fact is expressed by the notion termed “the physical sense of quantities”. Third, whereas mathematics can study any objects (both really existing and unreal ones), physics deals only with searching for interrelations between really measurable physical quantities. Certainly, we can either decompose any real physical quantity into the combination of some functions or substitute it into some complex function, and then “invent” the sense of these combinations. But this is nothing more than the scholar mathematical exercises on substitutions, which have nothing in common with physics irrespective of their degree of complication.

We will leave for conscience of “showman from science” their intention to deceive or to be deceived (to their personal interests) and shall try to impartially analyze some doubtful aspects of RT.

Note that during the RT life time, the papers have repeatedly appeared, which contained some paradoxes and criticism of relativistic experiments; the attempts were undertaken to correct RT and to revive the theory of ether. However, the criticism of RT had

only partial character, as a rule, and affected only separate aspects of this theory. The current of the criticism and its quality was considerably increased in the end of the last century only (the article and book titles from the bibliography speak for themselves).

It should be recognized that, as against the criticism, there exists the professional fundamental apologetics of RT [3,17,19,26,30,31,33-35,37-41, 158, 159]. Therefore, the main purpose of the author was to present a successive, systematic criticism of RT just resting upon such a fine apologetics of this theory. Following the “generally accepted unspoken tradition”, the basic part of the given book was tested in international scientific journals (*GALILEAN ELECTRO-DYNAMICS*, *SPACETIME & SUBSTANCE*). As a result, the task is gradually being fulfilled, starting with the works [48-55], where the author considered in detail the experiments underlying the theory of relativity, the basic kinematic concepts of special relativity and general relativity, dynamic concepts and consequences of relativistic dynamics. The critical works contain, virtually, no papers on the relativistic dynamics. This fact was one of the main incentives for writing this book.

The present book represents by itself some generalization of published papers from the single standpoint. (Besides, for readers the logical subtleties can always be better grasped in own native language.) To see the most complete “picture of nonsense” we will, whenever possible, try to discuss each doubtful point of relativity theory irrespective of remaining ones. However, due to the limited scope, the book does not contain the citing from textbooks. Therefore, it is presupposed some reader’s knowledge of relativity theory. Besides, often the book considers both the conventional interpretations of relativity theory and possible “relativistic alternatives”. This is done in case someone is tempted to make a different relativistic choice in disputable interpretations and correct the theory of relativity. “Monster” is dead for a long time, and it is not worth to revive it – this is the author’s opinion.

It is rather difficult to choose the successive logic of presentation: for any problem, there arises the desire for presentation of all at-

tendant nuances in the same place of the book, but it is impossible. The author hopes that if a reader can read to the end, majority of impromptu questions and doubts will be consecutively elucidated. The structure of the book is the following. Chapter 1 critically analyzes relativistic notions, like time, space, and many other aspects of relativistic kinematics. Chapter 2 presents the criticism of the basis for general relativity theory (GRT) and for relativistic cosmology. The experimental substantiation of RT will be criticized in Chapter 3. In so doing we shall not consider in detail the experiments pertinent only to electromagnetism or various particular hypotheses of ether (this theme is huge in itself). Instead, we will analyze exclusively some general experiments affecting the essence of RT kinematics and dynamics. Chapter 4 contains the criticism of the dynamical notions of special relativity theory (SRT), results and interpretations of relativistic dynamics. Conclusions are made for each chapter. Appendix A (added to the 3rd edition) analyzes mathematical pseudo-proofs of the necessity of the existence for a certain invariant velocity. In the remaining Appendixes, particular hypotheses are considered.

September 2003

# Chapter 1

## Kinematics of special relativity theory

### 1.1 Introduction

Traditionally, standard SRT textbooks begin with a description of the allegedly then existing crisis of physics and experiments that preceded the emergence and establishment of SRT. However, there exists an opinion [38] that SRT was originated as a purely theoretical “breakthrough” having no need of any experimental substantiation. The author does not agree with such the opinion, since physics is primarily destined to explain the really existing world and to find interrelations between observed (measurable) physical quantities. Nevertheless, we begin the book with a theoretical consideration of relativistic kinematics, but not with an analysis of experiments. The matter is that several theories can try to interpret the same observed phenomenon in quite different ways (this has always been and always will be in physics). However, it is common practice to abandon the theory manifesting logical contradictions. The history of physics demonstrates repeated changes of conventional interpretations for many phenomena. And it is not to be believed that the elapsed century was the last one for these changes.

In textbooks on general and theoretical physics, and in the pop-



ular scientific literature, there exists almost advertising support of special relativity theory (SRT). This is expressed in theses like: “about the Practical Importance of SRT”, “about the Uniqueness and Foundation of all Mathematical Derivations and Corollaries from SRT”, “about the Simplicity and Elegance of all SRT Formulas”, “about Full Confirmation of SRT by Experiments”, “about the Absence of Logical Contradictions in SRT”, etc. But if we keep aside issues of particle dynamics (they will be discussed in Chapter 4), and consider only kinematic notions, then the “Practical Significance of SRT” will be obviously zero. The uniqueness and theoretical validity of SRT can also be questioned [58,65,102,111,132,144,145,148-151,156,157]. In works [48-50,52,134-138,152-155], a series of logical contradictions, related to the basic concepts of space, time, and relativity of simultaneity, was analyzed in detail, and the complete lack of logical grounding for SRT was proved. Also, the complete lack of experimental grounding for SRT was shown (these issues will be considered in Chapter 3 of the book); and as some demonstration of the non-uniqueness of SRT solutions, the possibility of a frequency parameterization of all SRT results was described (such a parameterization was not the main purpose of the cited work; it will be presented in Appendixes B and C as a particular hypothesis).

In this Chapter, criticism of kinematic concepts of SRT will be presented in detail, and attention will be given to some “plausible” errors from textbooks. All these circumstances force us to return to classical concepts of space and time, as advanced by Newton. He formulated these notions in *Mathematical Principles of Natural Philosophy* as a brilliant generalization of works of precursors (including ancient Greeks). Relativists aspired to destroy the former conceptions at any cost (carping, basically, on the word “absolute”) and to allege “something new and great”. But they could present no definitions for notions of time, space and motion, but only manipulated with the mentioned words. Therefore, it is worthwhile to give at least brief comments on Newton’s classical concepts in the Introduction [28].

Proceeding from practical demands of natural science, Newton

understood that any creature is “excellently familiar with the mentioned notions and practically uses theirs” (for example, insects that are incapable of abstract thinking in opinion of people). So, these notions are the basic ones, i.e. they cannot be defined through anything. Then, it is possible to give only an enumeration of “things” that will be meant by these notions or will be used in practice and to separate the abstraction that will be implied for idealized mathematical calculations. Because of this, Newton clearly separated absolute, true, mathematical time or duration (all these words simply are synonyms in this case!) from relative, seeming or ordinary time. Thus, time means the mathematical comparison between duration of the process under investigation and duration of the standard process. In classical physics, the possibility of introducing the universal time has not been directly connected with the obvious restriction on the speed of signal transmission. More likely, obtaining the universal time was connected with the possibility to recalculate it from local times with reasonable exactness. In perfect analogy to this, Newton separated the absolute space notion from the relative one, distinguished absolute and relative place, and distinguished between absolute and relative motions. If the search of relationships of cause and effect is believed to be one of the goal of sciences, then the important positive moment of the classical approach consists in a separation of an object under investigation from the rest of the Universe. For example, in the overwhelming majority of cases, “the motion of observer’s eyes” does not exert any noticeable influence on a concrete proceeding process and, so all the more, on the rest of the Universe. Certainly, there exist “seeming effects”, but to concentrate just upon the process under study, they can be eliminated by the graduating of devices, recalculations etc. The classical kinematic notions was actually introduced by Newton just for the determination of registration points and standards independent of the process under investigation. This founds the grounds for the common description of different phenomena, for the joining of various fields of knowledge and for the simplification of the description. Also classical notions intuitively coincide with ones given to

us in sensations: it is stupid not use they – it equals “to try walking on your ears”. Therefore, if suddenly some time starts to depend on some process, it means that the wrong standard was chosen or the concepts of “time” and “clock” were confused. A centuries-old development of sciences (from ancient Greeks) shows that the classical kinematic concepts lead neither to internal logical contradictions nor to discrepancy with experiments.

Now we shall pass to “the things, created by relativists” in this field, and consider logical contradictions in the fundamental notions of “space” and “time” in SRT. We begin with the conception of time.

## 1.2 Relativistic time

Now we remind, how the erroneousness of RT kinematic concepts can be proved most easily. For the “yes-no”-type results, only one of different evidences of two observers could be true. Therefore, at least one of moving observers would be wrong in mutually exclusive judgements. However, the situation can always be made symmetrical with respect to the third resting observer. Then his evidences will coincide with the classical (checked for  $\mathbf{v} = 0$ ) result, and in this case, the evidences of both first and second observers should transfer to this result. However, since both the first and second observer moves relative to the third one, all three their evidences will be different. Owing to situation symmetry, both the first and second observer occurs to be wrong in his judgements, and only the third, resting observer describes the true (classical) result. Exactly in this manner, the inconsistency of the relativistic concept of time (the time is irreversible!) was proved in the modified paradox of the twins [48,51], as well as the inconsistency of the “relativity of simultaneity” concept [50]. (Note that the space-time diagram [33] does not change the physics of even usual paradox of the twins: all additional aging of Earth’s inhabitant arises suddenly (!), when the motion of an astronaut changes at the far point and is only geometrically expressed as the change of lines of simultaneity).

We will begin the analysis of the theory of relativity with the traditional classical paradox of the twins.

### The classical paradox of the twins

The well-known plausible “explanation” of the traditional paradox of the twins is to indicate the asymmetry of the situation: two reference systems are unequivalent due to the presence of acceleration for one of the twins when turning its rocket. Unfortunately, “a magic of mathematics” (with the involvement of a change in lines of simultaneity or the faith in the general theory of relativity) hypnotizes many researchers. However, some games with mathematical symbols are not enough for physics: a physicist is engaged in the search for the causes of phenomena, mechanisms for their implementation and the physical meaning of the quantities used. This is what physics differs from mathematics. We will analyze the role of accelerations.

We recall that by analogy with classical time, the relativistic intrinsic time of any object does not depend on the speed of the movement of this object itself. Let the first twin remain in the inertial reference system without gravity, the second twin is the cosmonaut-traveler. Firstly, we remind in accordance with the textbooks of SRT that **according to each brother’s opinion** before acceleration (before the turn), the **other brother** should be **younger**. Note this *initial state* – until acceleration. Generally speaking, the situation in SRT is completely symmetrical for both twins during the entire flight with the exception of the time of accelerations (this state of affairs is accepted by textbooks). Therefore, in the opinion **of each of the brothers**, an increase in age **to another** brother should be less than his own increase in age for these (non-accelerated) parts of the flight. Since only the brother-astronaut was accelerated, it was he who (according to relativistic textbooks) is declared younger than his brother-homebody at a meeting. This *is the final state*. But since rejuvenation (movement of intrinsic time **backward**) is impossible, then during the acceleration time, the brother-astronaut

could not become more younger than before acceleration, in order that change his difference in the age relative to his brother (in opinion of the brother-homebody) from a plus by minus (remember the previously noted “initial state” before acceleration). This means that if you believe in the results of SRT, the brother-homebody must become many more older than the brother-astronaut (in order to compensate for the initial opposite difference in age in opinion of the brother-astronaut). Since the only impact was acceleration, then, from the viewpoint of the brother-astronaut: he himself accelerates, and another brother is aging faster! (Whether we should forbid for astronauts and athletes to accelerate so that everyone around is less old?) What is the reason for such a “phenomenon-at-distance”? Also and the mechanism is absent (the acceleration of the twin 2 cannot affect to the aging of the twin 1 at a large distance).

Secondly, as it can be seen from Figure 1.1, the lengths of sites with accelerations  $|OA|$ ,  $|BC|$ ,  $|CB|$  and  $|AO|$  can be chosen the same for different flights (they can be fixed), but the lengths of the segments of flight  $|AB|$  and  $|BA|$  with the same large constant speed can be chosen significantly different for different flights. For example, we choose a flight at a distance of 50 light years in one case, and in the other case – for 100 light years. Obviously, **one and the same acceleration** can not explain the arising **age differences of two pairs** twins (for  $v \rightarrow c$ :  $t_2 - t_1 \sim 50$  years and  $t_4 - t_3 \sim 100$  years old, respectively). Otherwise, causality is lost: the acceleration has the same value, but its influence is different for different pairs of twins! By developing this thought, you can constantly change the acceleration sign ( $\langle v \rangle = 0$ ) and there will be arbitrary additional aging (then the SRT formulas for time dilation with constant speed have no sense).

Thirdly, the brother-homebody can take part only in accelerated movements: there at the segments  $|OA|$  and  $|AK|$ , and back. These segments are completely identical to the same segments of the brother-astronaut: forward  $|OA|$  and  $|BC|$ , back  $|CB|$  and  $|AO|$ . The brother-homebody can start at the calculated moment of the

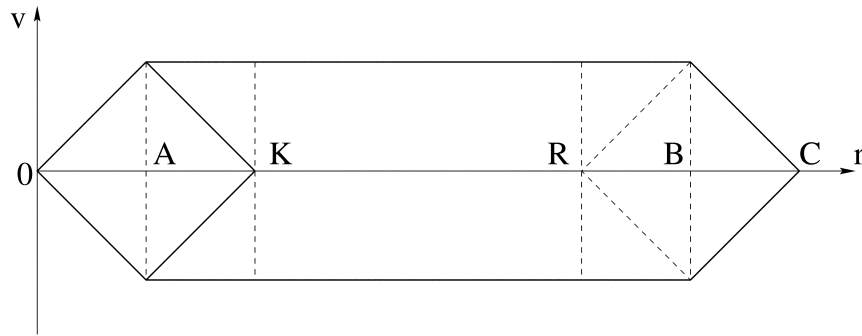

Figure 1.1: The role of accelerations in the paradox of the twins.

flight of the brother-astronaut through the  $R$  point. As a result, only the displacement of the start time of accelerated movements will be observed. Therefore, the key difference in accelerations disappears, since both twins were involved in the same (according to their own times) accelerated movements.

Fourthly, let us now assume a different situation. The first brother remains on the ground and is under the influence of the usual gravity (acceleration of a free fall  $\mathbf{g}$ ). The second brother accelerates with the same acceleration of  $\mathbf{g}$  only in the areas  $|OA|$ ,  $|BC|$ ,  $|CB|$  and  $|AO|$ . Note that relativistic speeds can be achieved with such acceleration during the order of the year. It is obvious that during this year of accelerated movement will not occur either accelerated aging or accelerated rejuvenation. Therefore, the acceleration of  $\mathbf{g}$  affects only the small part of his flight on the astronaut. A brother-homebody could even for the time of the uniform flight of his brother-astronaut leave into space so as not to experience the attraction of the Earth  $\mathbf{g}$ , then the situation for them would be completely identical, because according to the general relativity theory, the influence of gravity with a value of  $\mathbf{g}$  and the effect of acceleration  $\mathbf{g}$  are equivalent. Who will be younger now? In all previously considered cases, there is no mechanism for the influence of acceleration of one of the twins on the age of the other twin. Thus, the

coincidence of mathematical symbols with pre-required results of SRT is nothing more than a fit, and the initial “explanation” of the twin paradox by acceleration (Einstein, Pauli, Bourne, Laue) can be passed into a dusty archive of the history of science.

Accelerations and speeds can be different for different astronauts in the process of their movement, but you can always organize a meeting at one point, and, according to each, the age of the same object will be different, which is ridiculous. A detailed analysis of the theory of relativity is now continue considering the modified paradox of the twins.

### **The modified twins paradox**

We would preliminarily remind that in classical physics results are obtained by one observer can be used by any other observer (including investigators not participating in experiments). In such a case, our goal is to formulate some symmetric setting of a problem with results which are evident from the common sense. Relativists, who constantly renounce common sense and believe in the universality of relativity, would then simply have to consider and compare with each other: 1) and the results of the experiment for each of the participants, 2) and the relativistic ideas (calculations) of each participant about the results of observations and calculations for every of other observers! Only then the relativists would be able to show the absence of contradictions and the observability of their relativistic effects. However, for some reason, they do not seek to establish the Truth in this matter, and those few who have done such an analysis either stated the absence of relativistic effects for schemes with two observers (and declared this), or found contradictions for a larger number of observers (most honest and fearless even went over to the camp of critics of the relativity theory).

Some relativists deliberately confuse the time of the event and the time of receiving information about the event. Therefore, we will also make a preliminary remark about the “relativistic icon” – Einstein’s synchronization method. Even the ancient primitive sci-

ence would not stoop to the nonsense of paired time matching, since any method of pairwise synchronization uses some theoretical representation (and depends on it). For example, in ancient times, if the king, who went on a long hike, received news of the birth of his son, and the messenger got to him six months, then the king, of course, understood that the son was born not at the time of receiving the news, but six months ago (mistakes were avoided because people used an **independent remote source of signals – the Sun** – for objective time counting). In Einstein’s subjectivist method, the time for spatially separated observers is also set not at the time of signal reception, but **by calculation** (otherwise, “creeping” time zones depending on distance would have turned out, and no synchronization). Einstein’s synchronization itself **postulates in advance the equality of the speed of light in any two opposite directions**. Moreover, no synchronization actually occurs: each of the participants artificially **attributes** to the other participant the time **according to own calculations** and then lives with this **faith** in his head. And he analyzes all thought experiments based on this belief, i.e. compares his own data with his own calculations! What kind of objectivity is there?! Let the first of the mutually resting observers send a signal to the second one that he set zero time at the time of sending the signal. Having received the signal, the second observer cannot yet set any agreed time! Therefore, it instantly reflects this signal back, remembering this time moment by its unsynchronized watch. Now, having received his own signal back, the first observer can use **his watch** to **calculate** the time when the signal was received by the second observer, **but** using the **hypothesis of isotropy for the speed of light** (i.e., the equality of the time of light propagation there with the time of light propagation back), by dividing the elapsed time in half ( $2T/2 = T$ ). However this hypothesis should be tested experimentally (otherwise, this synchronization method is an artfully “embedded” paraphrase of the postulate about the constancy of the speed of light). In order for the second observer to still be able to set some agreed time, the first observer also instantly reflects his signal. And only after receiving



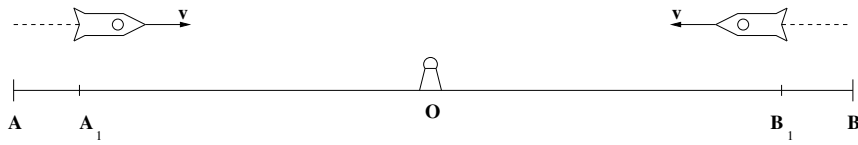

Figure 1.2: The modified twins paradox.

this twice reflected signal, the second observer can **calculate** when there was zero time on the watch of the first observer and the current time  $3T$  ( $2T/2 = T \Rightarrow T + 2T = 3T$ ), and can set his watch according to these calculations, i.e. he will be able to synchronize the time. Herewith, he also must **believe in the hypothesis** of the isotropy for the speed of light. Now both of them will have  $3T$  on their watches. In the future, when we will say that the time of mutually resting separated observers is synchronized (according to Einstein), we will mean that just such a procedure has been done. (Although, if there exists an ether, and it has a non-zero velocity component along the line connecting these observers, then there will be no isotropy of the speed of light.)

Let us now turn to the paradox itself. Let two colonies of Earth's inhabitants  $A$  and  $B$  be at some large distance from each other (Fig. 1.2). A beacon  $O$  is at the middle of this distance. It sends a signal (the light sphere), and when it reaches both colonies (simultaneously), each launches a spacecraft piloted by one twin. The laws of acceleration (to reach a large equal speeds) are chosen equal in advance. At the time each twin passes the beacon, at a high relative velocity, each will believe that his counterpart should be younger. But this is impossible, since they can photograph themselves at this instant and write their age on the back side of a picture (or even exchange pictures by the digital method). It is nonsense, if wrinkles will appear on a pictured face of any astronaut during the subsequent deceleration of another one. Besides, it is unknown beforehand if one of astronauts will wish to move with acceleration in order to turn around and catch up to the other one (to the question

“on the role of acceleration in the twin paradox”).

This paradox can be more reinforced and be formulated as a paradox of coevals – people born in the same year. SRT declares not a transfer of the start of the counting time (for example, as in time zones on Earth), but a change of the course of time itself (duration). The laws of acceleration and the subsequent constant speeds are beforehand selected to be the same for the both missiles. Let the family of astronauts launch from each colony (on a signal from the beacon), and let the baby was born on each ship immediately after the cessation of all accelerated movements. Immobile relative the beacon observers at points  $A_0$  and  $B_0$  can confirm the fact of the appearance of babies 1 and 2 respectively. The time of the three resting observers ( $A_0, B_0, O$ ) was synchronized in advance (for example, by the Einstein method described above), and, if necessary, the common start of the time can be calculationaly shifted by one and the same value, for example, when receiving a signal (according to each observer’s own clock). And at the moment of the birth of babies, time is synchronized for all five participants: zero time is set for each of the two baby-astronauts (time will simply count their age), for both observers-witnesses at points  $A_0$  and  $B_0$  (they shift their starting time on zero and send a signal to the observer on the beacon about how much it is necessary to shift its starting point of time) and for the observer on the beacon, who will shift his starting point of time later, after receiving a signal about it (and about how much it is necessary to shift the starting point). However, the planet Earth is quite large, and always we can find someone who was born exactly that many years ago (when observers in  $A_0$  and  $B_0$  saw the birth of baby astronauts), and we can invite him to the beacon (as the third stay-at-home baby with his childhood photos and biographical videos). These babies-astronauts are chosen to compare ages. The entire previous history of movement (up to the points  $A_0$  and  $B_0$ , respectively) does not exist for them. Babies differ in that they moved relative to each other with constant speed all the time. Before the meeting at the beacon, they passed the same distance in comparison with each other, both from the viewpoint of the observer

at the beacon ( $d = |OA_0| = |OB_0|$ ), and from the viewpoint of each of them about their own path. This is a pure experience precisely to compare the duration of the time intervals and to verify SRT. Let, for example, the flight of the child 1 with a constant speed lasted 18 years by the clock in the first rocket. Therefore, from the SRT viewpoint, the first child will reason in the following manner: “All 18 years of my life, the second child moved at a high speed relative to me, which means his age should be less than mine”. Besides, if he will count out the age of the second baby starting from the moment of the receipt of signal from  $B_0$ , then he will believe that he will see infant in arms at the meeting. But the second baby will reason about the first baby in the same manner. However, due to complete symmetry of movement, the result is obvious: the age of such “astronauts” will be the same (which will be confirmed by the resting observer on the beacon).

Flying over non-stop near the beacon, astronauts can take photos of themselves, sign their age, and digitally exchange photos. Can it be that the face in the photograph of one astronaut will begin to grow old during the deceleration of the second astronaut? In addition, it is not known in advance which of the astronauts will want to move with acceleration in order to turn around and catch up with the other.

However, everyone can continue their previous path and supplement it with an equal path traveled, flying away from a single center, and fly at a constant speed up to points  $B_0$  and  $A_0$ , respectively, so that even the total path traveled by them is clearly the same. Due to the symmetry of the problem, observers at rest at points  $A_0$  and  $B_0$  will confirm the simultaneous arrival of both rockets at these points. So who will be younger? Or did they not move relative to each other?

Some relativistic mathematicians prefer to fit calculations to the results of special relativity using Lorentz transformations. To do this, they have two tricks. The first is the concealment of the meaning of the physical quantities used: some of them are directly measurable **for one specific fixed observer**, but the other part for

the same observer is just calculated quantities already tied to belief in SRT. Thus, this agreement with oneself according to the rules of SRT is pseudoscientific masochism. For this paradox, the first trick does not work, since the participants meet at the same point. The second trick is related to the displacement of the initial time for ever-existing clocks (sometimes their coordinates) in the Lorentz transformations. This trick in this paradox also does not work, since it is impossible to move the initial time back – the baby simply did not exist then, and it is impossible to go forward either – its age is clearly visible with one’s own eyes. In classical physics, the concept of time is consistent and both pairwise and collective comparisons of elapsed time (or clock readings) are allowed. This is no longer the case in STO. The situation is extremely obvious for a symmetric problem.

I) Each participant will be able to measure (see) his own time during the experiment on a wrist watch. It will be the same for all five observers when the astronauts fly past the beacon (or when they fly by distant observers at points  $B_0$  and  $A_0$ , respectively), otherwise the principle of relativity itself would be violated, i.e. there would be no SRT base at all.

II) They will also see the same their own time and the same someone else’s time with their own eyes when they meet. But then, for example, the first child must find out and compare, according to SRT:

III) What should be the estimated time allegedly passed on the beacon, “while the beacon flies to child 1 at a speed of  $\mathbf{v}$ ”,

IV) What should be the estimated age of child 2 while it was flying towards child 1 at a speed  $\mathbf{V}_{AB}$ ,

V) What age would child 2 assign to him,

VI) What age would the observer at the beacon assign to him,

VII) What age would the observer at the beacon attribute to child 2,

VIII) What age would child 2 attribute to the observer at the beacon.

And each of the participants in the experiment must answer these

eight questions. As a result, for each participant, the calculated and experimental times differ (not all are the same); for example, there are such as

$$\frac{d}{v}, \quad \frac{d}{\gamma v}, \quad \frac{d(1 + v^2/c^2)^2}{\gamma v}$$

and others, and they contradict at least someone's observations or expectations.

To avoid such relativistic chicanery (tricks), we will compare the halves of the whole that are obvious from the point of view of each observer according to any theory. So, let each coeval-astronaut fly at the same constant speed the distance between mutually resting observers-witnesses at points  $A_0$  and  $B_0$  (and the coeval-homebody lived near the lighthouse  $O$ ). We will mark the observed quantity with the first lower index of the one who is observing, and the second lower index is who he is observing when determining this value. The quantities after the meeting at the beacon will be marked with another stroke from above. Then  $t_{11}, t_{22}, t_{33}$  is their own time (*equiv* age) when meeting the coevals near the beacon, respectively, astronaut 1, astronaut 2 and homebody 3. Each of them will see their own time (age) in the mirror, and the time of each other will be seen on his face (by the number of wrinkles), i.e. the information is experimental and verifiable, not calculated. For example, everyone is looking at cosmonaut 1 near the beacon:

$$t_{11} = t_{21} = t_{31},$$

similarly, when all three look at the second or third coeval:

$$t_{22} = t_{12} = t_{32}, t_{33} = t_{13} = t_{23}.$$

Due to the symmetry of the problem for the astronauts 1 and 2 (relative to the stay-at-home witness 3 at the beacon), we have:

$$t_{31} = t_{32}.$$

Next: the astronaut 1 flies to the beacon (to homebody 3), but with the same modulo velocity, the homebody 3 flies to the astronaut 1,

hence

$$t_{13} = t_{31},$$

otherwise the principle of relativity itself would be violated (i.e. the base for SRT). Similarly, when describing the relative motion of astronaut 2 and homebody 3:

$$t_{23} = t_{32}.$$

Thus, all these times (ages of coevals) turned out to be the same: both their own times and visible times to any observer in relation to any other participant:

$$t_{11} = t_{21} = t_{31} = t_{22} = t_{12} = t_{32} = t_{33} = t_{13} = t_{23} \equiv \tau_0.$$

From the SRT viewpoint, this is at least strange (all the proper and observed times by other participants turn out to be the same, despite the fact that the three systems moved relative to each other at different speeds, so they had to be connected by relativistic formulas), but the main contradiction is hidden not here, since this situation is only our choice five observers (and time synchronization). The contradictions manifest themselves further when the flight of astronauts 1 and 2 continues to the points  $B_0$  and  $A_0$ , respectively. From the viewpoint of any of these three participants (observers), the second half of the way for him is equal to the first half of the way, the speed has not changed, hence

$$t'_{11} = t_{11} = \tau_0, \quad t'_{22} = t_{22} = \tau_0, \quad t'_{33} = t_{33} = \tau_0.$$

But from the viewpoint of any of these observers to any other observer, he will also fly the second half of his path equal to the first half of the path at the same speed as before (even if we believe in relativistic reduction of distances, then the second half of the shortened path is equal to the first half of the shortened path). From here

$$t'_{12} = t_{12} = \tau_0, \quad t'_{21} = t_{21} = \tau_0, \quad t'_{13} = t_{13} = \tau_0, \quad t'_{31} = t_{31} = \tau_0,$$

$$t'_{23} = t_{23} = \tau_0, \quad t'_{32} = t_{32} = \tau_0.$$

Thus, all nine new values for the second half of the experiment again turned out to be equal to each other and equal to the previous nine values of the first half of the experiment; that just we needed. Note that some equalities between these nine times could be written from the principle of relativity or from the symmetry of the problem:

$$t'_{12} = t'_{21}, \quad t'_{31} = t'_{13}, \quad t'_{23} = t'_{32}, \quad t'_{31} = t'_{32}.$$

It is this real age of astronauts 1 and 2 that fixed observers will fix (will see firsthand) at the points  $B_0$  and  $A_0$ , respectively:  $T_1 = t_{11} + t'_{11} = 2\tau_0 = T_2 = t_{22} + t'_{22}$  (since the watches in  $B_0$ ,  $A_0$  and  $O$  were synchronized in advance, these motionless observers will tell the homebody 3 this time of the end for the inertial part of the experiment, and he will be able to find photos and videos of his life at that moment  $2/\tau_0$ ).

And now, for the second half of our experiment, let's recall relativistic fairy tales about the usual paradox of twins, when one of them stays on Earth (in our case, it's homebody 3), and the second one flies on a rocket (in our case, it's astronaut 1 or 2 – any). In all textbooks, it is stated that as long as the flight continues at a constant speed (before turning with acceleration), from the viewpoint of a stay-at-home, an astronaut will be younger, and from the viewpoint of an astronaut, a stay-at-home will be younger. Moreover, the values of

$$t'_{11} \neq t'_{12} \neq t'_{13}, \quad t'_{21} \neq t'_{22} \neq t'_{23}, \quad t'_{31} \neq t'_{32} \neq t'_{33}$$

should differ according to relativistic formulas. It turned out to be a contradiction: the calculated relativistic time has nothing to do with real time, recorded by all participants personally! Thus, the presence of a non-zero relative velocity of inertial systems cannot by itself lead to a different course of time: there are no objective reasons or implementation mechanisms for this pseudo-effect. If relativists are trying to secretly slip us sliding time zones instead of objective reality, depending on the changing distance between observers, then

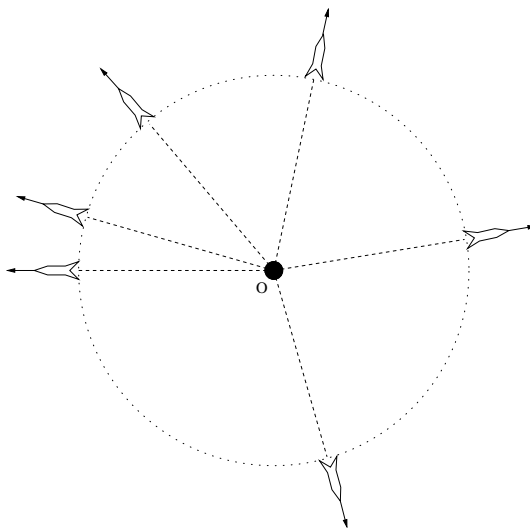

Figure 1.3: The paradox of “n twins”.

what is the greatness of false SRT theory here - to force us to view the World in a “crooked Troll mirror”?

Let us consider now a modified paradox of “n twins” (Fig. 1.3). Let them fly in different directions from the same center  $O$ , so that all the departure angles are different in any pair combinations (irregular  $n$ -gon). The schedule of velocities and accelerations is chosen the same beforehand (all spacecrafts are always “situated” at some sphere with the center  $O$ ). Because of vector character of these quantities, all relative velocities and accelerations will be different in pairs. By the opinion of some selected astronaut, each another astronaut must grow old to a different age (and this takes place from the viewpoint of each astronaut), which is impossible (again all astronauts can photograph themselves before each acceleration and after it). On the other hand, for the  $(n + 1)$ th twin remaining in the center, the scheme is completely symmetrical, and the ages of the astronaut brothers will be the same. The simplest special case



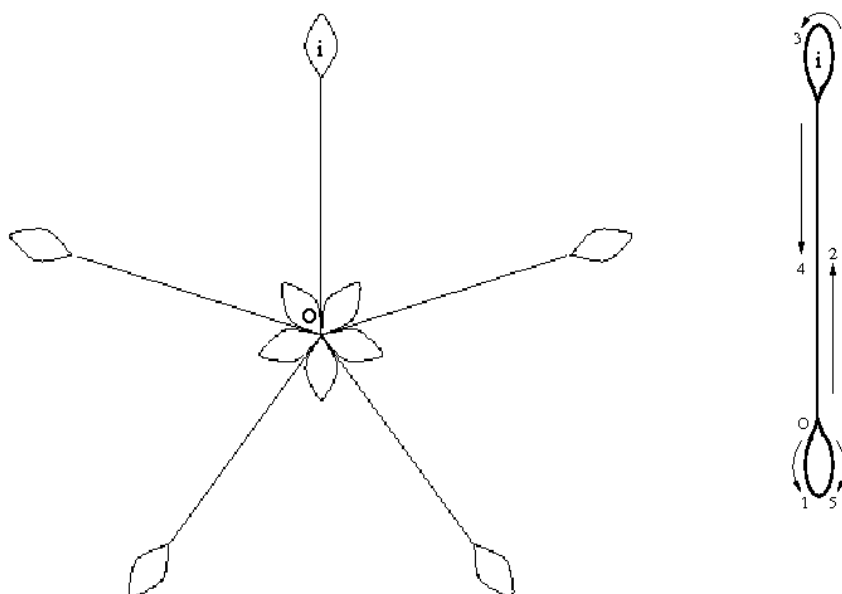

Figure 1.4: Flight on a symmetrical scheme of a flower type.

is obtained, if one brother remains in the center, while the other two fly apart in opposite directions (at an angle of  $180^\circ$ ). Note that the idea of introducing a third observer into some more complex flight scheme was proposed earlier (see [156]).

Let us consider in more detail such a symmetrical flight pattern of a flower type (Fig. 1.4), including rectilinear segments of motion at a constant speed (inertial segments). The movement of each rocket consists of five sections. Starting from one and the same center  $O$  with one and the same acceleration (for example,  $\mathbf{g}$ ) along identical loops (accelerating segments 1), the rockets again fly through the same single center  $O$ . Consequently, the time spent by each rocket ( $i$  or  $j$ ) to pass through such accelerating sections will be the same both from the viewpoint of an observer at rest in the center and from the viewpoint of any of the astronauts:  $t_{1i} = t_{1j}$ .

Further, the rockets fly uniformly and rectilinearly (inertial segments 2). Then they turn along identical turning loops (sections 3). For turning loops it is also easy to prove that  $t_{3i} = t_{3j}$ , since any of the loops can be obtained from another loop or from loops 1 using some parallel translation and rotation. Further, the rockets again fly uniformly and rectilinearly (inertial segments 4 coincide with segments 2, only the movement occurs in the reverse direction). Finally, the movement ends after passing through the brake loops (sections of trajectory 5 coincide with sections of trajectory 1). Deceleration is carried out in the reverse order with respect to acceleration:  $t_{5i} = t_{5j} = t_{1i} = t_{1j}$ . The scheme is completely symmetrical, which means that the total travel time for all astronauts will be the same:  $t_i = t_j$ . It is clear that the above reflects the homogeneity and isotropy of space. Since the movement of each rocket consists of movements along these five sections, then we finally get for movements along rectilinear trajectories (inertial sections):  $t_{2i} + t_{4i} = t_{2j} + t_{4j}$  for any  $i$  and  $j$ . However, speed is a vector quantity and relative speed depends on the choice of  $i$  and  $j$ . And the relativistic formula, which reflects the time dilation, contains only the square of the relative velocity. Consequently, according to SRT, the course of time must be different for different astronauts, which leads to contradictions both between the astronauts themselves, who started and finished simultaneously, and with the data of a stationary observer. Thus, the presence of relative velocity in itself cannot be the cause of time dilation.

Attempts look naive when “explanations” of different versions of the classical twins paradox are “made” with artificially fabricated auxiliary diagrams: relativists are again cunning and do not check results as a matter of contradictions from the viewpoint of all observers (will somebody claim that the Lorentz transformations are insufficient ones, but diagrams present something more thing? really?!). “To put it mildly”, physics and mathematics are slightly different sciences. Possible, someone could be interested how a rhombus, a parallelogram, a triangle and other pure geometric drawings can be turned or transformed to pseudo-scientifically

rescue the SRT. But all these recommendations resemble the proud INSTRUCTIONS “how one can scratch the right-hand ear with the left heel, when this leg is twice wound round the neck, and, doing so, how one can provoke the same sensations (only they must be elucidated beforehand!) as for the normal man” (which satisfies his requirements in more natural manner). But even with this “state of affairs”, the following fact attracts attention. In classical physics, any logically consistent path leads to the same objective result (every observer can imagine the arguments of any other observer and even use them). The matter is quite different for SRT: some of the completely similar reasonings have to be arbitrarily postulated as incorrect (that is, the choice of the path must be adjusted to fit the classical results). A wonderful theory turns out: “we read here, we don’t read here, we turn it over like this here, here we turn it inside out” and, as the song says, “and in the resting things, beautiful marquise, everything is fine, everything is fine”. This is cleverly concocted!

### The time paradox

Now we shall pass to the time paradox for moving systems. For “resolving” it, the Lorentz transformations are often used: they allow one to put in correspondence to one time instant  $t$  the whole continuum of times  $t'$ . Note, that if we compare the time intervals, then the procedure of synchronizing the time reference point is unimportant. Let us have four clocks  $((1, 2); (1', 2'))$ , spaced similarly in pairs and synchronized in their own systems  $K$  and  $K'$  (Fig. 1.5). The synchronization can, for example, be performed by an infinitely remote source located on the axis perpendicular to the plane of all four clocks (it will be further outlined in the subsection on “establishing the universal absolute time”). Then for any time intervals we have

$$\Delta t_1 = \Delta t_2, \quad \Delta t'_1 = \Delta t'_2 \quad (1.1)$$

However, according to the Lorentz transformations formulas, from the point of view of observers in system  $K$  (near the clocks), at the

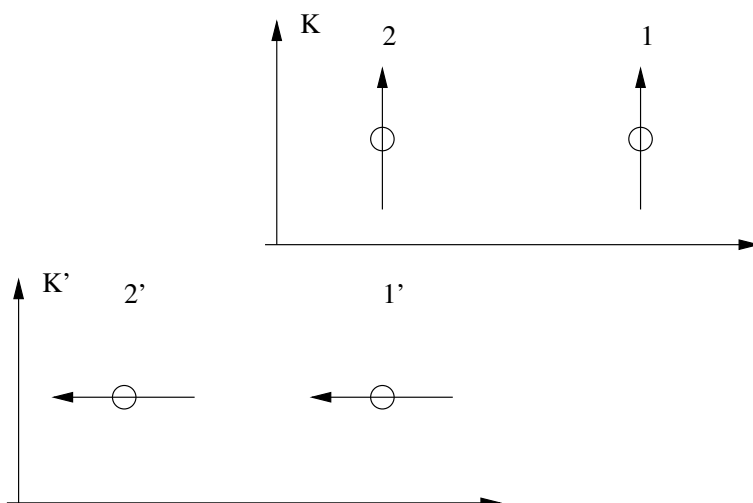

Figure 1.5: The time paradox viewed at  $t = 0$ .

time of coincidence of clocks we have (Fig. 1.6):

$$\Delta t'_1 < \Delta t_1, \quad \Delta t'_2 > \Delta t_2, \quad (1.2)$$

i. e. inequality (1.2) contradicts equality (1.1). A similar contradiction with (1.1) occurs if the inequalities are written from the point of view of observers in system  $K'$  (near the clocks). Even the values of differences of time intervals will be different. Thus, these four observers will not be able to agree among themselves, when they meet at one point and discuss the results. Where then is the objectiveness of science?

### The paradox of antipodes

The erroneousness of SRT is proved very simply by the whole life of mankind on the planet Earth. Let us consider the elementary logical contradiction of SRT – the paradox of antipodes. Two antipodes situated at the equator (for example, one person in Brazil,

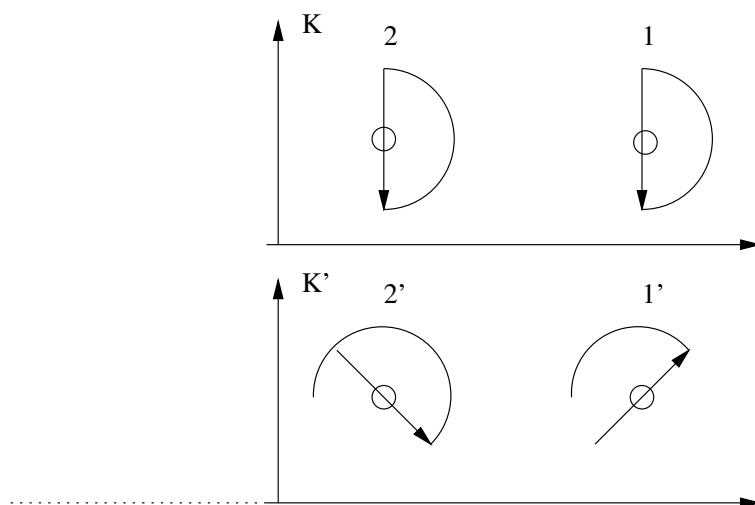
Figure 1.6: The time paradox viewed at  $t = t_1$ .

the other one – in Indonesia) differ by the fact, that due to the Earth rotation they move relative to each other at constant speed at each time instant (Fig. 1.7). Therefore, despite the obvious symmetry of the problem, each of these persons should grow old or grow young relative to another one. Does the gravitation hinder? Let's remove it and place each of our "astronauts" into a cabin. Each person can determine the time on such a "round robin" (as well as on the Earth) from the direction to the far star, which is motionless with respect to the system center, and from the period of intrinsic rotation of this "carousel". The running of time will obviously be identical for both "astronauts". The time can be synchronized by the calculation method knowing the period of revolution (all these problems are technical, rather than principal). Let's increase the linear speed  $v \rightarrow c$  for amplifying the effect (for example, in order that according to SRT formulas the difference in time be "running up" 100 years for one year). Does the centrifugal force (acceleration) hinder? Then we shall increase radius  $R$  of the round carousel, so

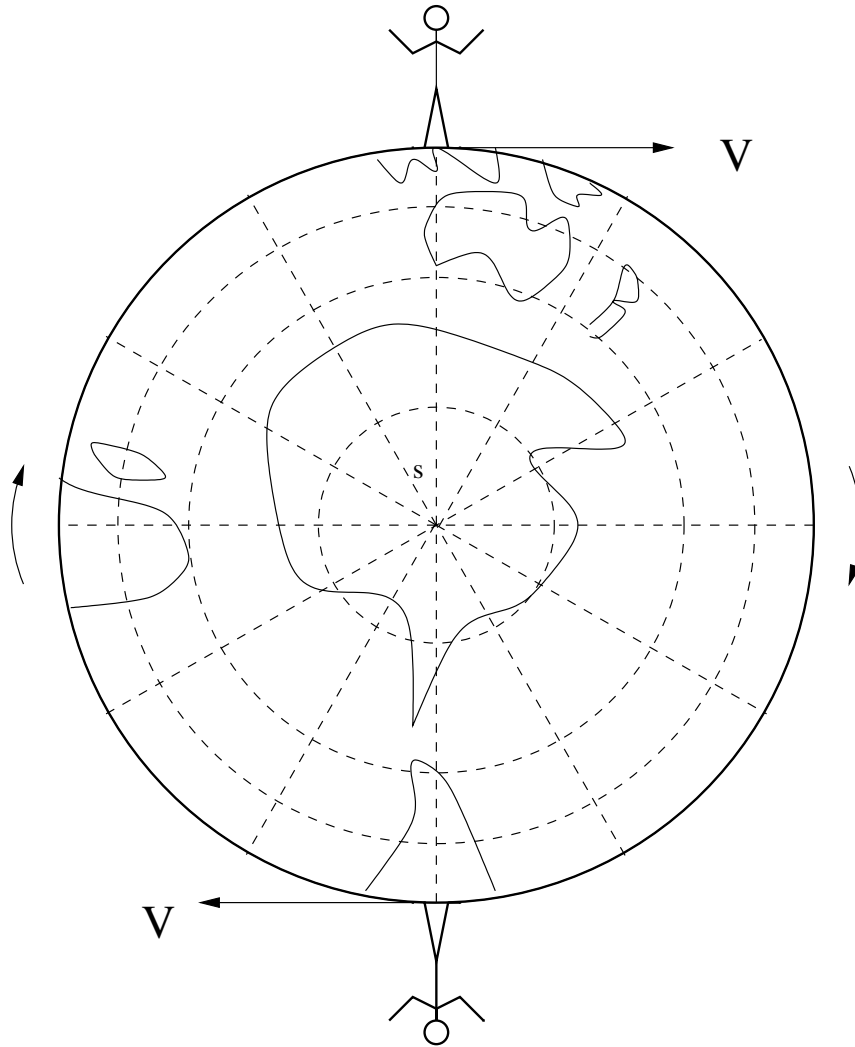

Figure 1.7: The paradox of antipodes.

that  $v^2/R \rightarrow 0$  (for example, in order that even for 100 years the overall effect from such an acceleration be many orders of magnitude lower, than the existing accuracy of its measurement). In such a case none of experiments can distinguish the motion of antipodes from rectilinear one, i.e. the system cannot be experimentally detected as non-inertial one throughout the test. It is worthless for relativists to fight for the principal necessity of inertiality of the system, since the boundless mathematical rigor “cuts down” any theory. Recall that even in such the strict science as mathematics (in the justification of the theory of real numbers, for example), it is used the notion of the number  $\varepsilon$  given beforehand, which can be chosen as small as one likes. In case discussed, for the strict mathematical transition, the ratio of a centrifugal acceleration  $v^2/R$  to the centrifugal acceleration  $a_c$  on Earth can be made less than any arbitrary value of  $\varepsilon$  through choice of a large radius of the “round carousel”  $R$  (for instance, we can choose  $\varepsilon \sim 10^{-10}$  or  $\varepsilon \sim 10^{-100}$ , whereas all SRT experiments were made on the Earth with  $\varepsilon \sim 1!$ ). And, further, if you trust in the relativity (it is indifferently either according to SRT or according to Galileo, since we compare time durations), then you can transfer the motion of one of antipodes, in a parallel manner, closer to the other antipode and forget about the round carousel model at all. Obviously, the reverse mental operation can always be performed for any two mutual opposite motions with the same speed as well. Namely, we can perform parallel transfer of one of trajectories to a great distance  $R \rightarrow \infty$  and “bridge” the motions by some “round carousel”. So, will “the patient be alive or dead” after some years? And who is more pleasant for you – the Brazilian or Indonesian? The full symmetry of the problem and full failure of SRT! Note, generally speaking, that the unified character of time cancels the principality of the issue of its synchronizing: the watch can, for example, be worn with yourself. Some doubts on “near inertial” motions will be discussed below in Chapter 3.

And for those relativists who “principally” will try to close eyes to themselves and to others to the possibility of passing to large  $R$ , we can suggest inscribing a regular  $n$ -gon ( $n \geq 3$ ; in each angle

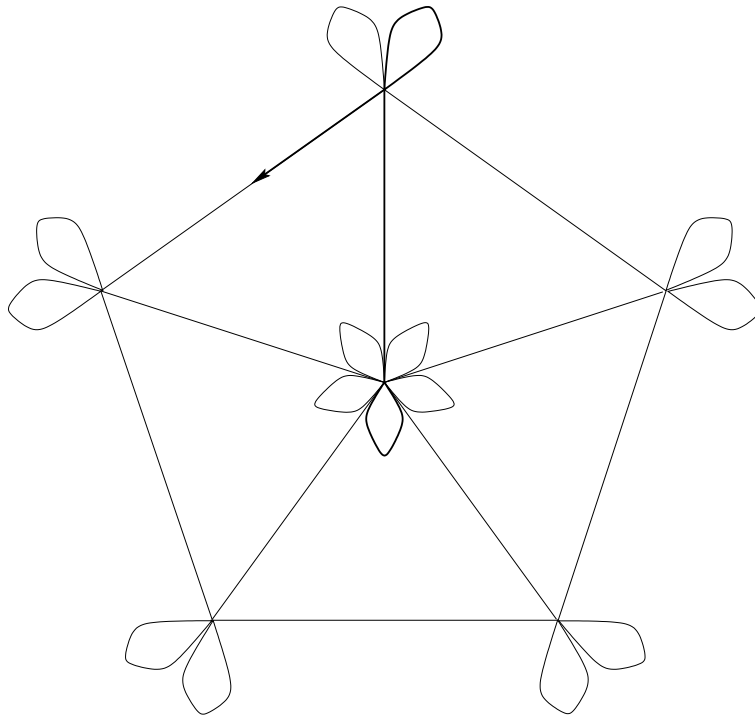

Figure 1.8: The other symmetrical model of flight of “a flower type”.

a fixed observer is located) and to consider now purely rectilinear motions of rockets with astronauts along the sides of this  $n$ -gon (even identical loops for a set of identical velocities using the same “terrestrial” accelerations  $g$  can be equally docked to the angles of this  $n$ -gon). It is obvious that for a stationary observer (for example, in the center of a circle), all these inertial systems of rockets are absolutely equal in rights and the course of time in rockets will be the same, despite the movement of rockets relative to each other. Here we can also draw the obvious symmetric scheme of “a flower type” for the possibility of the simultaneous start and finish of astronauts at the center of a circle (see Fig. 1.8).



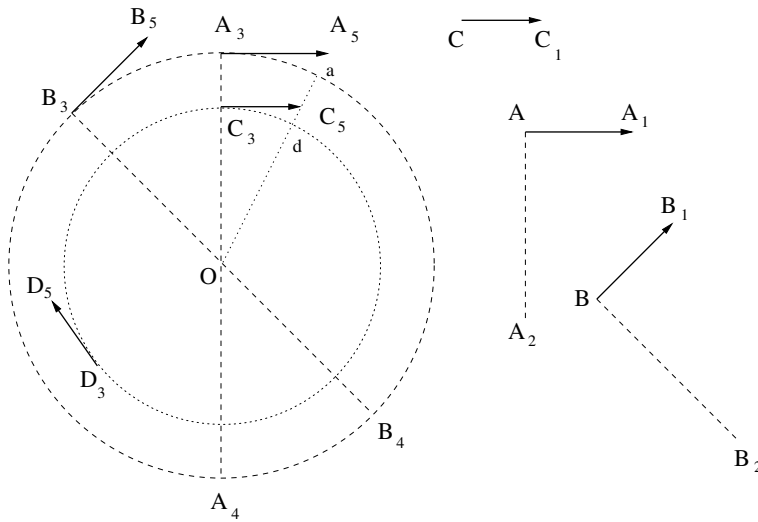

Figure 1.9: The model of a round carousel for arbitrary planar motions.

Since we will compare the time course (but not time beginning), we can use the equality of the time course for any two mutually resting objects. Then, the model of “ a round carousel” can be easily generalized to the case of planar motions with arbitrary (in directions and values) velocities of objects. This is purely geometric trivial problem (Fig. 1.9). For example, let us have two rectilinearly moving objects, which are pictured in Fig. 1.9 with the velocity vectors  $\overrightarrow{AA_1}$  and  $\overrightarrow{BB_1}$ . The both velocities possess the same modulo  $v$ , the value of which tends to the speed of light  $v \rightarrow c$ . Let us choose an arbitrary point  $O$  in the space. We choose an arbitrary point  $O$  in space and draw a circumference with the center at the point  $O$  and with such a radius  $R$  that the centrifugal acceleration is less than some predetermined small value  $\varepsilon_1$  (for example, the existing acceleration measurement accuracy ):  $v^2/R < \varepsilon_1$ , i.e.  $R > v^2/\varepsilon_1$ . We draw the straight line  $AA_2$  which is perpendicular to the straight line  $AA_1$ . Thereafter, through the point  $O$ , we draw the straight

line  $A_3A_4$ , which is parallel to the straight line  $AA_2$ . At a point of intersection of this straight line and our circumference we draw the velocity vector  $\overrightarrow{A_3A_5}$  which is parallel to  $\overrightarrow{AA_1}$  and has the same absolute value  $|\overrightarrow{AA_1}|$ . Factually, we simply made a parallel translation of the motion with velocity  $\overrightarrow{AA_1}$ . Making the analogous procedure with the motion  $\overrightarrow{BB_1}$ , we obtain motion with velocity  $\overrightarrow{B_3B_5}$ . Now both the motions are placed at the same circumference and they cannot be distinguished from inertial motions with an existing accuracy. Due to obvious symmetry of the scheme of the motion, the course of time will be equal for these objects. For example, the course of time can be measured with periodic flashes, which occur from the center  $O$  of the circumference. Let us now take a rectilinear motion characterized by the velocity vector  $\overrightarrow{CC_1}$  which is parallel to  $\overrightarrow{AA_1}$ , but with a different modulus. Let's make a parallel transfer of motion and get  $\overrightarrow{C_3C_5}$  (here, we take the radius of the circumference  $|OC_3| = R|\overrightarrow{C_3C_5}|/|\overrightarrow{A_3A_5}|$ ). In this case, we see that two objects (which characterized by velocities  $\overrightarrow{A_3A_5}$  and  $\overrightarrow{C_3C_5}$ ) will move along concentric arcs of circumferences  $A_3a$  and  $C_3d$ , remaining at the same distance from each other along the radii of the circumferences. (In Fig. 1.9, only for visualization, large arcs are shown, that is, all angular values are drawn as increased; in fact, all arcs in terms of angular measure will be very small and indistinguishable from straight lines.) Again, time can be "measured" by periodic flashes from the center  $O$  (how many light spheres will pass through the circumference  $C_3d$ , the same their quantity will pass through the circumference  $A_3a$  – the light spheres cannot "disappear, be added, be condensed or hidden anywhere"). It is obvious that the course of time for such objects will be the same. In this case, we can continue the circumference passing through the point  $C_3$ , and, at any new its point, we can draw the vector  $\overrightarrow{D_3D_5}$ . This vector is tangent to the circumference and equal in modulus to  $|\overrightarrow{C_3C_5}|$ . Again, the objects with velocities  $\overrightarrow{D_3D_5}$  and  $\overrightarrow{C_3C_5}$  are placed at the same circumference, and, due to the symmetry of the problem, the course of time will be the same. Thus, on the example of planar motions with velocities  $\overrightarrow{A_3A_5}$  and  $\overrightarrow{D_3D_5}$ , or  $\overrightarrow{B_3B_5}$  and  $\overrightarrow{C_3C_5}$ , we proved that the

course of time has to be independent on the the absolute value of velocities and on the direction of velocities of objects, but it remains one and the same. Generalization to the three-dimensional case is trivial for point objects. To start with, we will transfer the beginning of the first velocity vector to the beginning of the second velocity vector. Thereafter, we can draw a plane through these intersecting straight lines. On the plane obtained, we can carry out all previously described actions. Thus, the course of time is independent on any motions of inertial systems at all.

### Circular motion of missiles

Consider another key paradox. Imagine that two identical rockets (or satellites) fly together (connectedly) in identical circular orbits around a star. Obviously, that according to SRT (and the general theory of relativity), time flows the same way in both systems of missiles binded to each other. Let us now consider the second situation (Fig. 1.10): we have separated the binded rockets and rotated one of the orbits by  $180^\circ$  with respect to an arbitrary diameter. Now the rockets move along the same their orbits with the same speeds, but rotate around the star in opposite directions, meeting twice for each revolution (at points *A* and *B*). Obviously, the influence of the effects of the general relativity theory (GRT) on the course of time for both rockets remained unchanged. But there arises a contradiction with the influence of SRT on the course of time: now **the rockets are moving relative to each other** all the time with the non-zero speed (remember the relativistic formula involving the square of the speed). What nanoseconds are there, it smells of “rejuvenating apples” here! Since the number of revolutions can be arbitrary, it remains only to decide who to award the “Grand Prize” - to become younger? To the one who moves against or clockwise? And from where to look? In fact, it is obvious that the task is completely symmetrical, and no difference in time can exist. This means that such an effect of SRT as time dilation is completely absent. Centrifugal acceleration (non-inertiality) interferes with relativism? No

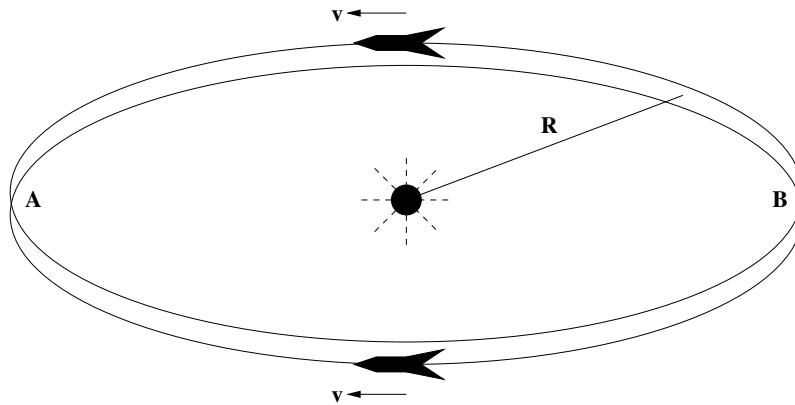

Figure 1.10: Movement in circular orbits.

problem! Let the linear velocity of rockets be close to the speed of light. We will increase the radius of the orbits  $R$  so that the ratio of the centrifugal acceleration of rockets  $c^2/R$  to the centrifugal acceleration on the Earth's surface  $a_c$  is less than any given beforehand value  $\varepsilon$ . For example, you can select  $\varepsilon \sim 10^{-10}$ . But all the results allegedly confirming relativism were obtained on Earth with  $\varepsilon \sim 1$ ! Again, relativists should not fight for absolute inertiality, otherwise SRT will not even have a subject for research at all!

### Paradox of a sawn ruler

Let us recall Galileo's proof (by dividing the whole into parts) of the fact that doubling the mass of a body cannot double the acceleration of its fall, and formulate the paradox of a sawn ruler. Consider four identical rulers (Fig. 1.11). For clarity, the ruler  $A$  at rest lies at the start, and the ruler  $B$  at rest lies at the finish. The  $C$  ruler will move during the experiment, being sawn into two equal parts (1 and 2), and identical  $D$  ruler will move as a whole during the experiment. All laws of motion are preselected to be the same. To begin with, we separately consider the movement of the first half of the ruler  $C - 1$ .

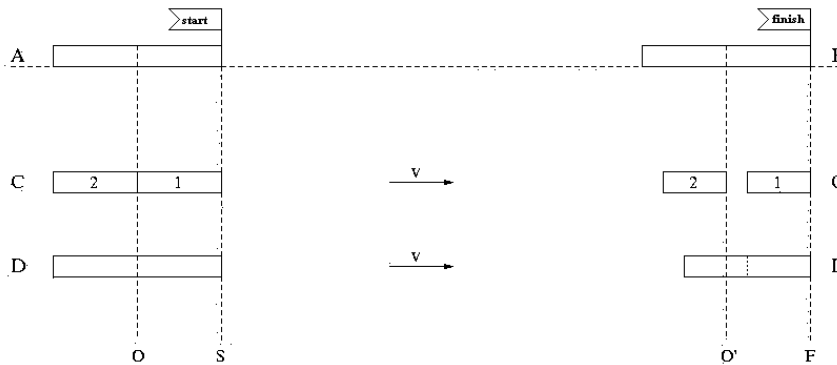

Figure 1.11: Paradox of a sawn ruler.

This ruler begins to move with a constant acceleration, reaches a high speed  $V$ , flies with such a constant speed and crosses the finish line  $F$  with its right end. We suppose now that the second half of the ruler  $C - 2$  starts moving simultaneously with the first half and moves according to the same laws (as  $C - 1$ ). Then its right end will cross the line  $O'$  at the moment of crossing the finish line  $F$  by the first half of the ruler  $C - 1$ . This is an obvious result: the situation with the second half of the ruler  $C - 2$  differs from the situation with the first half of the ruler  $C - 1$  only by the parallel transfer of the origin, since the right end of the half of the ruler is transferred parallel from the line  $S$  to the line  $O$ . But for the uncut ruler  $D$  the situation will be completely different, since the ruler reaches the finish line as a whole. There arise a logical contradiction. First, how can the ruler  $C$  know about its cut? Second, a cut of zero width cannot, according to SRT, turn into a non-zero spatial gap. In addition, the ruler can be divided into an arbitrary number of parts and it will simply be impossible to fit (mental shift to save SRT) to get rid of all the resulting gaps at the same time.

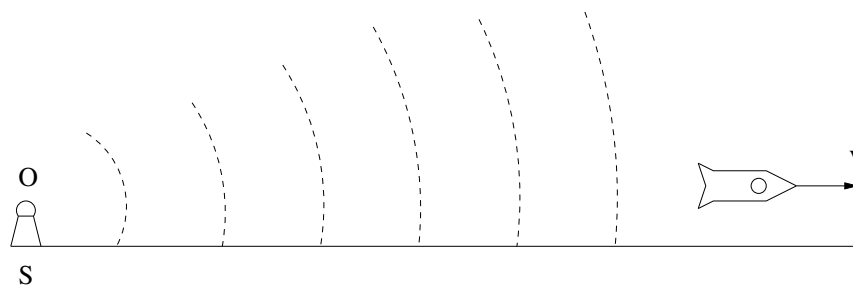

Figure 1.12: The interchange of signals of intrinsic time.

### The universal absolute time

The notion of time is broader, than the dimensional factor in transformation laws, and bears much greater relation to the local irreversibility of processes. First, a single-valued “binding” of time to the motion of a body does not take into account internal processes, which can be anisotropic, pass at various “rates” and characterize the local irreversibility (each such rate is in different manner added geometrically with the velocity of a body as a whole). Second, the binding of time only to the velocity of transmission of electromagnetic interactions does not take into account other possible interactions (which can propagate in vacuum) and actually implies electromagnetic nature of all phenomena (the absolutisation of electromagnetic interactions). Later we shall consider, how the universal absolute time can be introduced.

When we introduce the notion of intrinsic time (actually, subjective time), the following methodological point seems important: we should not calculate intrinsic time of an alien object according to our own rules, but rather “ask” this object itself. Consider the following experiment (Fig. 1.12): Let an observer be situated in the motionless system  $S$  at point  $O$ , where a beacon is installed. The beacon flashes each second (as a result, the number of flashes  $N$  equals the number of seconds passed at point  $O$ ). Let an astronaut (in moving system  $S'$ ) be launched from point  $O$ . Then, when mov-

ing away from point  $O$  the astronaut will perceive flashes more rarely (at lower frequency), than before launching (in fact, beacon's "time slowing" takes place). But upon approaching to the beacon the astronaut will see the opposite, flashes will occur more frequently than before launching (now we have beacon's "time speed-up"). For  $v < c$  it is obvious that the astronaut can neither outstrip any flashes, nor go around any of flashes (light spheres). So regardless of his motion schedule and trajectory, upon returning to point  $O$  the astronaut will perceive equally  $N$  flashes total, i.e. all flashes, which have been emitted by a beacon. Therefore, each of these two observers will confirm that  $N$  seconds have passed at the beacon.

If the astronaut on board the spacecraft will also have a beacon and will signal about the number of seconds passed on his watch, then no disagreements will arise concerning astronaut's time as well. The situation appears to be fully symmetrical (for the twins paradox, for example). When meeting at the same point, all light spheres will intersect opposite observers (their quantity can neither increase, no decrease). This number is equal to  $N$  - the number of seconds passed for both observers.

Consider now the problem of establishing the universal absolute time. (Of course, if we measure the time by beatings of our own heart, it will be subjective and will depend on the internal and external conditions). The attempt to introduce individual "electromagnetic time" and to absolutize it - this is a return to the past. However, even at that time the people could synchronize time, despite miserable data transmission rate (by pigeon-post, for example), because they used a remote source of signals (the Sun or stars). Let us imagine the following mental experiment (Fig. 1.13). The remote source  $S$ , which lies on a median perpendicular to segment  $AB$ , sends signals periodically (with period  $T$ ). At the time of signal arrival to point  $O$ , two recording devices (1 and 2) begin to move mirror-symmetrically (at velocities  $\mathbf{v}$  and  $-\mathbf{v}$ ), while reflecting from  $A$  and  $B$ , with period of  $2T$ . Velocity  $v$  can be arbitrary (we can choose the appropriate distance  $|AB|$ ). In spite of the fact, that at each time instant the devices are moving relative to each

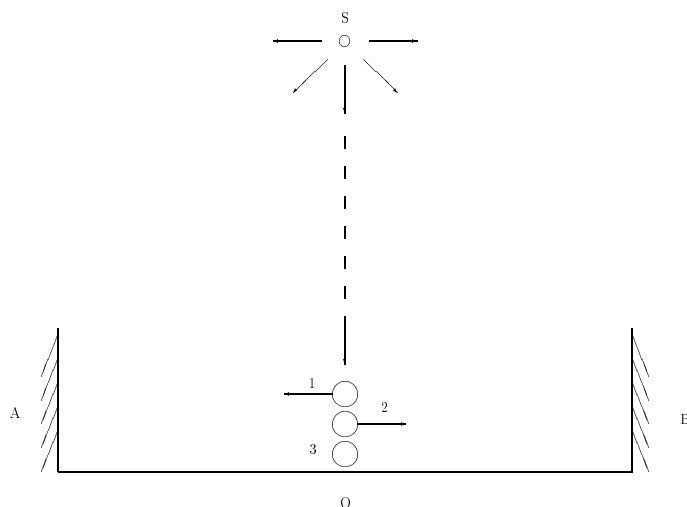

Figure 1.13: An infinitely remote source for establishing unified absolute time.

other at speed  $2v$  (except the reflection points), the signals will be received at the same time, namely, at the time of passing by point  $O$  (observer 3 can be placed at this point). The time, determined in such a manner, will be universal (at point  $O$ ), i.e. the same for all three observers. In order to make the following step, we note that for deriving the transformation formulas in the SRT, it is sufficient to consider the relative motion along a single straight line (since the systems are inertial). By choosing the large distance  $|SO|$  we may assure that the time difference between signal arrival to point  $O$  and to points  $A$  and  $B$  be smaller than any pre-specified value. As a result, to the given accuracy the time will be the same for the whole chosen segment  $AB$  regardless of the velocities of motion of observers 1 and 2. Thus, the infinitely remote source of signals, situated perpendicular to the direction of relative motion of systems, can serve as a watch counting the universal absolute time (which is the same regardless of the inertial system of reference). The ques-



tion on the change in the observed direction of signal arrival will be presented below lest a temptation are going to arise in “far-fetched” use of the aberration allegedly demonstrating the change in the wave front direction.

### Additional remarks

The next methodological note is as follows: if the Einstein method is used for synchronization, the notion of time becomes limited. First, only one of two independent variables - spatial coordinates or time - remains independent, whereas the other is associated with the state of motion (subjectivism) and properties of light speed (but why is it not associated, for example, with the speed of sound or with the velocity of Earth, etc.?). Second, since the independent determinations of spatial coordinates and time are required for determination of velocity, light speed itself becomes indeterminate quantity (immeasurable, postulated).

As relativists like to potter with idle inventions! One of such the “Great” idle inventions of the relativity theory is a light clock (for 100 years anybody did not try to construct a pre-production model at all and will never try to make it!). And it is not because that it is impossible to create ideally flat, ideally parallel, ideally reflecting mirrors. That is why, that we cannot observe “TICK-TOCK” sideways as it is described by the SRT fantasies. Such a clock “works” to first “TICK” and ceases to be “identical”, as a photon at the moment of “TICK” registration should finally be reacted (be absorbed). Nevertheless, we will return “to ours relativists”, which often use a “light clock” for demonstrating the time slowing effect [35] (Fig. 1.14). However, in exactly the same manner we can also consider a periodically reflecting particle (or a sound wave) at speed  $u \ll c$  and obtain the arbitrary time slow-down  $\tau_0/\sqrt{1-v^2/u^2}$ . It is known, that the orthogonal velocity components can be described independently: the horizontal motion at velocity  $\mathbf{v}$  relative to an instrument will in no way influence the vertical oscillations of a particle moving at former velocity  $\mathbf{u}$ . The question on experimental

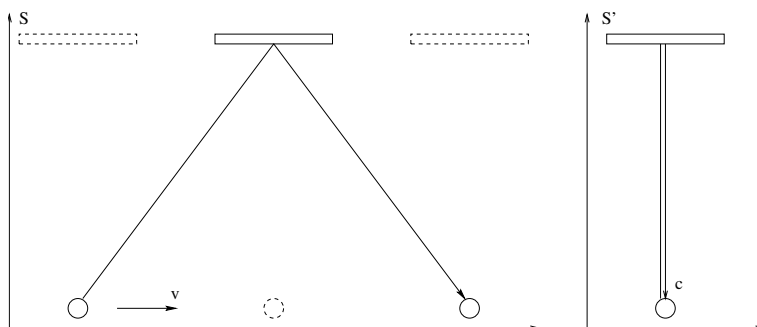

Figure 1.14: The light clock.

verifications of the postulate of light speed constancy will be analyzed in Chapter 3.

The time slowdown in SRT is nothing else, but the apparent effect. Remind that for a sound the duration of a hooting of trumpet  $\Delta t$  also depends on the velocity of a receiver relative to a source (a trumpet), but nobody makes the conclusions on time slowdown from this fact. The fact is that observer's "decision" to move at any velocity is in no way bound causally with sound emitting processes (as well as with other processes in a trumpet). Let a singer be continuously singing a song in the resting atmosphere, and his twin brother be moving away from a singer at about the speed of sound  $v_s$ :  $\alpha_1 \equiv v/v_s \approx 1$ , and then he will move toward a singer (with the same ratio  $\alpha_1$ ). Though the song will be distorted, nobody had yet recorded more rapid aging of a singer. Let now we modulate with the same song the light in pursuit of the twin brother, who departed on a rocket at almost the speed of light, but with the same numerical value  $\alpha_2 \equiv v/c = \alpha_1 \approx 1$ . Now the twin brother will listen the same distorted song. Why the situation must change in this case, and the "home seating" brother must grow old? And, if some living organism will be characterized by some certain radiation frequency, that distinguishes him from the dead organism, then, because of your motion (because of the Doppler effect) whether you really will

first certify the death of an organism, and then his resurrection? Or it is necessary to postulate the change of objective characteristics of an object, which is not bound with you causally?

Now we make some comments concerning Einstein's time synchronization method. The transitivity of time synchronization by Einstein's method takes place for the trivial case of three mutually resting points only. If, however, the points (not lying on the same straight line) belong to the systems moving relative to each other in different (not parallel) directions, then the synchronization procedure can become uncertain: For what time instant the watch can be considered to be synchronized? For the beginning of the procedure, for its termination or for an intermediate instant? Even for the points lying on the same straight line Einstein's method rests upon a completely unverified (experimentally) concept of equality of the speed of light in one and in a directly opposite direction. Factually, the synchronization turns out to be either a semi-calculated procedure, or a multi-iteration process, because the synchronization is performed for two selected points only. These deficiencies are absent in the method of synchronization with a remote source disposed on the perpendicular bisector [48]. It allows one to synchronize the time experimentally (rather than computationally), without attracting additional hypotheses, with a prescribed accuracy at once on the entire given segment (even on a flat section).

Now we proceed to units of the time measurement. Certainly, for a separate phenomenon within the framework of some mathematical model any customary quantity can be described in various measurement units and in various scales (both uniform and non-uniform, for example, in the logarithmic scale). This is basically determined both by the convenience of description for the given model, and, as in the case of generalization, by the possibility of using the same quantities for the other physical phenomena and mathematical models (the matching of various fields of physics). However, Taylor and Wheeler's [33] sarcasm concerning the "sacred units" is completely inadequate. Certainly, we can introduce the conversion coefficient for converting the time into meters. But this factor is not obliged

to be the speed of light: for example, it can be the velocity of a pedestrian. Both aforementioned velocities have, quite equally, no relation to acoustic, thermal phenomena, to hydrodynamics and to many other fields of physics. Generally speaking, in such a manner, it is possible to express all quantities (such as mass, charge, etc.) in meters. However, all these “various meters”:

- 1) can not be summed up,
- 2) are not interchangeable,
- 3) very rarely (or never) appear in some joint combinations and
- 4) the same combination is unsuitable for various phenomena.

(For example, the interval has relation only to the law of light propagation in vacuum.) All quantities can be made pure numbers (and we must separately track all these physical values). But in any case physics will not become mathematics. Physics does not study all illusory combinatorial “worlds” of equations, but only that rather small amount of them, which is realized in the nature (the basic problems of physics are: What interrelations are realized in the nature, why and what are the consequences of this?).

### 1.3 Relativity of simultaneity

Now, after criticism of the fundamental concept of time for SRT, we continue the analysis of the logical basis of this theory and consider the subsidiary notion of the “relativity of simultaneity”. Recall the mental experiment from SRT: a train  $A'B'$  passes along a railroad at speed  $v$ . Suddenly, lightning strikes the railroad bed ( $C$ ) just opposite to the train center  $C'$  (at the moment of coincidence  $C = C'$ ). Then, in the coordinate system centered on the moving train, the flashes will simultaneously arrive at points  $A'$  and  $B'$ , whereas for a motionless observer the flashes will simultaneously arrive at points  $A$  and  $B$  (with the middle at point  $C$ ); but up to this instant, points  $C$  and  $C'$  (the middles of segments) will move away to some distance from each other. But a similar situation is possible in classical physics as well, if we want to transmit information from points  $A', B', A, B$  to the new single point  $D$  (or, conversely, to

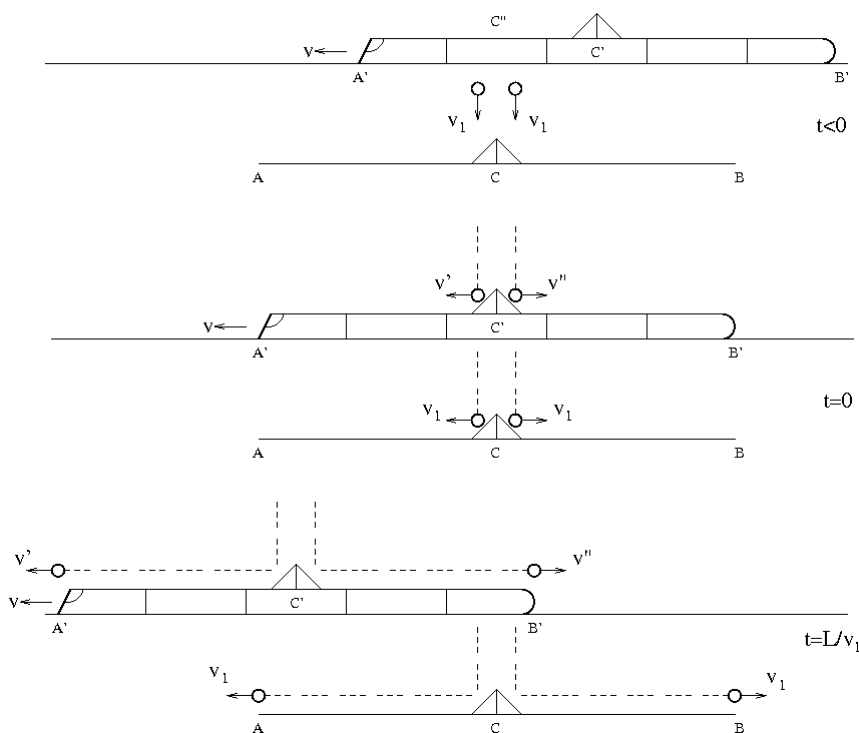

Figure 1.15: The mechanical model for the relativity of simultaneity.

these points  $A', B', A, B$  from  $D$ ) at some finite speed  $v_1$  (in this case SRT and light speed constancy will be without any relevance).

We can suggest the following mechanical model (Fig. 1.15): Let four material points (without the force of gravity) fall at speed  $v_1$  in pairs over point  $C$  (close to the railroad bed) and over the train's centre  $C'$  which will arrive to the point  $C''$  near to point  $C$  at the moment of intercept of falling points. Let ideal reflectors (isosceles triangles with angle at a base  $\alpha = \pi/4$ ) be installed at point  $C$  and at train's center. Then two particles, reflected over the railroad bed (at

point  $C$ ), will fly to different sides at speed  $v_1$ , and simultaneously reach points  $A$  and  $B$  (in the classics  $|AB| = |A'B'|$ ). This process will take time  $t = L/v_1$ , where  $2L$  is the length of the train. Two other particles, reflected over the train's center  $C'$ , will move after reflection (relative to the railroad) at speeds  $v' = v_1 + (v/\tan \alpha) = v_1 + v$  (forwards) and  $v'' = v_1 - v$  (backwards). During the same time  $t$  the first of these particles will traverse the path (forwards)  $L' = v_1 t + vt$ , and, since the train traverses the path  $vt$ , the particle will reach point  $A'$ . Similarly, for the second particle  $L'' = v_1 t - vt$ ; hence, it reaches point  $B'$ . Thus, the event – the falling of the points to the reflectors – will be recorded for all four points simultaneously: both at points  $A$  and  $B$  (over the railroad bed), and at points  $A'$  and  $B'$  (over the train). It was the case when the points, falling over train, participated in its inertial movement. If the second pair of points falls (over the railroad bed) just over motionless point  $C''$ , the triangular reflector at the train (only at it) should have the following angles at the basis: against the train movement -  $\alpha_3 = 0.5 \arctan(v_1/v)$ , and in the direction of the train movement -  $\alpha_4 = \pi/2 - \alpha_3$ . In this case particles will fly in parallel to the train and will reach its ends simultaneously (but not simultaneously with the second pair of particles!). If we want, that all four material points “have flown by” simultaneously over corresponding points  $A', B', A, B$ , angles at the reflector basis (at the train) should be still reduced by angle  $\arccos \frac{v_1}{\sqrt{v^2 + v_1^2}}$  (if to establish a flat waveguide, the pair of particles over the train will “not rise” too highly, and will move in parallel to the train). Apparently, mechanical analogues are possible for the most different situations.

One can say that these two events are quite different. But in the case of the light flash, we have two different events as well. Indeed, let the light flash occur at the time of coincidence for the centers  $O$  and  $O'$  of systems  $S$  and  $S'$  moving relative to each other at a speed  $\mathbf{v}$ . At some time instant  $t > 0$ , the light front will be on the sphere  $\Sigma$  relative to center  $O$  in system  $S$  and on the sphere  $\Sigma'$  with center  $O'$  in system  $S'$  (which seems to be impossible). However, there is nothing surprising (i.e. contradicting classical physics) in this

situation, because the observers in system  $S$  and  $S'$  will record one and the same light to have different frequencies  $\omega$  and  $\omega'$  by virtue of the Doppler effect. But in this case these are two identifiably different events: the observers can always compare the results of measurements  $\omega$  and  $\omega'$  upon meeting!

Consider now in detail the mental experiment allegedly “demonstrating” the relativity of simultaneity: at the origins  $O$  and  $O'$  of reference systems  $S$  and  $S'$  that move relative to each other, a light flash occurs at the time of their coincidence. According to SRT, during the time  $\Delta t = t_1 - t_{01}$  on the clock of system  $S$ , the light will pass the distance  $c(t_1 - t_{01})$  from center  $O$ . For the same time  $\Delta t = t_2 - t_{02}$  on the clock of system  $S'$ , the same light will pass the distance  $c(t_2 - t_{02})$  from center  $O'$ . The time difference  $\Delta t$  is not influenced by any matching of initial times, whether accomplished it before the experiment, or after it by any method. For example, an infinitely remote periodic source located perpendicular to the direction of motion can be used. It is possible to arrange in advance about the flashes, produced according to the clock of system  $S$  (for example, periodically each million years), and, one instant before the pre-selected flash, “to organize” the system  $S'$  (in Section 1.7, the nonlocality paradox connected with this will be considered).

Recall that the basic positive idea of SRT consisted in the finiteness of the speed of interactions. The same idea is expressed by the theory of short range interactions, which reflects the field approach (via the Maxwell equations); namely: a light wavefront moving from a source to a receiver passes sequentially through all intermediate points of space. It is just this property that comes in a conflict with the notion of relativity of simultaneity (Fig. 1.16). To prove this, we will use two following statements from SRT.

- 1) One and the same flash of light simultaneously reaches two observers moving relative to each other, despite the fact that during the passage of light, the observers will be spatially separated from each other by some distance.
- 2) Kinematic formulas of the SRT (from textbooks) contain squares of velocities only.

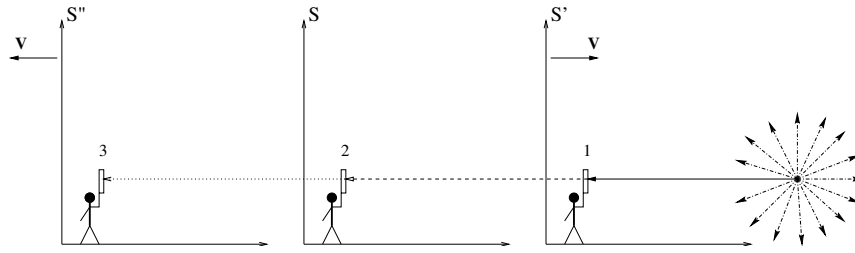

Figure 1.16: The contradictions of the relativity of simultaneity.

For example, let the first observer in system  $S$  be moving towards the flash source at slow speed  $v \sim 10^4$  m/s. Since the distance to the flash point is large (say a million light years), then for one million years both observers will separate from each other to a large distance – about  $2 \cdot 10^{17}$  m. According to SRT formulas, the times of arrival of a signal will be the same for both observers. At what point of space did the first observer lose (did miss) the light wavefront for the second observer? But what if he had held a mirror for the whole million years, and removed it one second before receiving a signal? In the second observer's opinion, the signal was reflected by the first observer somewhere ahead. But in this case what thing was reflected by the first observer, if none of his instruments did still react to a flash? In similar manner, a third observer can fly away from the second one at the same speed, but in the direction from the source. If the second observer held a mirror for a million of years except one last second, would the third one see the light?

On the one hand, since the SRT formulas include the square of velocity only, the second observer will consider the time of signal reception by the first and third observers to be the same. It can be agreed that when observers receive the signal under investigation, each of them will send his signal without delay. If second observer's calculations are correct, then since the problem is symmetric, he must receive the signals from the first and third observers simultaneously. On the other hand, according to Maxwell equations,



the light propagates continuously (sequentially through all space points), and the second observer will receive a signal from the first one simultaneously with the event, when he himself will see the signal under investigation. In second observer's opinion, at this time the light has still not reached the third observer. Thus, the second observer comes to a contradiction with himself: the first calculations by SRT formulas contradict the second calculations by the Maxwell equations. Obviously, the observers will see the flash sequentially, rather than simultaneously, since the spatial path of light is unified (is sequential): the source, the first observer, then the second and, at last, the third observer.

We additionally note that even within the SRT framework the concept of the relativity of simultaneity is highly restricted: it is applicable to two separated events only (there are no intersecting original causes, no intersecting aftereffects, and, generally, we are not interested in any additional facts). In reality, even for these selected points the light cones have intersections, to say nothing of all other points in space and time. In fact, we have continuous chains of causally bound (and unbound) events occurring with multiple intersections through every point of space and time (not every reason, of course, results in a consequence at a speed of light). And all this real (different in scale!) time grid is interdependent for the whole space. Therefore, in the general case we can not change (by choosing the frame of reference) the order of succession of even causally unbound events (in any case, this changing would be reflected and reacted somewhere).

## 1.4 The Lorentz transformations

Let us make some comments concerning the Lorentz transformations. One of the approaches to deriving these transformations uses the light sphere, which is visible in different manner from two moving systems (the flash took place at the time of coincidence of the centers of systems). Or, what is actually the same, this approach uses the concept of interval (displaying the same sphere). The solu-

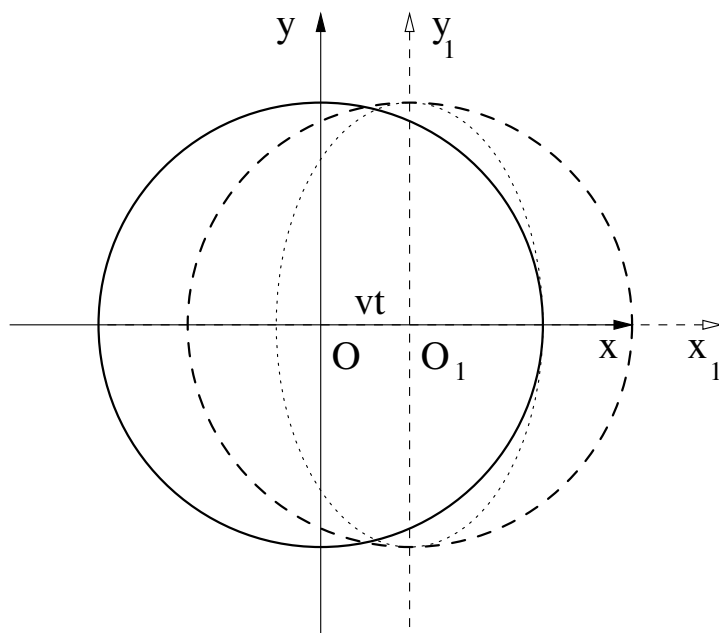

Figure 1.17: The problem of two flashes.

tion of the system of equations

$$x^2 + y^2 + z^2 = c^2 t^2 \quad (1.3)$$

$$x_1^2 + y_1^2 + z_1^2 = c^2 t_1^2 \quad (1.4)$$

represents simply the intersection of two surfaces and nothing more (Fig. 1.17). Under the condition of  $y = y_1, z = z_1$  these figures will be the surfaces of a sphere and of an ellipsoid of rotation with the distance  $vt$  between the centers of the figures. However, this is actually the other problem – the problem on two flashes: it is possible to find the centers of the given flashes for any time instant, i.e. to solve the reverse problem.

In the other approach to deriving the Lorentz transformations such a transformation is sought, which transfers equation (1.3) into

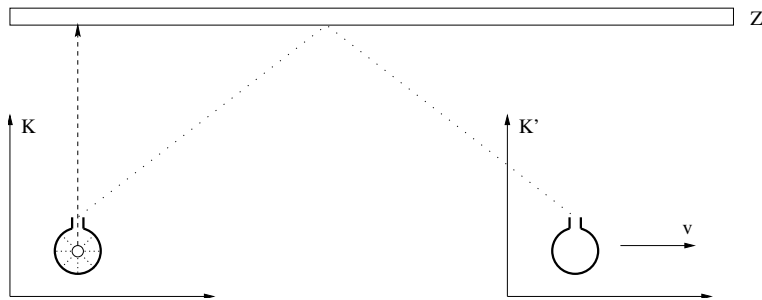

Figure 1.18: The contradiction of a continuum of light spheres.

equation (1.4). Obviously, for four variables such a transformation is not unique. First, the separate equating  $y_1 = y, z_1 = z$  represents only one of possible hypotheses, as well as the requirement of linearity, mutual uniqueness, reversibility, etc. (An additional possibility of frequency-parametrization is described in Appendixes B and C.) Second, any transformation of light surfaces does not determinate the transformation of volumes at all (in which the non-electromagnetic physical processes may occur). For example, the speed of sound does not depend on the motion of a source as well, but no global conclusions follow from this fact.

In any case, the Lorentz transformations in SRT physically describe two objects, rather than a single one. Otherwise it is easy to see a contradiction (Fig. 1.18). Let a light flash occur. Let us separate, instead of a light sphere, one beam perpendicular to the mutual motion of systems  $K$  and  $K'$  (and let the remaining light energy be absorbed inside the system). Let us block the path of the beam by installing the long mirror  $Z$  at a great distance from sphere's center (along the line parallel to the line of mutual motion of systems). Then the observer situated at the system  $K$  will register a reflected signal after some time. Let the signal be completely absorbed. However, the other observer moving together with system  $K'$  will catch a signal, also after some time, at the other point of space (let the signal be absorbed too). If we take a "continuum"

of systems with different mutual velocities  $v$ , then the signal can be caught at any point of the straight line. Then where has the additional energy appeared from? May be, this is SRT's perpetuum mobile of the first kind?

Note that if some mathematical equation is invariant relative the transformations of Lorentz type with some constant  $c'$ , it means only that among particular solutions of this equation there exist "surfaces" of wave type which can propagate with the velocity  $c'$ . However, in this case even the given equation can have other particular solutions with other own invariant transformations, to say nothing of other mathematical equations, i.e. no overall mathematical conclusions do not follow from the fact of invariance. Only relativists try "to blow the big soap-bubble" from one particular phenomenon.

## 1.5 Paradoxes of lengths shortening

Now we proceed to spatial concepts. Since all SRT conclusions follow from the invariance of an interval, then from the above-proved equality  $dt = dt'$  and from the relativistic equality  $c = \text{constant}$  (if we trust in it), we obtain  $dr = dr'$ , and so it is not necessary to further consider the concept of space at all. However, to form the most complete viewpoint, whenever possible in this book, we shall consider each disputable point irrespective of remaining ones.

The contraction of lengths in SRT can not reflect a real physical effect, because various observers can see the same object in different manner (the non-objectiveness). Besides, the transition from one system of reference to another system of reference can proceed rather rapidly. This transition would be reflected in the whole (even infinite) Universe at once, which is obviously contrary to the principle of finite rate of interactions (which is advocated by SRT) and, consequently against the principle of causality. Therefore, similar contractions are nothing more, than supplementary mathematical manipulations with quantities, some of which have no physical sense. The real physical mechanism can not be attracted to explaining the

length contraction process in SRT, since the contraction should take place immediately for any velocity  $v \neq 0$ . In reality, however, it is clear, that in the acceleration process the object can not only be pushed, but also pulled behind yourself, and in such a case, instead of contraction, we would have stretching (experimentally detectable, by the way!). At slow constant acceleration this constant state of stretching would remain the same throughout the motion. Thus, the contraction will never begin.

Since SRT was directly created as a “game with Einstein’s spots of light in an absolutely empty space”, then any pseudo-paradoxes using the electromagnetic field (or currents with contacts, lasers, light rays with mirrors) are easily resolvable, and relativists cunningly present them as allegedly the absence of contradictions in SRT. To do this, they simply make a forgery and, instead of real paradoxes, they “analyse” such pseudo-paradoxes (“added” or “invented” by them) with all sorts of electrical contacts, allegedly spectacular explosions, etc. So, beware of this scam! Now we proceed to some particular paradoxes of shortening of lengths.

### Flights along coordinate axes

It would even be possible to start the book with this key paradox, but the author chose a more habitual path. And the bottom line is that some physicists, after deepening into formalized details, have ceased to feel that any particular physical phenomenon is **only part of a single whole**.

Imagine three rockets with astronauts flying towards the origin  $O$  of a coordinate system (which we will call the resting system). One rocket moved uniformly along the  $X$  axis at a speed of  $0.99c$  for 100 years according to the clock of the resting coordinate system. The second rocket moved uniformly along the  $Y$  axis at a speed of  $0.9999c$  for 1000 years according to the clock at the origin  $O$  of this coordinate system. The third rocket flew uniformly along the  $Z$  axis at a speed of  $0.999999c$  for 1 million years according to the clock at the origin  $O$  of the resting system. And these three rockets

simultaneously fly past the origin  $O$  of coordinates (what happened before this moment of the experiment: how, when and from where these rockets were launched, everyone can calculate according to that theory in which he personally believes). At the time of the passage through the common origin of coordinates  $O$ , all astronauts and the resting observer at this point  $O$  look at the **single Universe surrounding them**, and then exchange radiograms about what they saw **at one and the same time at one and the same point in space**. The resting observer will contemplate the familiar “eternal Universe”. According to SRT, the astronaut of the first rocket will declare that the entire Universe has been compressed along the  $X$  axis by 10 times, the astronaut of the second rocket will state that the entire Universe has been compressed along the  $Y$  axis by 100 times, while the astronaut of the third rocket will to state that **the same Universe** has shrunk along the  $Z$  axis by a factor of 1000. Can anyone really believe in such nonsense: the movement of a rocket has compressed our entire Universe? And this is without any physical mechanism. Reincarnation of Baron Munchausen! Or did not the entire Universe shrink, but only part of it (respectively 100, 1000 and 1000000 light years), so as not to clearly fail the principle of causality? And there was a gap with the rest of the universe? Either option is obviously relativistic nonsense.

Thus, relativistic transformations determine only auxiliary letters, but not real coordinates: in reality, it turns out that  $d\mathbf{r} = d\mathbf{r}'$ . And again, since all SRT conclusions follow from the invariance of the interval, then, if we believe in the relativistic equality  $c = \text{constant}$ , we get  $dt = dt'$ , and it would be possible not to consider the changing the time course. However, to complete the view on the theory of relativity, we will continue to study the full picture of the absurdity imposed by this theory.

### The paradox of a cross

Let a thin plate of large size lie on a solid plane. A small cross is cut out of the plate (Fig. 1.19). Let the length of this cross be much

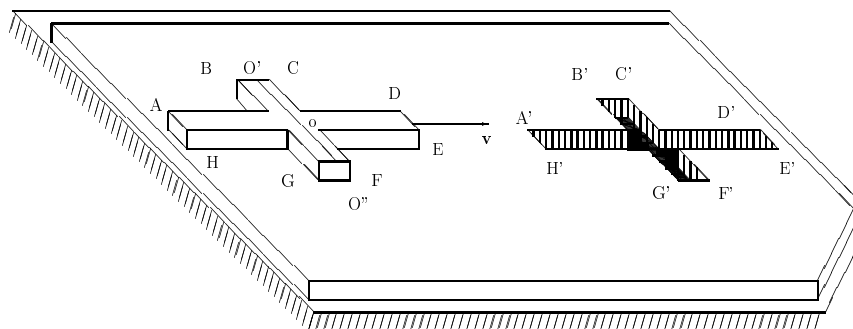

Figure 1.19: The paradox of a cross.

larger than its cross-beam width  $|AD| \gg |BC|$ . Let the cross slide horizontally over the plate, so that in classical physics it would just occupy its niche and fall into it under the effect of gravity. We choose the relative velocity of motion  $\mathbf{v}$  such that, in accord with relativistic formulas, the length to be shortened two-fold (or even more). Note that the center of gravity of the cross (point  $o$ ) lies also at the cross-beam center. Hence, vertical motions of the cross (falling down, or turning over its front end) is possible only if: 1) center  $o$  and the whole central line of a cross-beam ( $O'O''$ ) are over empty space, and 2) none of points  $C, D, E, F$  has support. From the viewpoint of an observer on the cross, he lightly will slide over a two-fold shortened niche to its end, since either the cross-beam and one of ends, or both ends of the cross lean against the plate. The known trick with turning of a rod fails in this case (this problem will be considered below). However, from the viewpoint of an observer on the plate, the cross (which became two-fold shorter) will fall down into the niche. Thus, we have two different events: Does the downfall of the cross (a push against the plane) take place or not? And what will happen to the observer, who falls down into the niche (will he be crushed or not)? Or, in order to be saved, does he urgently need to accelerate to the speed of the cross  $\mathbf{v}$ ? Or should one be near the end of  $A'H'$  (or  $D'E'$ ), where the shortened cross cannot reach? If

someone really wants to reformulate this paradox as a paradox of existence, then, remembering the remark of the previous paragraph about relativistic “electromagnetic forgeries”, the exploder should be under the plate, and the button contact could be closed under the plate in the center of the cruciform niche only by the center of gravity of the cross in case of its possible fall.

### **Additional paradoxes and “strangenesses”**

We describe another paradox. Let the circle be cut off the plate and begin rotating around its center. Due to length shortening, an observer on the plate should see a part of clear space and the objects behind the plate. At the same time, the observer on the circle should see, how the plate runs over the circle. The noninertial character of the system does not matter, since the acceleration  $v^2/R$  even for  $v \rightarrow c$  can be smaller than any prescribed value due to choice of a large value  $R$ . The geometry of a circle will be considered in detail in Chapter 2 devoted to the general relativity theory. Similar contradictions demonstrate logical inconsistency of the habitual relativity theory (predictability – the foundation of science – is lost in this theory).

Note one more “strange thing” (the paradox of distances). Since the shortening of lengths of objects is associated by relativists with properties of space itself, the distance to objects must also be shortened (regardless of whether we approach the object or move away from it!). Therefore, if the velocity of a rocket is high enough ( $v \rightarrow c$ ), we can not only look at distant stars, but also “touch” them, because in our own reference system our own dimensions do not change. Besides, when flying away from the Earth with a large acceleration (the value of acceleration is not limited by SRT) for a long time, we will eventually be at the distance of just “one meter” from it. At which time instant will the observer at this distance in “one meter” see the reverse motion of the spacecraft (contrary to the action of rocket engines)?

The possibility of introducing the absolute time refutes logically



paradoxical SRT conclusions about time slowing, relativity of simultaneity, and, besides, about distances shortening, because now the method of simultaneous measurement of distances does not depend on the motion of objects. Let an thin object (a contour portrait cut out a paper, for example) slide with an arbitrary velocity over the photographic film, for example. If a momentary lighting is made by the infinitely remote flashlight, the length of the shadow photograph as well as the length of the object will be the same. We can use an usual distant source (on a median perpendicular to a plane) in the following case: the flash front will reach the plane at a moment, when the object is flying the median perpendicular (see section 1.7 below - about a “seeming turn” of the wave front).

The reducing of distances to the objects are also contradictory for other reason. Even in motion at pedestrian speed, the distance to far galaxies must be noticeably contracted. However, the direction of such a contraction is indeterminate. If a moving pedestrian casts a look at those galaxies, will he fly away beyond Earth limits? Or, on the contrary, will he (moving) attract another galaxy to himself by his glance? Any of the results is sheer mysticism!

A strange thing, related to length contraction in SRT, occurs with a belt-driven transmission (Fig. 1.20). From the viewpoint of the observers, on each of two free halves of a belt the cylindrical shafts should be transformed into ellipsoidal cylinders and then be turned as follows. The points of semimajor axes of ellipses, which are opposite to each observer, should approach each other (we obtain the non-objective description again). In SRT lengths of upper and lower half of the belt is found to be non-objective, for instance. The contradiction takes place from the viewpoint of the third observer situated on a fixed stand. On one hand, the shafts should approach each other. On the other hand, however, the fixed bearing, which retains the spindles of shafts, should remain at the same place. But what is the thing, on which shafts' spindles will be kept? So, whether the real space is contracted or not? What must be artificially postulated for urgent “saving” SRT: various inserted spaces for shafts and bearing and the change of objective characteristics

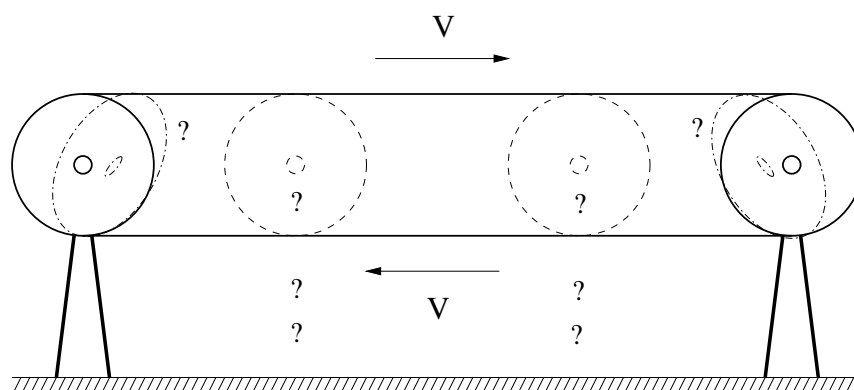

Figure 1.20: Illusions of belt-driven transmission.

(the extensivity) of a belt?

The attempt to hide from explaining the length contraction mechanisms behind the common phrase of type: “this is a kinematic effect of space itself” is unsuccessful because of uncertainty of the “contraction direction” (toward which point of space?). Really, the point of reference (the observer) can be placed at any point of the infinite space – within, to the left or to the right side from an object; and then the object as a whole will not only contract, but also be shifted toward the given arbitrary point. This fact immediately proves the inconsistency or unreality of the given effect. It is not clear, toward which end the segment will contract, if the moving system with two (moving) observers at segment’s ends was made impulsively. The situation can not also be saved by the phrase about the “mutual uniqueness of Lorentz’s transformations”. This condition is quite insufficient. The mutual uniqueness (single-valuedness) of some mathematical transformation allows one to use it for convenience of calculations, but this does not imply in any way, that any mutually unique mathematical transformation has physical sense. Also strange is the process of stopping of contracted bodies. The questions arise: Toward what side do their dimensions



Figure 1.21: Slipping inside the sandwich.

restore? Where has the contraction of space gone, if various remote observers could observe this body?

### Problems on thin rods

Let us consider in detail the problem on 1-meter-long thin rod slipping over a thin plane having a 1-meter-long hole [106] (see [33], exercise 54). It is rather strange, that any object should contract, turn or “deflect and slip down” in exactly the same manner, as it is required to “save” the SRT from contradictions at any cost (however, such an approach is an indirect recognition of principal undetectability of kinematic effects of SRT). What relation to the given problem can have a real rigidity of a rod? No relation! Let the rod be slipping between two planes (a sandwich), so that only a part of a rod freely hanging over a hole be participating in deflection (Fig. 1.21). If the 1-meter-long rod can “deflect and slip down” into the hole shortened down to 10 cm (or 10 times), then in exactly the same manner the 1-kilometer-long rod could also “deflect and slip down” into the hole (but now it should not fall-through neither in the classical physics, nor even in SRT in the system of reference of plane). The declarative mentioning of the velocity of acoustic oscillations (for the balance establishment mechanism) is no more than the “plausible” hiding of the truth. Let there are two identical real horizontal rods at one and the same height (Fig. 1.22). The first rod slips over the desktop (pressing itself against the desktop), and its first tip begins to hang downwards at moment  $t = 0$ . At this instant ( $t = 0$ ) the second rod begins to fall freely downwards. It is obvious that for any time  $t > 0$  the second rod will move down (it failed) to a much greater distance than the end of the first rod will bend (in fact, SRT tries to replace the real body with a body

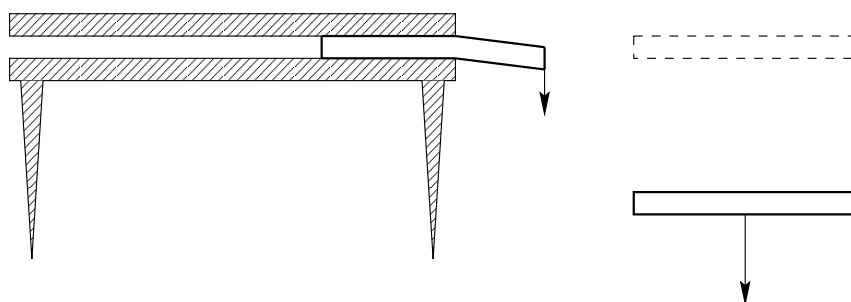

Figure 1.22: Rigidity and the deflection of a rod.

with zero rigidity). For problems under investigation, the relativistic velocities can only decrease the rigidity effect as compared to the case of low velocities, thus a real body will more closely approach to the model of absolutely solid body. Indeed, the rod is deflected in the direction perpendicular to the relativistic motion. Therefore, this problem is similar to the problem on massive body slipping over thin ice on a river: at low velocities the body can fall through (breaching of ice due to its deflection), and at rather high velocities the body can slip over ice without falling through (the ice deflection is small). The rate of acoustic oscillations is much lower, than the speed of light. Therefore, the molecules manage to efficiently participate in rod's deflection for shorter time as compared to the static case; that is, the deflection will be smaller. Let us take the width of the lower plane to be one molecule larger, than the displacement of rod's deflection (for some particular preselected material). At the second end of a hole we shall make a very shallow slope of the plane (Fig. 1.21), so that the given rod could continue slipping over the plane (smoothly). It is obvious that if at non-relativistic speeds, the rod does not slip down into a real 10 cm hole, then even more so at high (relativistic) speeds, the rod will not slide down into a hole (supposedly) shortened to 10 cm. What will happen to the 20-cm or 1-km rod for all former characteristics of the plane? And if we, for the former geometrical characteristics of the experiment, will

take various materials for a rod (from zero to maximum rigidity)? Obviously, with precise fitting of all parameters for one case it is impossible to eliminate the contradictions for all remaining cases. For “saving” SRT it is necessary either to postulate, that the rigidity in the experiment ceases to be an objective property of materials (but ad hoc depends on the observer, geometric size and velocity), or to postulate, that the second end of a hole jumps up ad hoc in the “necessary manner”. Does the goal justify similar means?

A similar problem on passage of a rod, flying along axis  $X$  (now the rod is no longer pressed against the plane) through the niche of the same size (slowly running over the rod along axis  $Z$ ) has even entered the popular literature [6]. The relativists “eliminate” the contradiction in evidences of the observers by an allegedly turn of the rod in space (then the rod will pass through the niche in any case, as in the classical physics). However, the turning does not repeal the Lorentzian contraction. Let us illuminate the niche from below along axis  $Z$  by the parallel beam of rays (for example, from a remote source). Let now rapidly pass the photographic film high above the niche parallel to the plate, but perpendicular to the mutual motion of a rod and a plane, that is, along axis  $Y$  (Fig. 1.23). Then, in spite of rod passage, the result in SRT will all the same be different for different observers. In the classical physics we would obtain the full darkening of the photographic film at the time of rod passage through the niche (this would be marked by a completely dark section on a light strip). A similar full darkening would take place in SRT from the viewpoint of the observer situated on a rod (since the niche will contract and turn). However, from the viewpoint of the observer situated on a plate (and on the photographic film) the rod will contract and turn. Therefore, the full darkening will never take place. In such a case, who is right? Since the relativistic angle of turning of the rod uniquely depends on the ratio of the velocities along the  $X$  axis and along the  $Z$  axis, therefore, the situation can simply be re-made into a paradoxical one. To do this, let another small rod  $l$  slide with a speed  $v_1$  along the first rod (Fig. 1.24, left). Observers at the both rods will claim that the

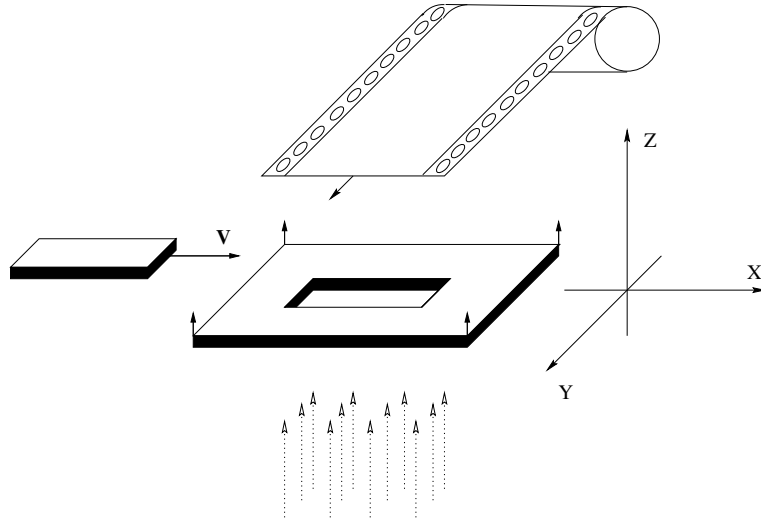

Figure 1.23: "Turning" the rod.

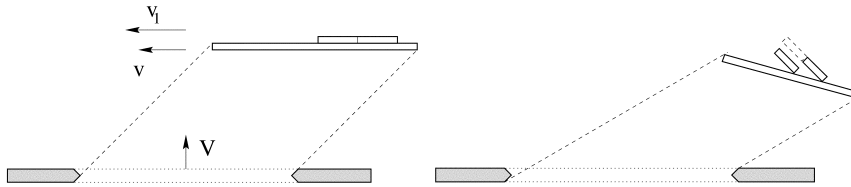

Figure 1.24: The paradox of sliding rods.

clearance between the rods is absent. However, according to SRT, for an observer on the plate, the large rod  $L$  and the small rod  $l$  will be turned through different angles relative to the plate. Due to the difference in speeds  $v$  and  $v_1$ , the small rod will be turned up relative to the large rod, and there will be a gap between the rods. There appears the evident logical contradiction. It can be further strengthened if we apply the method of dividing the whole into parts. Consider first the rod  $l$  as a whole. Then the first half of the rod  $l$  will be raised to a certain height above the rod  $L$ , along which the sliding occurs (see Fig. 1.24, on the right, the half of the rod is a dotted line). Let us now consider another situation, when a small rod is actually divided into two halves. In this case, the situation with the second half of the small rod will be completely similar to the parallel transferring the beginning of the first half of the rod. Consequently, these halves will be the rear ends on a large rod, but spatially separated (Fig. 1.24, right, solid line). This situation is strange in that the zero cut must remain zero in SRT for any rotations and multiplications by the relativistic factor. In fact, we played along a bit with SRT by placing the both halves of the small rod **over** the larger rod. The reason for the contradiction is that in SRT there are no solid bodies at all that are impenetrable to other bodies: the entire “physics” of SRT is “derived” exclusively using flashes of light, and flashes are able to penetrate each other. As a result, in order to agree on the evidence of arbitrary observers (for example, in the center of the rod), it would be necessary to assume that it is in this place that the rods pass through each other (an absurd discrepancy between relativistic manipulations and reality).

### Some remarks on lengths shortening

We will additionally consider now the relativistic effect of contraction of distances (the paradox of pedestrians). We will “agree in advance” about the following mental experiment (Fig. 1.25). Let a beacon, disposed at the middle of a segment, to send a signal toward its ends. Let segment’s length be one million light years. At

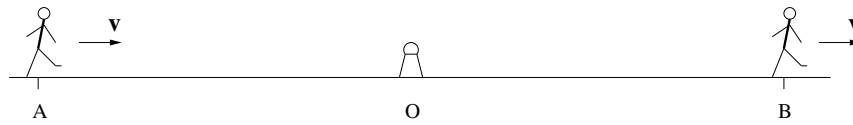

Figure 1.25: The paradox of two pedestrians.

the time of arrival of a flash two pedestrians at segment's ends begin to walk at equal velocity toward the same preselected side, along the straight line containing the given segment, and they will be walking for several seconds (the transient process lasts a fraction of a second and cannot play any significant role in the phenomenon). The moving segment (a system of two pedestrians) should be contracted relative to the ends of a motionless segment by some hundreds kilometers. However, none of pedestrians will “fly away” for hundreds kilometers during these seconds. The moving segment could not also be torn off at the middle, because the Lorentz transformation laws are continuous. So, in such a case, where did this segment shorten? And how this can be detected?

This paradox can be further strengthened, because SRT does not impose fundamental limitations on acceleration. Let one rocket be at a distance of one light-second from alpha Centauri, and the second exactly the same rocket is at a distance of one light-second from the planet Earth. These two mutually resting rockets make up one frame of reference, and the Sun (Earth) - alpha Centauri system makes up the second frame of reference (with sufficient accuracy, we consider all objects to be mutually resting too). The conditions of the experiment are agreed in advance, the time is synchronized. At the given time, both rockets simultaneously accelerate for about one second in the direction of the Earth (slightly past) and reach this speed  $v \approx c$  (the second rocket is right near the Earth), that the distance between the rockets is reduced to one and a half meters (after all, this is supposedly the kinematic effect of space itself!). And the distances for pedestrians on planet Earth have remained the same. Then, at the moment of the passage of the nearest rocket



over the pedestrian's head, he starts towards the distant rocket, passes 2 meters in a second, stops and turns around. According to relativistic fairy tales, he should see the tails of both rockets. Both rockets at this moment begin to slow down and stop in a second. But after all, in three seconds of flight, the rockets could not travel a distance of more than three light seconds. So, at about this distance, the first rocket should be located near alpha Centauri, and the second rocket should be located near the Earth. It turns out that during this second of deceleration, the first rocket should fly tail first (return) to alpha Centauri at a distance of about 4 light years, i.e. at a speed hundreds of millions of times faster than the speed of light! Contrary to their own postulates...

For "justifying" the relativistic contraction of lengths Fock [37] discusses as follows. In the motionless coordinate system the lengths (factually fixed by tips of a segment) can be measured non-simultaneously, but in the moving system they must be measured simultaneously. From the invariance of the interval

$$(x_a - x_b)^2 - c^2(t_a - t_b)^2 = (x'_a - x'_b)^2 - c^2(t'_a - t'_b)^2$$

at the choice of  $t'_a = t'_b$ ,  $t_a \neq t_b$  we obtain  $|x_a - x_b| > |x'_a - x'_b|$ . But in such a case, why we can not choose  $t_a = t_b$  arbitrarily in order to obtain the objective length  $|x_a - x_b|$  in a unique manner? The existence of the process of measuring the length (the tips of a segment), which is independent of time and of the concept of simultaneity for the intrinsic frame of reference, proves a full independence of time and spatial characteristics in this system. But why for the other, moving system must arise any new additional link between the coordinates and time except the kinematic concept of velocity?

Wrong is Mandelshtam's [19] judgement, that there is no "real length", and his example with the angular measure of an object. The angular measure of an object depends not only on object's size, but also on the distance to it, that is, on two parameters. Therefore, this measure can be made unique only if one parameter – the distance to an object – is fixed. Incorrect is also Mandelshtam's statement, that in any method of measuring the lengths, the rods moving in

different manner have different lengths. For example, the procedure of measurement (direct comparison) of the rods previously turned perpendicular to the relative motion of the rods is possible. Then the rods can be turned in arbitrary manner. They could even be slowly rotating in order to occur to be perpendicular to the motion at the time of coincidence. In such a case, this method is completely independent on the relative motion even in SRT.

Some relativists believe that there is no length contraction at all – only the turning exists, for example, for a cube (i.e. they cannot unambiguously agree even between each other). The absence of real turning of a cube (or the fact that this effect is only apparent) can easily be proved, if the cube will fly being pressed against a ceiling. Generally speaking, the distance to objects, their visible velocity and size can be determined, even with the help of the light, by several techniques which are “self-consistent” by themselves. For example, even for a single observer: from the angular size, from illumination, from the Doppler effect. But the obtaining of different values for the same physical quantity does not cancel at all the only true objective characteristics of a body and its motion (under which the instruments are calibrated).

The SRT tries to “purchase” the consistency of its determination of lengths by refusal from the objectivity of some other physical quantities. However, this trick won’t “work” with respect to the time – it is irreversible. Note some strange thing: in the sense of reversibility (in transition from one inertial frame of reference to the other and back!), the linear Lorentz transformation are fully equivalent both for coordinates and for the time (they are reversible). It seems strange, then, that a difference between bodies’ lengths vanishes with return at initial place (for twins, for example), but the disparity remains in the time elapsed.

## 1.6 The relativistic law for velocity addition

Recall that the kinematics does not study the causes of motion, but, for example, knowing the given velocities, it finds the result of

addition of these velocities. The issues of dynamics of particles (i.e. causes of motions) require independent consideration (see Chapter 4).

We begin with a remark concerning the relativistic law for velocity addition. For two systems participating in relative motion, the determination of their relative velocity causes no doubts (neither in classical physics nor in SRT). Let system  $S_2$  be moving relative to system  $S_1$  at speed  $v_{12}$ ; similarly, let system  $S_3$  be moving relative to  $S_1$  at speed  $v_{13}$ . Both of these velocities can be experimentally measured by an observer in the  $S_1$  frame. In fact, the relativistic law for velocity addition defines the relative speed of that motion in which the observer does not participate himself: the speed of motion of system  $S_3$  relative to  $S_2$  is determined as

$$v_{23} = \frac{v_{13} - v_{12}}{1 - \frac{v_{13}v_{12}}{c^2}}. \quad (1.5)$$

It is precisely this form (although usually  $v_{13}$  is expressed in terms of  $v_{12}$  and  $v_{23}$ ), which discloses the real essence of this law: it tells what relative speed of systems  $S_3$  and  $S_2$  will be recorded by the observer in  $S_1$ , if the Einstein rule is used for time synchronization and for measuring length. And to put it bluntly, without diplomatic tricks: the “law” says what relative speed of the systems  $S_3$  and  $S_2$  “directively” should attribute to the “blind” observer in the  $S_1$  system, so that, God forbid, let down the “only true doctrine” of SRT (which uses Einstein’s artificially invented method for time synchronization). Factually, we have here the “law of visibility”. (For the case of possible parametrical frequency dependence of light speed, this expression will change – see Appendixes B and C).

Consider the following methodological remark. One rather strange thing for the kinematic notions from SRT is the non-commutativity of the relativistic law for velocity addition of non-collinear vectors. The non-commutativity property (and the fact, that the Lorentz transformations without rotations do not compose a group) is mentioned only briefly in some theoretical physics textbooks. By contrast, a similar property in quantum mechanics

essentially changes the entire mathematical formalism and physically expresses a simultaneous immeasurability of non-commuting quantities.

It is clearly seen from the general relativistic law of addition of velocities

$$\mathbf{v}_3 = \frac{(\mathbf{v}_1 \mathbf{v}_2) \mathbf{v}_1 / v_1^2 + \mathbf{v}_1 + \sqrt{1 - v_1^2/c^2} (\mathbf{v}_2 - (\mathbf{v}_1 \mathbf{v}_2) \mathbf{v}_1 / v_1^2)}{1 + (\mathbf{v}_1 \mathbf{v}_2)/c^2}. \quad (1.6)$$

that the result depends on the order of transformation. For example, in the case of sequence

$$+v_1 \mathbf{i}, -v_1 \mathbf{i}, +v_2 \mathbf{j}, -v_2 \mathbf{j},$$

where  $\mathbf{i}$ ,  $\mathbf{j}$  are the unit vectors of the Cartesian coordinate system, we obtain a zero sum velocity, and for the other order of the same quantities

$$+v_1 \mathbf{i}, +v_2 \mathbf{j}, -v_1 \mathbf{i}, -v_2 \mathbf{j}$$

we obtain a non-zero sum velocity, which depends on  $v_1$  and  $v_2$  in a rather complicated manner. The successive application of transformations (of motions) of  $v_1 \mathbf{i}$  and  $v_2 \mathbf{j}$  results in

$$\mathbf{v}_3 = v_1 \mathbf{i} + \sqrt{1 - v_1^2/c^2} v_2 \mathbf{j},$$

and in the other order of  $v_2 \mathbf{j}$  and  $v_1 \mathbf{i}$  it results in

$$\mathbf{v}'_3 = v_2 \mathbf{j} + \sqrt{1 - v_2^2/c^2} v_1 \mathbf{i};$$

that is, we obtain different vectors (Fig. 1.26).

In such a case, what can the decomposition of the velocity vector into components mean? First, the transfer of simplest, classical calculation techniques (the commutative algebra) to relativistic (non-commutative) equations is illegal: even the solution of vector equations in a component-by-component manner requires additional postulates, complications or explanations. Second, a simple application of the methods of classical physics (such as the principle

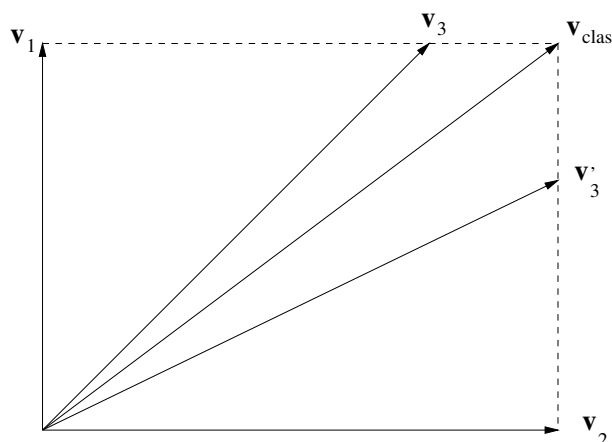

Figure 1.26: Velocity parallelograms in SRT.

of virtual motions, the variation methods, etc.) is impossible. In this case, even a “zero” had to be “individualized”: the number of “zero” quantities, composed of some vector combination, should be equal to the number of “zero” quantities composed of a mirror vector combination. Hence, the theory of fluctuations would also require additional substantiation in such a case. Thus, contrary to the statement “on the simplicity and elegance of SRT”, the correct justification of even simplest procedures would require introducing many artificial complications and explanations (which are absent in the textbooks).

Consider the logical contradiction of the relativistic law of velocity addition for the example of one-dimensional case. Let us have a balance in the form of a horizontal groove with a horizontal transverse pivot at the middle. Two identical balls of mass  $m$  will roll along a groove from the pivot to different sides (Fig. 1.27). To avoid discussing properties of the relativistic mass, we shall proceed as follows. Let the balance pivot be frictionless except when the balance is in the horizontal position (the “dead point”). At this position, the threshold of the friction force does not allow the balance to rotate

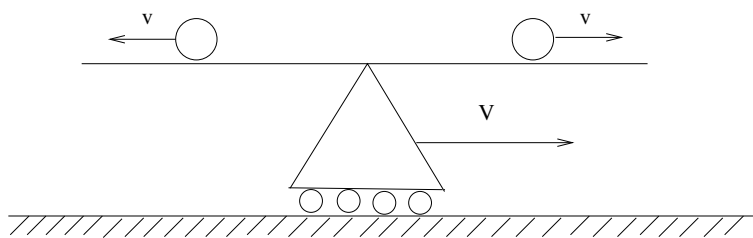

Figure 1.27: The law of addition of velocities and the paradox of a balance.

due to any possible small difference between the relativistic masses of the balls. But this sensitivity threshold cannot prevent the balance to rotate from the “dead point” in the absence of one of balls, when it will fall downwards. Let the velocities of balls in the system be equal in magnitude. Therefore, the balls in this system will simultaneously reach the edges of the groove and fall downwards, so that the balance will be kept at the horizontal position. Consider now the same motion in the system, relative to which the balance are moving at speed  $V$ . Let be  $V \rightarrow c$  only, but  $v \ll v_s$ , where  $v_s$  is the speed of sound for the material of the groove. Therefore, the balance can be considered as absolutely rigid (we can ignore acoustic waves). According to the relativistic law of addition of velocities,

$$v_1 = \frac{V - v}{1 - vV/c^2}, \quad v_2 = \frac{V + v}{1 + vV/c^2}.$$

The motion of a middle point at speed

$$\frac{v_1 + v_2}{2} = V \frac{1 - v^2/c^2}{1 - v^2V^2/c^4} < V$$

always lags behind the motion of the balance. Thus, the ball moving contra to the direction of motion of the balance will fall down first. As a result, the equilibrium will be violated, and the balance will begin to rotate. So, we have a contradiction with the data of the

first observer. Will the observer get hit if he will stands under the right-hand part of the balance?

Will the Lorentz transformation laws be able to describe successive transitions from one inertial system to another, and does the relativistic law of addition of velocities correspond to real velocity variations? Certainly not. At the beginning, we remind the meaning of the relativistic law for velocity addition. It must prove that the addition of any motions cannot lead to a speed greater than light speed. What is the sequence (in the meaning), in which motions must be added to each other in such a case? For example, the Earth flies relative stars (factually, there exists the first moving system of reference), a spacecraft takes off from the Earth with a large velocity (in fact, the second reference system is “created”), then, a subsequent spacecraft takes off from the first spacecraft (factually, the third reference system is “created”), and so on. It is exactly their meaning for consecutive application of transformations. Therefore, the following question no longer arises: In the relativistic law for velocity addition, which of velocities must be considered as the first one, and which velocity is the second one (This is important for non-commutative transformations). All the above examples in this Section had this meaning.

Let us consider now the Lorentz transformation law for arbitrary directions of motion:

$$\mathbf{r}_1 = \mathbf{r} + \frac{1}{V^2} \left( \frac{1}{\sqrt{1 - V^2/c^2}} - 1 \right) (\mathbf{r}\mathbf{V})\mathbf{V} + \frac{\mathbf{V}t}{\sqrt{1 - V^2/c^2}},$$

$$t_1 = \frac{t + (\mathbf{r}\mathbf{V})/c^2}{\sqrt{1 - V^2/c^2}}.$$

It can easily be verified, that the successive application of the relativistic law for velocity addition (1.6) to quantities

$$v_1\mathbf{i}, \quad v_2\mathbf{j}, \quad -v_1\mathbf{i} - v_2\sqrt{1 - v_1^2/c^2}\mathbf{j} \quad (1.7)$$

will give a zero. To an arbitrary vector  $\mathbf{r} = x\mathbf{i} + y\mathbf{j}$  we apply the Lorentz transformation laws successively with the same set of veloc-

ities. Then we have:

$$\mathbf{r}_1 = \frac{x + v_1 t}{\sqrt{1 - v_1^2/c^2}} \mathbf{i} + y \mathbf{j},$$

$$t_1 = \frac{t + xv_1/c^2}{\sqrt{1 - v_1^2/c^2}}.$$

Further, we have:

$$\mathbf{r}_2 = \frac{x + v_1 t}{\sqrt{1 - v_1^2/c^2}} \mathbf{i} + \frac{y\sqrt{1 - v_1^2/c^2} + v_2 t + xv_1 v_2/c^2}{\sqrt{1 - v_1^2/c^2} \sqrt{1 - v_2^2/c^2}} \mathbf{j},$$

$$t_2 = \frac{t + xv_1/c^2 + yv_2\sqrt{1 - v_1^2/c^2}/c^2}{\sqrt{1 - v_1^2/c^2} \sqrt{1 - v_2^2/c^2}}.$$

We shall not write down the expressions for  $r_3$  and  $t_3$  in the explicit form because of their awkwardness. However, using graphical programs, we can be convinced of the following properties:

- 1) In the new system, the initial time is desynchronized at any point of space except the coordinate origin.
- 2) The time intervals have changed:  $dt_3 \neq dt$ ; that is, we got into a new moving system, rather than into the initial resting one. Therefore, in the textbooks, as a minimum, the meaning of the Lorentz transformation laws or of the relativistic law of velocity addition is uncovered rather incorrectly.
- 3) The line segments turn out to be not only of a changed length, but also rotated. We can easily be convinced of this, if we find numerically the angle of rotation, i.e. the difference

$$\alpha = \arctan\left(\frac{y_3[x(1), y(1), t] - y_3[x(0), y(0), t]}{x_3[x(1), y(1), t] - x_3[x(0), y(0), t]}\right) - \arctan\left(\frac{y(1) - y(0)}{x(1) - x(0)}\right).$$

You could try to mathematically discuss these properties in terms of the “pseudo-Euclidean character of the metric” as much as you



like. However, physically the situation is quite simple. These properties prove the non-objective (i.e. only illusory) character of the Lorentz transformations and of the relativistic law for velocity addition, and their disagreement with each other. Indeed, since we were successively passing from some one inertial system to another inertial systems, and the rotation implies the non-inertial character of a system, SRT itself escapes the limits of its own applicability; i.e., it is inconsistent. If this rotation were real, this would imply a non-objective character of the inertial system notion (since the result would depend on the method of transition to the given system) and, as a consequence, the lack of a proper basis itself for existence of SRT.

Let us try to clear up why it is that interpretations from the textbooks result in disagreement between two expressions: between the relativistic law for velocity addition and the Lorentz transformations, in spite of the fact that the first expression is derived from the second expressions. Let us recall this derivation on the example of the one-dimensional mutual motion of the systems  $K$  and  $K'$  (note that only the one-dimensional case is considered in the textbooks). Based on the Lorentz transformations

$$x_1 = \frac{x + Vt}{\sqrt{1 - V^2/c^2}}, \quad t_1 = \frac{t + Vx/c^2}{\sqrt{1 - V^2/c^2}},$$

we divide the differential  $dx_1$  by  $dt_1$  with regard to definitions  $v = dx/dt$  and  $v_1 = dx_1/dt_1$  and obtain:

$$v_1 = \frac{v + V}{1 + vV/c^2}.$$

This indicates the following things:

- 1) The observer is placed at the origin of the system  $K$  and measures the distance  $x$  to the studied body in its own system  $K$ .
- 2) He considers time  $t$  to be universal in his system and determines the velocity of a body in his system  $v = dx/dt$ .
- 3) He measures speed  $-V$  of the system  $K'$  with respect to  $K$  using his own (!) time  $t$ , and considers the relative velocities of systems

to be mutually opposite in direction. This observer cannot measure any other thing: the summary velocity  $v_1$  is a computable quantity. Thus, we come to the interpretation [49] stated earlier: the relativistic law of addition of velocities determines the velocity of that relative motion in which the observer himself does not participate. This effect is not real, but only seeming (when we use some artificial rules of SRT). On the essence of this formula, we cannot simply proceed to the second substitution for determining  $v_2$ , though, formally, any arbitrary number of velocity values can be sequentially substituted into the expression for this relativistic law. In the case of addition of motions along a single straight line, the classical property of commutativity is conserved, and the contradiction is veiled over. But if the velocity vectors are non-collinear, then item 3) turns out to be incorrect, and the contradictoriness and inconsistency of the law for velocity addition and Lorentz transformations are immediately appeared.

But we can apply another approach to the example discussed previously: we shall search for the sequence of three transformations of velocities that retains the initial time in the Lorentz transformation laws invariant. Then it can easily be verified that, instead of (1.7), an only single succession can be taken:

$$v_1\mathbf{i}, \quad v_2\mathbf{j}, \quad -v_1\sqrt{1 - v_2^2/c^2}\mathbf{i} - v_2\mathbf{j}. \quad (1.8)$$

However, firstly, the turning of the segments remains. Second, a new set of velocities does not satisfy, in the given succession, the law of velocity addition, i.e. factually there changes the order of substitution of the velocities  $v_1$  and  $v_2$  in the law of velocity addition (that is inconsistent with the essence of this law). Therefore, the contradictions are not eliminated in this case as well. The Thomas precession is an example of SRT inconsistency also: starting from the sequence of inertial systems (moving rectilinearly and uniformly), the resulting rotation of objects is suddenly obtained (principally noninertial motion). Thus, the passage from the Lorentz transformations (outlined in standard textbooks) of “mathematical space”  $1 + 1$  ( $t + x$ ) to the Lorentz transformations of  $1 + 2$  “space” (or  $1 + 3$ ) leads to

physical contradictions.

Many intuitively clear properties of physical quantities lose their sense in SRT. For example, the relative velocity ceases to be invariant. The particles, flying away along the same straight line at various velocities, form in SRT a complicated “fan of velocities” for a moving system. The isotropic velocity distribution in SRT ceases to be the same for the other moving system. No declared simplification does exist in SRT in reality.

Since SRT focuses on the pairwise exchange of signals (by the type of radar signals) and synchronization, the geometric addition of velocities itself becomes internally contradictory. This is in Newton’s theory, which is essentially a mathematical superstructure over reality, we could mathematically subtract a second constant velocity (of object 1) from a first constant velocity (of object 2) and obtain the constant relative velocity of objects 1 and 2. Now imagine that these objects are moving in not intersecting skew straight lines (remember, for example, how one car is moving on a road, and the second car is moving on a bridge over this road). In order for any of these cars to be able to track the movement of another car with a radar, its own radar must **rotate**, i.e. the measuring device will be in a different – non-inertial frame of reference!

The impossibility of existence of velocities  $v > c$  in no way follows from SRT. And the addition, that this statement relates to the signal transmission rate only, is only artificial addition (because of existence of obvious counterexamples to the extended treatment). However, the notion of signal (information) remains insufficiently determinate even with a similar addition. For example, while receiving a signal from the flare of supernova, are we not sure that the same information “is contained” at the diametrically opposite distance from the supernova (that is, we know about it with the velocity of  $2c$ )? Or this is not information? Therefore, SRT can only deal with the information on a material carrier of electromagnetic nature propagating in vacuum sequentially through all points of space from the signal source to a receiver.

Let us make some comment on “astonishingness” of the relativis-

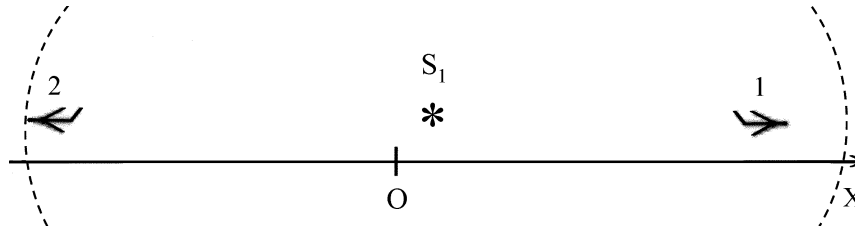

Figure 1.28: Exchange of a signal.

tic law of “addition” of velocities, which allows to exchange light signals even for the algebraic sum of velocities greater than  $c$ . We pay attention to the obvious fact: for exchanging information the signals should be sent necessarily in the direction of an object, rather than in the opposite direction. Therefore, there is nothing surprising in exchanging the signals, where in the classical case it occurs also that, as a result of formal addition of velocities,  $v_1 + v_2 > v_{signal}$ . Let two airplanes take off from the aerodrome  $O$  at velocities of  $0.9v_{sound}$  and fly away from each other in the opposite directions of axis  $X$  (the relative velocity is  $1.8v_{sound}$ ). Whether the exchanging of sound signals between them is possible? Certainly yes! Because the sound wave propagates in air irrespective of the velocity of source  $S_1$  at signal sending time, the first airplane (which has sent a signal) will catch up the wave front propagating in the positive direction of axis  $X$ , whereas the second airplane will “compete” with the wave front propagating in the negative direction of axis  $X$ . Both airplanes are moving slower as compared to propagation of corresponding wave front sections nearest to them (see Fig. 1.28). Thus, the sum of velocities is compared (in a complicated manner), in reality, with quantity  $2v_{sound}$ , rather than with the speed of sound (and for light – with the value of  $2c$ ).

It is obvious also that physical restrictions on the value of speeds cannot be imposed by mathematics (by the allegedly fact that in some expressions there exists a negative value under the radical sign). It should be remembered that all SRT expressions are intro-

duced with use of a light signal exchange (the method of Einstein's synchronization). But if a body moves faster than light long at once, it simply cannot be caught up by signal sent in pursuit. In a similar manner, a synchronization can be made with use of sound (expressions with radicals could be written), but the impossibility of supersonic speeds in no way follows from here at all. The speed of propagation of perturbations (sound or light) in a medium is in no way related to the speed of movement of some body through this medium.

## 1.7 Additional criticism of relativistic kinematics

We shall begin with some general remarks. The group properties of mathematical equations, as the transformations with mathematical symbols, do not bear any relation to any physical principles or postulates; that is, the group properties can be found without additional physical hypotheses. For example, the Lorentz transformations, which reflect the group properties of the Maxwell equations in vacuum (or of the classical wave equation, including that in the acoustics), are not bound at all with SRT's postulate of light speed constancy or with the relativity principle.

The theory of relativity is, in fact, "the theory of visibility": it is about what we see in an experiment, if it is based (with generalization for space and time properties) on the laws of electromagnetic interactions (the absolutisation of electromagnetic phenomena). Similarly, the question can be raised: What will the phenomena observed by means of sound, etc., look like? Certainly, the finiteness of the rate of transmission for some interactions alters the phenomena observed with the help of these interactions. But this circumstance does not prevent making unified extrapolations for "binding" to space and time (which are the absolute physical notions) for the uniform description of the world without limitation by any "overall" hypotheses.

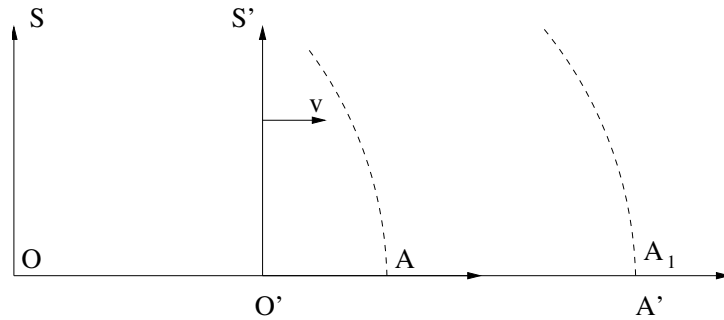

Figure 1.29: The non-locality paradox.

Newtonian space possesses an important property: systems with lower dimensions can possess similar properties. For example, a vector can be introduced not only in three-space, but also on a plane and on a straight line. In SRT, three-dimensional quantities do not possess vector properties (only the 4-vectors do this); that is, there is no continuous limiting transition to classical quantities (the “nearly vector”  $\rightarrow$  vector).

As the next remark, we shall describe the “non-locality” paradox. Note that all SRT formulas do not depend on the previous history of motion, i.e. they are local. Let a system  $S'$  move with velocity  $\mathbf{v}$  relative to a system  $S$ . Let a light flash occur at center  $O$  at the time of its coincidence with center  $O'$ . At time  $t$ , let the wave front reach the point  $A$  in the system  $S$ , and the point  $A'$  in the system  $S'$ , respectively (Fig. 1.29). Now we impart, by impulse, the velocity  $\mathbf{v}$  to a signal receiver in the system  $S$  at a point  $A_1 = A'$ . It happened that the wave front has moved right away to  $A'$  (since we are now in system  $S'$ ). But where had the wave front been at one and the same time instant? Did the time at  $A_1 = A'$  change? And if we will stop the receiver at  $A_1$  after a moment? Whether the time would be restored, and will the wave front again return to  $A$ ? And would the observer forget that he saw a flash of light? Therefore, in order to see the future, must someone move faster? The fact that

the observer at  $A_1$  had not at all times moved together with system  $S'$  explains nothing, since another observer, who had all the time moved together with system  $S'$ , could be at  $A'$ . Does it occur that one of them will see the event, whereas the other one will not? If so, the objective nature of science disappears.

The next additional issue is as follows. Does a wave packet (light) move in vacuum with light speed? If yes, then we cannot break it down into (separate) pulses (signals) by means of a stroboscope: due to length shortening, the length of each pulse and the length of each interval between the pulses must be zero (which is contradictory). If, however, we suppose the dimensions of obtained pulses (signals) and intervals between them to be finite in the resting laboratory system of reference, then in the intrinsic reference system of wavepackage, both pulses and intervals should be infinite (but how can we compare and interrelate in this case the pulse and the interval, where it is absent?). In essence, it is the following question: Whether light and the space between signals possess material nature or not?

Let us make now some comment about a change of the visible direction of particle motion or about a change of the visible direction of wave signal arrival (remember the aberration, for example) as an observer goes to other moving system. This simple classical fact is described in SRT as the turn of all wave front at some angle. As this takes place, the wave front corresponds points of a light sphere at the same time instant. We would remind that the wave front in SRT is different for systems moving relative each other (just as the result of a change in running of time). However, the prehistory of motion of recording instruments is included in none SRT formula. All SRT formulas are local (they do not involve the integral path) and cannot take into account that during the flight of a beam from a distant galaxy, an observer on Earth rotated millions of times around the Earth's axis, around the Sun, and many times around the center of our Milky Way. A photon, flying in space between a source and a receiver, is causally connected in no way with motions of the source and the receiver at the same time instant. The interaction of the

recording instrument with the photon occurs just at the time of signal reception only. No difference exists whether the receiver had been possessing a velocity  $\mathbf{v}$  all the time and was got into this space point at the moment of signal reception, or it had been being motionless at the same space point, but acquired the same velocity  $\mathbf{v}$  at the instant before the signal reception time (the result of interaction with the photon will be the same in both cases). Thus, only the fact of photon arrival to the given place of space matters for the fact of receiving of a signal as such. Obviously, the presence of some velocity of a receiver at the given place of space does not change the **fact** of signal arrival as such (but, according to the Doppler effect, its frequency will be changed only). If the fact itself of the signal receipt was dependent on this, what would the substitution of values into the Doppler formula for the one of systems of observation mean then? Therefore, no real turn of all wave front can be (since it reflects the fact of signal arrival). This is the local (at the given point) mathematical (differential) method to describe the visible direction of signal reception. It can be easily understood by analogy with the usual natural phenomena – with rain and snow (Fig. 1.30). If you look at a cloud over your head in the windless weather when it is raining, you see vertical fall of drops (the direction of “signal” reception). But if you will run (it is better to remember a car travel in a snow day), the direction of drops arrival (the direction of “signal” reception) will far ahead along motion and can be lack of coincidence with the real cloud. However, the horizontal front of rain either already reached the earth surface (the fact of “signal” reception), or not, and this fact does not depend on your motion at the given point of the earth surface at all (see Fig. 1.30).

Consider the following key thought experiment. Let it be at a huge distance (tens or hundreds of light-years) from the terrestrial observer (receiver P), there is a stationary powerful artificial source S emitting light. Suppose two fixed stars are located on two opposite sides of this source on a straight line perpendicular to the source-receiver line at distances of 1 light year (see Fig. 1.31). This source accelerates impulsively for one second in the direction of the first



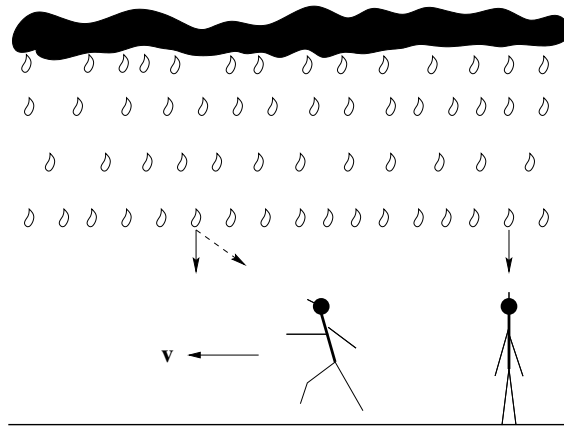

Figure 1.30: The change of the direction of perceiving motion.

star to a speed close to the speed of light (SRT does not impose limitations on acceleration), then flies at this constant speed for one second in the direction of the first star, then slows down impulsively for one second to a complete stop, stands still for one second, after which the source accelerates in the opposite direction, again almost to the speed of light, flies at the same modulo constant speed for one second, slows down for one second and stops at the original starting point. After that, all actions continue in the same order, but already in the direction of the second star: during one second – the source accelerates to a speed close to the speed of light; during one second – flight at the same constant speed; another 1 second – deceleration to a stop, and last 1 second – the source stands still; then, all in the direction of the point start: after second acceleration, the source flies for a second at a high constant speed and stops at the point of the initial start during a second. We are interested in the sections of stops and flights at a constant speed. It is obvious that the segment affected by the flight of our source does not exceed six light seconds in length. Compared to the distance of hundreds of light-years from the source, this is such a small value that the accuracy

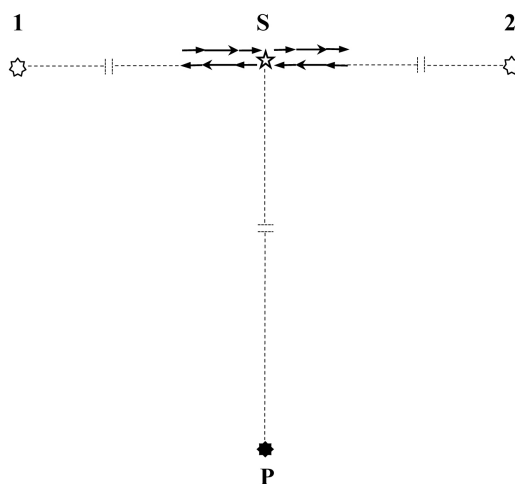

Figure 1.31: Relativistic fantasies about aberration.

of modern terrestrial telescopes will simply not be enough to detect such an angular shift. And what should be from the viewpoint of the theory of relativity? After all, relativists believe that only the relative velocity is included in the formulas. In this case, the angle of aberration when moving at a speed close to the speed of light would be close to 45 degrees. We would not just see from Earth the huge luminous paths of that source, but the source would pierce through both stars, and indeed all the stars in a straight line of its flight up to distances of several hundred light-years there and back! Don't you find relativistic nonsense funny?! Thus, it is obvious that the aberration formula includes only the local absolute speed of the receiver at the point of signal reception (and at the time of this signal reception).

Let us discuss some speculative constructions of SRT. So, unreal in SRT is the consideration of infinite systems, such as a conductor with current, in "explaining" the appearance of additional volume charge (the game with infinities). In reality, the conductor can be close-loop (finite) only. In this case the explanation is not only

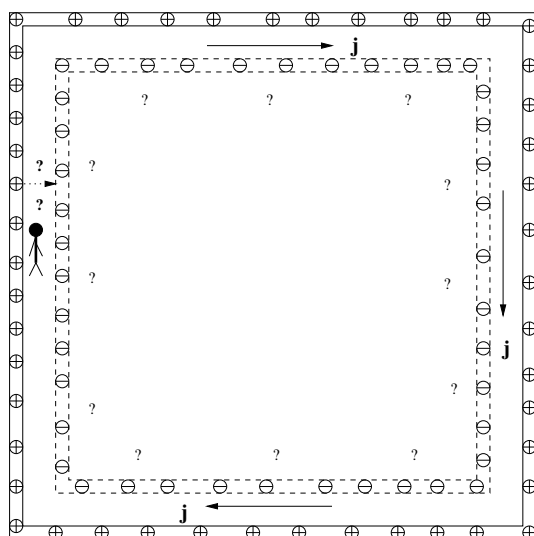

Figure 1.32: The paradox of loop with current.

complicated methodically, but also contradictory. Let us consider a square loop with current (for example, a superconducting loop). The value of a charge of each electron and ion is invariant; the total number of particles is invariable too. How can change the density of charges in this case? Consider the motion of electrons from the viewpoint of a “system of ionic grid” (Fig. 1.32). According to SRT, the “electronic loop” should decrease in size (the contraction of lengths because of motion of electrons on each rectilinear section). It would seem that, owing to symmetry of the problem, the “electronic loop” should enter inside the “ionic loop”. However, in such a case we would have a strange asymmetrical field (of dipole type) near the conductor. Besides, while moving at high velocity, the electrons and ions could appear on different sides from the observer. It is completely unclear, how such a transition through the observer (perpendicular to the motion of particles!) could take place at all? And by what forces the charged electrons (as well as the ions) would be re-

tained together in a flux, not flying away to different sides? Even if we take advantage of the fitting SRT uncertainty (towards what end does the contraction occur?) for one side of a square, all questions still remain for its other sides.

Let there exist three identical systems at rest, in each equidistant point of which three watches belonging to these three different systems are synchronized. And let the two systems get the velocities, which are equal in modulus and have opposite directions relative to the third immovable system. The question is, how will the readings of all three watches correlate at each meeting point? After all, symmetry with respect to the third system guarantees one and the same watch readings of the first and second systems, despite their mutual movement.

The SRT's system of watches and rulers is inconvenient both theoretically and practically, since it supposes that all the data are gathered and analyzed (interpreted!) somewhat later. The unambiguity of interrelation between the classical Newtonian and relativistic Lorentzian coordinates does not imply automatic consistency of latter ones (the distinction of physics from mathematics consists just in this, physical sense). For example, in aerodynamic studies, we could use in all formulas the speed of sound in air instead of speed of light and consider the motions on the Earth at subsonic velocities in resting air. However, the inconsistency of similar transformations of SRT type (for the time) would be immediately revealed in the experiment. This fact demonstrates the hazard of formally mathematical analogies for physics.

It is obvious that the relativistic hypothesis for time dilation is wrong, since only the square of relative velocity is included in the formula (the effect does not depend on the velocity direction). Take 4 identical objects. Let second object be moving at some velocity  $\mathbf{v}_{12}$  relative to the first one, then its time will be slowed down relative to the time of the first object. Are you saying that this is an objective effect? (We would remind the meaning of the word "objective": an effect does not depend on presence and properties of the observer which not interacts with the object under study.)

We even would not fly to check it. Let the third object be moving relative to the second one in an arbitrary direction with an arbitrary velocity  $\mathbf{v}_{23}$ . Then, by analogy, its time will be slowed down relative to the time of the second object. Is this effect objective again? Let the fourth object be motionlessly placed near the first object. We even does not try to debate with which velocity the fourth object moves relative to the third object: it is important only that in the general case this velocity does not zero. Therefore, again we have “objective relativistic” time dilatation of the fourth object relative to the third one. Thus,  $dt_1 > dt_2 > dt_3 > dt_4$ . But  $dt_1 = dt_4$ . But  $dt_1 = dt_4$ , since the fourth object and the first object are mutually at rest! Such an absurdity was obtained as the result of a fanatic relativistic faith in the uniqueness and infallibility of Einstein’s method of synchronization in pairs. Objectiveness melt away from under the feet, and a remainder is either the relativistic seeming effect or purely calculated combinations (“floating time zones”). Where is the claimed greatness? Further, for moving systems, for some unknown reason, a contraction of **space itself** must be observed – the so-called kinematic effect. How is it possible to determine the **speed of this very empty space** relative to one or another moving observer in order to calculate such a contraction? Is there a patented device that determines the speed of emptiness? This must be a brilliant invention! It should, probably, be in high demand among road police – there will simply be a gold “milking machine”!

Now we shall make some general remarks. The whole SRT kinematics follows from the invariance of the interval  $dr^2 - c^2 dt^2 = inv$ . However, we see that this expression is written for the empty space. In a medium, the speed of light is non-constant and can be anisotropic; also the light can propagate in the given particular medium for not all frequencies (remind the attenuation, absorption, reflection, dissipation). There is no sections of physics, where the properties of phenomena in vacuum would be automatically transferred to the phenomena in other media (for example, in liquids – hydrodynamic and other properties; in solid bodies – elastic, electri-

cal and other properties). That is, they are not determined by the properties of the empty space. And only SRT pretends to a similar universal “cloning” of properties.

Generally speaking, the properties of light, which are intrinsically contradictory and mutually exclusive, are simply postulated in SRT. Therefore, wrong is Fock’s [37] statement, that the light is a simpler phenomenon, than the ruler. It is not worth to extol the role of light signals and all “visible things”; otherwise a teaspoon inside a glass with water could be considered as the broken one (pure geometrically, the fallacy in this consideration can easily be tested by the direct location of coordinates of all “teaspoon outlets” at the boundary of the liquid). The classical time (or the time determined by an infinitely remote source at the median perpendicular to the line of motion) possesses some important advantage: we know a priori that it is identical everywhere, and no calculations or discussions are required concerning the prehistory of the process or properties of the space. Actually, SRT uses the speed of light as one of measurement standards. Remind that in the classical kinematics there are two measurement standards: the length and time (we will “formulate” evident “laws of constancy of standards”: the length of the standard of 1 m is constant and is equal to one meter, the duration of the standard of 1 sec is constant and is equal to one second, but relativists din “the Great Law of Constancy of the relativistic standard” into everyone’s ears). Since the introduction of a standard is the definition, its properties are not subject to discussion [19]. As a result, everything, which is related with the light propagation, ceases to be a prerogative of experiment in SRT. And because all derivations in SRT are written only for the events – the light flashes, then SRT occurs to be logically inconsistent (to say nothing of the fact, that the “use” of properties of light in vacuum is profusely spread to all other “non-vacuum” phenomena).

Feynman in his book [35] says with sarcasm about the philosophers and about the dependence of results on the frame of reference, but he does not emphasize that, in spite of any “appareness”, the subjects have real objective characteristics. For example, someone

may see that a man seemingly have a size of ant from the great distance, but this does not mean that he has really reduced (all instruments are used to be calibrated just under objective characteristics). The reasoning on a relativity of all quantities seems to be realistic, but (!) once the time in SRT became relative and the rate of interaction was supposed to be finite, the notion of relative quantity for spatially separated objects has become indefinite (it depends on the path of connection, is not bound causally, depends on the system of observation, etc). The definition of all quantities with respect to “far stars” is senseless, since we can see a “never existing reality”. For example, the Alpha-Centaur has been at this particular place and possessed such properties 4 years ago; the other stars have been the same as we see tens or hundreds years ago and the distant Galaxies – billions years ago, i.e. the signal was sent when the earth observer did not exist yet, and is accepted when, possibly, the source itself no longer exists. In such a case, relative to which should we determine the quantities? It is clear that the relative quantities can be determined only with respect to the local characteristics of space (the unique instantaneous causal bond).

In general, what SRT does in kinematics is called “obtaining of images with the help of flashes of light”. It is known that images can be enlarged, reduced, imaginary, distorted (in a distorted mirror), but in no section of physics, except for SRT, on the basis of such images, a conclusion is made about a change in the properties of the objects themselves, on the contrary, a graduating method is sought to extract the **real** information. All loud “spatio-temporal” effects of SRT and GRT are fiction.

Some important remark concerns the notion of relativity, which has even entered the name of the SRT theory. Contrary to Galileo’s ideas on isolated systems, an interchange of light signals between systems is used in SRT. The notion of relativity has been worked up to nonsense in SRT and lost its physical sense: in fact, the system with several (as a rule, two) objects is singled out, and the whole remaining real Universe is eliminated. If even such an abstraction can even be postulated in SRT, then, the more so as, one can simply

postulate the independence of processes inside the separated system on the velocity of system motion relative to the “emptiness” which remained from the whole Universe. But, even in spite of such an abstraction, no “real” relative quantities will appear for bodies (such as  $\mathbf{r}_{ij}$ ,  $\mathbf{v}_{ij}$ , etc.). Indeed, the response of body  $i$  to the attempt of changing its state is determined by the local characteristics: the state of a body  $i$  and the state of the fields at the given point of space. But the changes having occurred with body  $i$  will have an effect on the other bodies  $j$  only in some time intervals  $\Delta t_j$ . Thus, all changes of quantities should be determined relative to the local place (or local characteristics). And these phenomena just represent manifestations of the Newtonian absolute space. The question, whether the separated (preferred) direction and separated (preferred) coordinate origin (either moving or resting) exist in this absolute space – is quite different question. In the abstract (model) theories this question can be postulated, for example, from the considerations of convenience of the theory; but for our unique real Universe it should be solved experimentally. The absolute time notion in the classical Newtonian physics was extremely clear as well. The time should be uniform and independent of any phenomena observed in a system. Exactly such a property is inherent in the time synchronized by an infinitely remote periodic source on a median perpendicular. If your time turned out to be dependent on the process, then you just chose the wrong standard. However, in SRT the time is not an independent quantity: it is associated with the state of motion of a system  $v$  and with the coordinates, for example, by the relation  $c^2t^2 - r^2 = \text{constant}$ . For uniform running of time the choice of the time reference point is arbitrary. For unified description of the phenomena and for comparability of the results the scales (units of measurement) should be identical for all systems. The time running uniformity automatically ensures the greatest simplicity of description of the phenomena and allows to introduce the definition for the basis notion of time with the help of standard.

In any equation of motion, the letter  $t$  is not time itself (not its physical measurement), but just a parameter relating **the length**



**of the path traveled by a particular object** (light, man, turtle) **with its coordinate in a fixed coordinate system** (i.e. Lorenz's view of the new inputed "coordinates" as auxiliary parameters is correct!).

In their agitation for the theory of relativity, the relativists commit the following **two deliberate forgeries**. First, they deliberately try to create the illusion that time and hours are the same thing. Long before the SRT inventions, when the adjusted watches from Europe got to the Equator, it turned out that they began to lag far behind, and these were not mythical nanoseconds, but values that were noticeable almost in a day. Thank God it didn't occur to any idiot, if there was one then, that time on the Equator runs "so dramatically different". Natural scientists immediately identified a specific physical mechanism that affects a particular watch device. Clock accuracy, high or low, also has nothing to do with the passage of time itself! Secondly, relativists deliberately try to create the opinion that time synchronization and signal exchange in the process of experience are one and the same. So, with the introduction of the Gregorian calendar, time was synchronized. But at the same time, no one invented a time machine, did not fly to tell Alexander the Great in what year before the birth of Christ he was born, etc. Simply, if a certain "physical concept" claims to be "scientific", then there are always mathematical formulas and methods of recalculation. And synchronization can be carried out either before, or during, or after the experiment, or, in general, by the method of recalculation. So, for two objects between classical and relativistic quantities there is a one-to-one mathematical relationship (recalculation is possible). This fact was noticed by A. Poincaré and he considered the new concepts and transformations as just one of the possible conventions, along with the previous ones (see [24], "Last Thoughts", Chapter II and Comments at the end books - an article by M. I. Panov, A. A. Tyapkin and A. S. Shibanov). However, new relativistic concepts often fail when describing spatial motions not along one straight line and when the number of objects is more than two.

Let us make some more methodical comments. Generally speaking, in SRT the method of comparison of the phenomena in two various inertial systems supposes, that both these systems have existed for infinitely long time. However, systems are always “attached” to specific bodies and exist only for a finite time. Then, in each particular case the question needs to be studied: Whether the prehistory of formation of these systems (its influence) has been “erased” or not?

The Euclidean analogies with projections in the book [33] are completely inadequate to the reality. The projection is only an abstract method of description, the subject itself does not change at turning. In SRT, on the contrary, the characteristics of an (even remote!) object instantaneously change with changing the motion of an observer in the absence of any mechanism.

Contrary to the artificially supported opinion, there is no limit transition from relativistic mechanics to classical mechanics (for some quantities there is not even an approximate transition!). So, the limiting transition from the Lorentz transformations to the Galileo transformations (for the time  $t = t' + vx'/c^2$ ) indicates that the Newtonian mechanics is not simply a limit of low velocities  $\beta = v/c \ll 1$ , but the other condition is required, namely:  $c \rightarrow \infty$ . But in this case, for many quantities in SRT, there is no limiting transitions to classical quantities (see below, or [50]). However, in the classical physics  $c \neq \infty$ : its finite value was measured even in 17th century! Someone will think that this is an imperceptible correction and will be completely wrong: for example, taking into account the movement of the Earth, the error in the study of Pluto can reach  $30 \cdot 50 \cdot 150000000/300000^2 = 2.5$  sec; and at a distance of a parsec, you get 10,000 seconds – not nanoscale at all.

The property of maximum homogeneity of the space-time can be an attribute of either ideal Newtonian mathematical space and time (being actually a “superstructure from above”), or of the model space (for example, with remotely non-interacting material points). The attempt to rest upon the mentioned property in SRT as on the principal property of the real space and time is artificial. First,

even in the earth scales we can not arbitrarily change the points of space, time instants, directions of axes and velocities of inertial systems (recall the limited nature of the Earth space, the rotation of the Earth, the gravitational field, the effect of the Moon, the electric, magnetic, temperature fields and so on). We have listed above the real achieved practical limitations, rather than the principal restrictions somewhere at relativistic velocities and huge scales of the Universe. True, in the scales of the Universe with its real objects and gravitational fields this property is not confirmed too: the model of uniform “jelly” does not describe the real Universe. Second, in addition to the form of equations, the solution is still determined mathematically by the boundary and initial conditions. This also actually, on real finite scales, prevents any shifts and changes (or it is necessary to change, in addition, the imposed conditions). How can we approach the existing nonlinear properties and equations with the RT claims? Even the “relativity” notion itself does not allow us to make generalization (more likely, the narrowing down) for the real space with gravity. (As Fock [37] has emphasized, the “general relativity theory” term is inadequate).

Theoretically, the principle of relativity (in any known form) supposes that “without looking” outside the limits of a system, it is impossible to discover its uniform motion. Earlier, the ether used to play the role of the all-penetrating medium for possible discovering such a motion. Note that the question was not about the discovery of the absolute motion, but only about the motion relative to ether. That is, it would be possible to compare these motions “without looking outside” the system (here we mean the computational ability only, since the system of registration points and standards cannot be tied with the ether). But even with “canceling” the ether, according to the modern concepts, the “candidate” with similar properties still remains – it is the gravitational field (which cannot be shielded in principle). For example, from the relic radiation anisotropy, under the additional hypothesis on the equality of the rate of propagation of gravitational interactions and speed of light, the anisotropy of the (all-penetrating) gravitational field can follow. Thus, the non-equal

rights of inertial systems in macroscales can be found at the local point, in principle, even “without looking” outside. This can be avoided theoretically under the hypothesis, that the rate of propagation of gravitational interactions is much higher than the speed of light; in such a case the isotropy could be set up, but in actual practice – it is the prerogative of the experiment.

Let us make one more auxiliary remark (observation). How many different versions of the theory of relativity are there? If you listen or read what the defenders of relativism propagate, then you can conclude that there are several completely different theories that are incompatible with each other (that relativists prefer not to notice and not argue with each other – here they have mutual responsibility with “interest” ). The number of theories depends on the following alternative choices:

- the speed of light does not depend only on the speed of the signal source or does not also depend on the speed of the receiver;
- the mass depends on the speed of movement, or “mass is mass”, and it does not depend on the speed of movement;
- relativistic kinematic effects are objective and observable or not observable;
- some relativists categorically state that SRT cannot be used in the presence of any gravity or any non-inertiality, others realize that without the possibility of approximate calculations any theory is dead;
- the speed of light is constant or depends on gravity (sometimes time);
- there are basically no conservation laws in GR, or you can get a field version;
- to determine the change in lengths and the course of time, direct Lorentz transformations must be used, or for these purposes, inverse Lorentz transformations can be used, etc. etc..

Obviously, the number of versions of the theory of relativity is  $2^N$ , where N is the number of different alternatives. So which of the vast array of  $2^N$  options are relativists fighting for as another “the only true doctrine”? For example, on the last point (use direct or inverse

Lorentz transformations, i.e. the observer will be in a stationary or moving system), there are all four options in textbooks, that is called by O.E. Akimov “paradox of a hatch”. In this example, relativists sincerely do not understand the elementary difference: for an objectively existing world, it is not at all one and the same – “you lengthened, or your twin shortened”. To paraphrase a well-known anecdote about Napoleon and his long marshal, it is not at all the same thing “Napoleon rises on tiptoe for a book, or to shorten the marshal by a whole head for his careless word”. And in such a “Procrustean bed”, depriving the head, the theory of relativity is trying to put modern physics.

## 1.8 Conclusions to Chapter 1

The given Chapter1 is basically devoted to general physical issues and to the systematic criticism of the relativistic kinematics. In so doing, a lot of logical and methodical contradictions of SRT is analyzed in detail. If only methodical inaccuracy were included in this theory, it could be corrected, some additional explanations, revisions, additions, etc., could be introduced. However, the presence of logical contradictions brings “to nothing” any results of any theory, and SRT is not an exception in this respect (although rather undemanding attitude to SRT as compared with any other theory is evidenced in science).

We will briefly summarize all of the preceding. In present Chapter such fundamental notions as “space”, “time” and “relativity of simultaneity” were analyzed in detail. The logical inconsistency of the fundamental notion of “time” in SRT was demonstrated on the basis of the following contradictions: the modified twins paradox, the paradox of n twins, the paradox of antipodes, the paradox of time etc. Then, the possibility of introducing a single absolute time independent of the velocity of motion was demonstrated by means of a periodic, infinitely remote source situated across the plane (perpendicular to the line) of motion.

Further, for numerous examples the inconsistency of the rela-

tivistic concept of length was demonstrated. (These examples include: the motion of a cross and a sawn ruler, rotation of a circle, lengths shortening, the belt-driven transmission, the indefiniteness of the direction of contraction, a loop with current, etc.). The SRT contradictions for the problems of rod slipping over a plane and of flying rod turning, the non-locality paradox, limiting transition to classics, and so on, were considered in detail.

In Chapter 1 the true sense of the Lorentz transformations and of the interval invariance was discussed. The contradiction between the “relativity of simultaneity” and the field approach, founded upon the finiteness of the rate of interactions, was considered in detail. The contradictions between the Lorentz transformations and the relativistic law of velocity addition were also discussed in detail. Besides, in Chapter 1 the hyperbolization property of the “relative quantity” concept itself and the space-time homogeneity properties were critically discussed in detail.

The ultimate conclusion of the Chapter consists in the necessity of returning to classical notions of space and time, to the linear law of velocity addition, and classical meaning for all derivative values. The questions of experimental verification of SRT kinematics and questions concerning the relativistic dynamics will be considered in detail in Chapters 3 and 4 respectively. The questions of kinematics of noninertial systems will be touched in the next Chapter 2.

## Chapter 2

# The basis of the general relativity theory

### 2.1 Introduction

The logical inconsistency of kinematics of the special relativity theory (SRT) was proved in previous Chapter 1. This forces to return to the classical notions of space and time. Since relativists declare that SRT is the limiting case of the general relativity theory (GRT) in the absence of gravitation, then there arise some doubts in validity of GRT kinematics also. Unlike SRT, the GRT contains some rather interesting ideas, such as the principle of equivalence expressed via the idea of “geometrization”. (Note that incorrectness of geometrization of electromagnetic fields is obvious: experiments show that neutral particles do not respond to the “electromagnetic curvature of space”.) If it’s basis were true, the GRT could have a claim on status of a scientific hypothesis about some correction to the static Newton’s law of gravitation. Since it is not the case, the gravitation theory must be constructed in a different manner. For some reason, the big bang hypothesis with relativistic cosmology associated with GRT, studies of the so-called dark matter and dark energy are traditionally ascribed to advanced science. A huge number of articles [41,178,181,182,185-187,194,195,198-200], books, con-

ferences, broadcasts and films, are devoted to these studies. For the sake of justice it could be mentioned that GRT, in contrast to SRT, never was the universally recognized non-alternative theory. The current of true criticism of this theory has been continuing from its origin [18,141,157,160,165,166,176,180,183,184,188-193,202]. There exist several rather advanced alternative theories (for example, [11, 18, 157] etc.). Although we shall not analyze theories other than GRT, it must be emphasized that theories, “playing” around change of space and time properties and having relativistic kinematics of SRT as its limiting case, are obviously doubtful.

The basic purpose of present Chapter 2 is the criticism of basis notions of GRT. A logical inconsistency of space and time notions in GRT is demonstrated here. The (plausibly hidden) errors and disputable points from the textbooks [3,17,39] are displayed step by step in Chapter 2. In addition to conventional GRT interpretations, we shall also consider some “relativistic alternative” to cover possible loop-holes for salvation of this theory. The time synchronization issues and the Mach principle are also discussed, and the attention is given to doubtful corollaries from GRT.

## 2.2 Criticism of the basis of the general relativity theory

Many GRT inconsistencies are well-known:

- 1) the principle of correspondence is violated (the limiting transition to the case without gravitation cannot exist without introducing the artificial external conditions);
- 2) the conservation laws are absent;
- 3) the relativity of accelerations contradicts the experimental facts (rotating liquids under space conditions have the shape of ellipsoids, whereas non-rotating ones – the spherical shape);
- 4) there exist singular solutions.

(Usually, any theory is considered to be inapplicable in similar cases, but GRT for saving its “universal character” begins to construct



fantastic pictures, such as black holes, Big Bang, etc.).

### General remarks

Let us consider the general claims to the GRT. We begin with the myth “on the necessity of the covariance”. Along with the form of the equation, the unambiguous solution of any differential equation is determined also by specification of the initial and/or boundary conditions. If they are not specified, then, in the general case, the covariant property either does not determine anything, or, at changing the character of the solution, can even result in a physical nonsense. If, however, the initial and/or boundary conditions are specified, then with substitution of the solutions we obtain the identities, which will remain to be identities in any case for any correct transformations. Besides, for any solution it is possible to invent the equations, which will be invariant with respect to some specified transformation, if we properly interchange the initial and/or boundary conditions.

The analogies with subspaces are often used in the GRT; for example, a rolled flat sheet is considered. However, the subspace cannot be considered separately from the space as a whole. For example, in rolling a sheet into a cylinder, the researcher usually switches, for convenience, to the cylindrical coordinate system. However, this mathematical manipulation does not influence the real three-dimensional space and the real shortest distance in it at all.

The simplicity of postulates and their minimum quantity do not yet guarantee the correctness of the solution: even the proof of equivalence of GRT solutions is a difficult problem. The number of prerequisites should be, on one hand, sufficient for obtaining a correct unambiguous solution, and, on the other hand, it should provide wide possibilities for choosing mathematical methods of solution and comparison (the mathematics possesses its own laws). The GRT, along with artificial complication of mathematical procedures, has introduced, in fact, the additional number of “hidden fitting parameters” (from metrical tensor components). Since the

real field and metrics are unknown in GRT and are subject to determination, the result is simply fitted to necessary one with using a small amount of really various experimental data (first we peeped into the “answer”, and then, with “a smart look”, we will believe that it must be in the theory in just the same manner).

Whereas in SRT though an attempt was made to confirm the constancy of light speed experimentally and to prove the equality of intervals theoretically, in GRT even such attempts have not been undertaken. Since in GRT the integral  $\int_a^b dl$  is not meaningful in the general case, since the result can depend on the path of integration, all integral quantities and integral-involving derivations can have no sense.

A lot of questions cause us to doubt as to validity of GRT. If the general covariance of equations is indispensable and unambiguous, then what could be the limiting transition to classical equations, which are not generally covariant? What is the sense of gravitation waves, if the notion of energy and its density is not defined in GRT? Similarly (in the absence of the notion of energy), what is meant in this case by the group velocity of light and by the finiteness of a signal transmission rate?

The extent of the generality of conservation laws does not depend on the method of their derivation (either by means of transformations from the physical laws or from symmetries of the theory). The obtaining of integral quantities and the use of integration over the surface can lead to different results in the case of motion of the surface (for example, the result can depend on the order of limiting transitions). The absence in GRT of the laws of conservation of energy, momentum, angular momentum and center of masses, which have been confirmed by numerous experiments and have “worked” for centuries, cause serious doubts in GRT (following the principle of continuity and succession of science development). The GRT, however, has not yet built up a reputation for itself in anything till now, except for globalist claims on a fundamentally experimentally unverifiable theory of the evolution of the Universe and several very dubious fittings to a meager experimental base. The following

fact causes even more doubt in GRT: for one and the same system (and only of “insular” type) some similarity of the notion of energy can sometimes be introduced with using Killing’s vector. However, only linear coordinates should be used in this case, but not polar ones, for example. The auxiliary mathematical means cannot influence, of course, the essence of one and the same physical quantity. And, finally, the non-localizability of energy and the possibility of its “spontaneous” non-conservation even in the Universe scales (this is a barefaced “perpetuum mobile”) cause us to refuse from GRT completely and either to revise the conception “from zero”, or to use some other developing approaches. Now we shall pass from general comments to more specific issues.

### The geometry of space

The question on the possibility of changing the real space geometry in GRT is fully incorrect. The finiteness of the transmission rate of interactions can change only physical, but not mathematical laws. Whether shall we assert, that the straight line does not exist, only because its drawing into infinity, even at light speed, will require infinite time? (The same is true for the plane and space). The mathematical sense of derivatives can not change as well. One of GRT demonstrations “on the inevitability of the change of geometry in the non-inertial system” is as follow: in the rotating coordinate system, due to contraction of lengths, the ratio of the length of a circle to its diameter will be lower, than  $\pi$ . Note that nobody can draw a “new geometry” for this case: “non-existing” cannot be pictured. In fact, however, not only the true, but even the observed geometry will not change: whether the mathematical line will move or change as we move? Although the radius, which is perpendicular to the circle motion, must be invariable in the relativity theory, nevertheless, we suppose at first, that the circle will move radially. Let we have three concentric circles of almost the same radius (Fig. 2.1). We place the observers on these circles and number them in the order from the center: 1, 2, 3. Let the second observer be motionless,

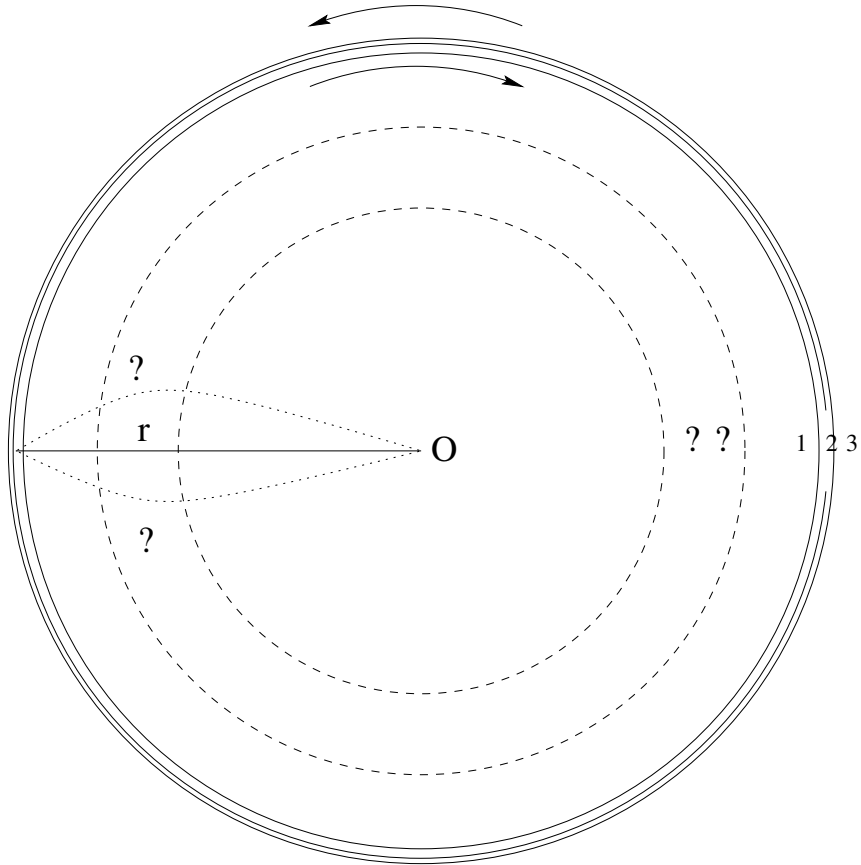

Figure 2.1: The geometry of a rotating circle.

whereas first and third ones are rotating around center  $O$  clockwise and counter-clockwise at the same angular velocity. Then, owing to the difference in relative velocities and contraction of lengths, the observers will interchange their places. However, when they happen to be at the same point of space, they will see different pictures. Indeed, the 1-st observer will see the following position from the center: 3, 2, 1, whereas the 2-nd observer will see the different order: 1, 3, 2, and only the 3-rd observer will see the original picture: 1, 2, 3. So, we have a contradiction. Suppose now, that the geometry of a rotating plane has changed. However, what will be more preferable in such a case: the top or the bottom? The problem is symmetric, in fact; to what side the plane has curved in such a case? If we make the last supposition, that the radius has curved (as the apparent motion changes in the non-inertial system), then the second observer will see it as non-curved, whereas the first and third observers will consider it as “curved” to different sides. Thus, for all cases, three observers will see different pictures at the same point for the same space; therefore, the curvature is not an objective fact (and cannot be a matter for scientific enquiry).

The rotating circle proves the contradictive nature of SRT and GRT ideas. Really, according to the textbooks, the radius, which is perpendicular to the motion, does not change. Therefore, the circumferences will remain at their places irrespective of the motion. Let us seat the observers on a motionless circle at equal distances from each other and produce a point-like flash from the center of a circle, in order the observers to draw the strokes on a moving circle at the time of signal arrival (Fig. 2.2). Owing to the symmetry of a problem, the strokes will also be equidistant. At subsequent periodic flashes (with the appropriate period) each observer will confirm, that a stroke mark passes by him at the flash instant, that is, the lengths of segments of motionless and rotating circles are equal. When the circle stops, the marks will remain at their places. The number of equidistant marks will not change (it equals to the number of observers). Therefore, the lengths of segments will be equal in the motionless case as well. Thus, no contraction of lengths

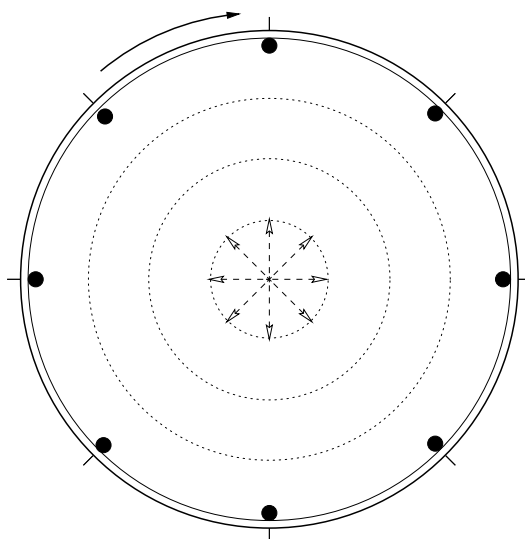

Figure 2.2: Equidistant observers at a circle.

(and change of geometry) took place at all.

Now we consider again the space geometry problem, but with the other approach. This problem is entirely confused still since the times of Gauss, who wanted to determine the geometry with the help of light beams. The limited nature of any experiment cannot influence the ideal mathematical notions, does it? Note, that in GRT the light even moves not along the shortest path: instead of Fermat's principle  $\delta \int dl = 0$ , we have in GRT [17]:  $\delta \int (1/\sqrt{g_{00}})dl = 0$ , where  $g_{\alpha\beta}$  is metric tensor. What does distinguish and pick out the light in such a case? The necessity of changing the geometry is often "substantiated" in textbooks as follows: in order the light to "draw" a closed triangle in the gravitational field, the mirrors should be turned around at some angle; as a result, the sum of angles of a triangle will differ from  $\pi$ . However, for any point-like body and three reflectors in the field of gravity (see Fig. 2.3) the

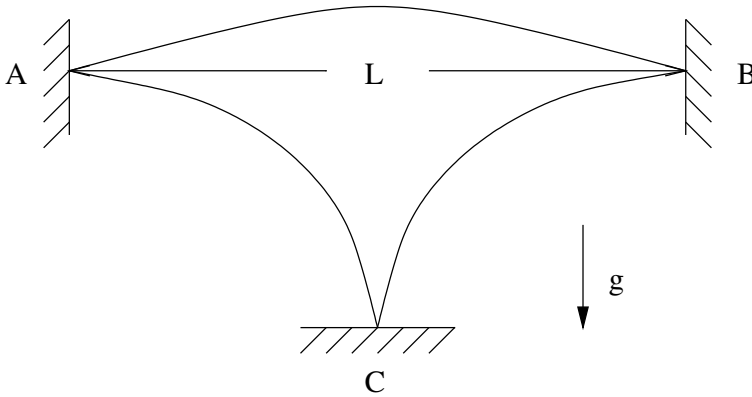

Figure 2.3: “Geometry of a triangle”.

sum of “angles” can be written as:

$$\sum \beta_i = \pi + 4 \arctan \left( \frac{gL}{2v_0^2} \right) - 2 \arctan \left( \frac{gL}{v_0^2} \right).$$

It occurs, that the geometry of one and the same space depends on the conditions of the experiment: on  $L$  and  $v_0$ . Since the angle  $\alpha$  between the mirrors  $A$  and  $B$  can also be changed (we chose  $\alpha = 0$  in our Fig. 2.3), we have a possibility of artificial changing the geometry within wide limits. Note, that the same variable parameters  $\alpha$  and  $L$  remain for the light as well. In such “plausible” proofs of the necessity of changing the geometry some important points are not emphasized. First, both in the experiment with material points, and in the experiment with the light the geometry is “drawn” sequentially during some time, rather than instantaneously. Second, for accelerated systems the particles (and the light) move in vacuum rectilinearly, according to the law of inertia, and, actually, the motion of the boundaries of this accelerated system is imposed on this motion additively. All angles of incidence (in the laboratory system) are equal to corresponding angles of reflection, and the “geometry of angles” does not change at all. Simply, the figure is obtained un-

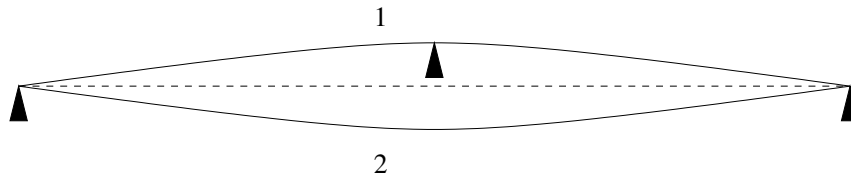

Figure 2.4: Drawing of the straight line in the gravitational field.

closed because of motion of the boundaries. Third, the role of the boundaries is not uncovered at all in determining the relations between the lengths of real bodies. For example, if all points of a real body are subject to the effect of identical accelerating force, then the mutual relation between lengths and angles (the “geometry”) remains unchanged. If, however, only the boundaries are subject to acceleration, then all real changes of bodies’ size take place only at interaction with the boundaries. In any case the Euclidean straight lines can be drawn. For example, to draw the horizontal straight line in the gravitational field we take two similar long rods (Fig. 2.4). At the middle of the first rod we install a point-like support. As a result of bending of a rod, the upward-convex line is generated. Then we install two point-like supports for the second rod at the level of two lowered ends of the first rod. As a result of bending of the second rod, the downward-convex line is generated. The middle line between these two bonded rods determines the straight line.

### The equivalence principle

Now we shall turn to the next important GRT notion – the equivalence of the gravitational field to some system non-inertiality. In contrast to any non-inertial system, the gravitational field possesses some unique property: all moving objects deflect in it toward a single center. If we generate two light beams between two ideal parallel mirrors and direct them perpendicular to mirrors, then in the inertial system these beams will move parallel to each other for infinitely long time. A similar situation will take place at acceleration



in the non-inertial system, if the mirrors are oriented perpendicular to the direction of acceleration. And, on the contrary, in the gravitational field with similar orientation of mirrors the light beams will begin to approach each other (Fig. 2.5). And, if some effect will happen to be measured during the observation, then, owing to a great value of light speed, the existence of namely the gravitational field (rather than the system non-inertiality) can also be identified. Obviously, the curvature of mirrors should not be taken into consideration, since, along with gravitational forces there exist also the other forces, which can retain the mutual configuration of mirrors. The distinction of a spherical symmetry from planar one can be found for weak gravitational fields as well. The GRT conclusion on the possibility of excluding the gravitational field for some inertial system during the whole observation time is wrong in the general case.

The equivalence principle of the gravitational field and acceleration can be related to one spatial point only, i.e. it is unreal. It already led to a false result for the light beam deflection in the gravitational field, for example (only later Einstein corrected the coefficient in two times). The equivalence principle for the inertial and gravitating mass can be rigorously formulated also for a separate body only (it is unreal for GRT, since GRT involves interdependence of the space-time and all bodies). Because of this, from the physical viewpoint, GRT cannot possess possibility for passage to the limit to any non-relativistic theory at all (but formally mathematically only). All relativistic linear transformations can be related to empty space only, since real bodies (even simply as reference points) lead to nonlinear properties of the space. Therefore, differences of phenomena with changing reference systems must be studied for the same point (in the space and time). But how can two different observers be placed at one and the same point? Therefore, the relativistic approach can possess the approximate model character only (without globality).

It is not any surprising thing, that one and the same physical quantity – a mass – can participate in different phenomena: as a

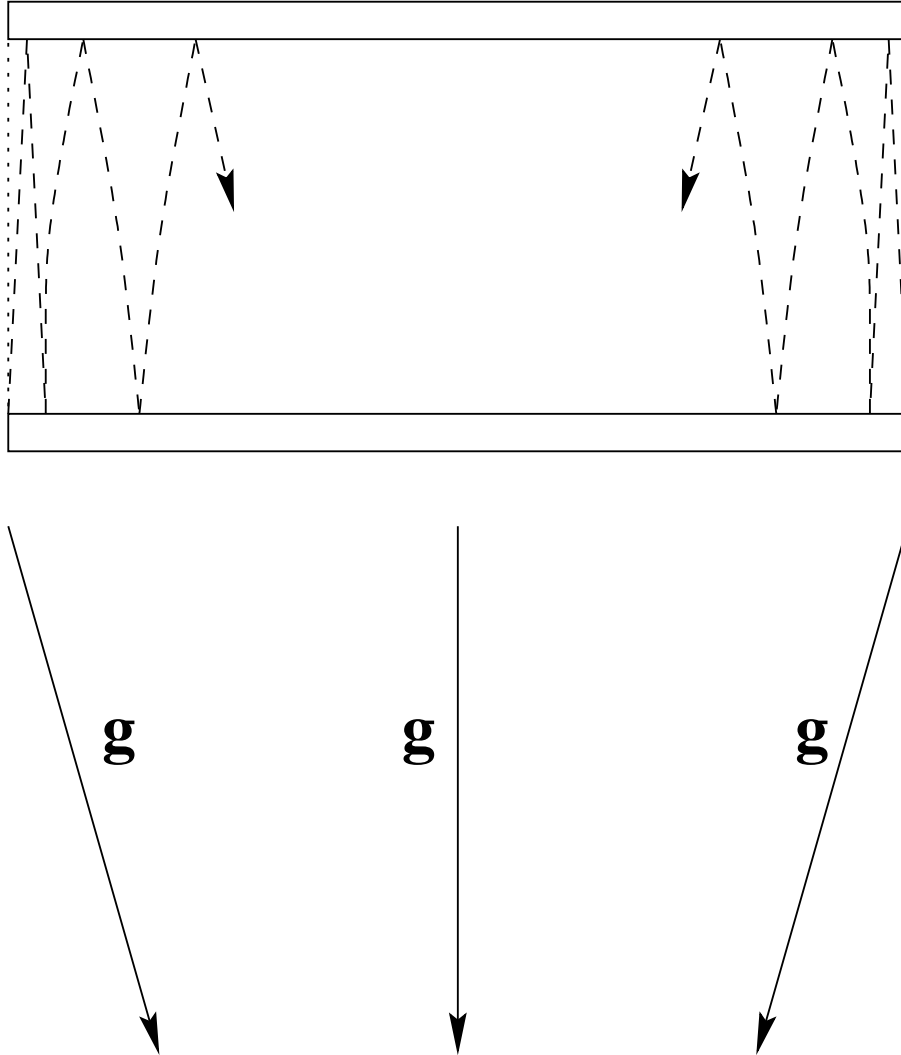

Figure 2.5: Rapprochement of parallel light beams in the gravitational field.

measure of inertness for any acting forces, including the gravitational one, and as a gravitating mass (for example, a moving charge produces both electric and magnetic fields). The question on the rigorous equality of inertial and gravitating masses is entirely artificial, since this equality depends on the choice of a numerical value of the gravitational constant  $\gamma$ . For example, expressions (laws) retain the same form in the case of proportionality  $m_g = \alpha m_{in}$ , but the gravitational constant will be defined as  $\gamma' = \alpha^2 \gamma$ . It is not necessary to search any mystics and to create pictures of curved space. The using one and the same value for the inertial and gravitating mass is made not only for GRT, but for the Newton's theory of gravitation as well. It is nothing more than an experimental fact (more precisely, the most simple choice of the value  $\gamma$ ).

When the author of [37] claims to the dependence of a form of equations on space-time properties, this idea contains some speculation. The false impression is given that we can change this space-time to check the dependence claimed. In fact, the Universe is only one (unique). GRT tries to add a complexity of the whole Universe to any local phenomena, which is not positive for science. The choice of local mathematical coordinates is a different matter (a phenomenon symmetry can simplify the description in this case) and globality has no matter again.

The use of non-inertial systems in GRT is intrinsically contradictory. Really, in a rotating system rather distant objects will move at velocity greater than light speed; but SRT and GTR assert, that the apparent velocities should be lower, than  $c$ . However, the experimental fact is as follows: the photograph of the sky, taken from the rotating Earth, indicates, that the visible solid-state rotation (classical) is observed. The use of a rotating system (the Earth, for example) does not contradict the classical physics at any distance to the object from the center, whereas in GRT the value of  $g_{00}$  component becomes negative, but this is inadmissible in this theory. What should we do with the terrestrial astronomical observations in such a case?

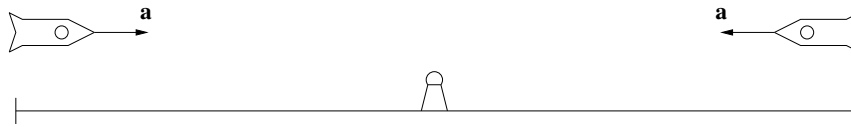

Figure 2.6: The fly of twins with an acceleration.

### Time in GRT

The concept of time in GRT is also confused to the limit. What does the clock synchronization mean, if it is possible only along the non-closed lines? The change of the initial moment of time reference point in moving around a closed path is an obvious contradiction of GRT, since at a great synchronization rate many similar passes-around can be made, and arbitrary aging or rejuvenation can be obtained. For example, if we imagine the vacuum (emptiness) to be rotating (if we ourselves will move around a circle), we can get various results depending on mental representations.

If we momentarily believe in the dependence of the GRT time on the gravitational potential and believe in the equivalence of gravitation and non-inertiality (an acceleration), then it could be easily understood that time must depend on the relative acceleration in this case (this is an extended interpretation). Truly, different accelerations must correspond to different gravitational potentials in this case, and conversely. But relative accelerations possess the vector character (and it cannot be “hidden”), that is the extended interpretation is the only possible one. Using the modified paradox of twins [51] for extended interpretation, the independence of time on acceleration can easily be proven. Let two astronauts – the twins – are at a great distance from each other. On a signal from the beacon located in the middle, these astronauts begin to fly toward the beacon with one and the same acceleration (Fig. 2.6). Since in GRT the time depends on the acceleration and the acceleration has relative character, each of the astronauts will believe, that his twin brother is younger than he is. At meeting near the beacon they

can exchange photos. However, owing to the problem symmetry, the result is obvious: the time in an accelerated system flows at the same rate, as in non-accelerated one. Besides, each astronaut (third observer can be placed at the beacon) can send the signals to the other one about his each birthday. Up to astronauts meet at the beacon, each of astronauts will perceive one and the same number of light spheres (the spheres can hide nowhere). Having received a “telegram” about 50th birthday of the brother a minute before the meeting, whether the other astronaut will congratulate the brother on his 5th birthday (maybe, he needs the oculist)? If we suppose the gravitational field to be equivalent to the acceleration (according to GRT), then we obtain, that the time intervals (time course) do not depend on the gravitational field presence. For example, the extend interpretation which includes the relationship between time course and acceleration can be easily disproved in the following manner. Let us consider several mans in different parts of the Earth. If we will use the GRT equivalence of the gravitational field and an acceleration, then, to imitate the terrestrial attraction, they must be accelerated from the Earth’s center, that is in different directions (all acceleration vectors will differ their directions). Therefore, all relative accelerations will be different. Owing to the problem symmetry, the result is obvious: the age of these mans will be independent on their location (i.e. on their acceleration).

Now we make some remarks concerning the method of synchronization of times by means of a remote periodic source disposed perpendicular to the motion of a body [48]. We begin with inertial systems. The possibility of time synchronization on restricted segments of the trajectory makes it possible to synchronize the time throughout the line of motion (Fig. 2.7). Indeed, if for each segment there exists an arbitrarily remote periodic source  $N_j$  sending the following information: its number  $N_j$ , the quantity  $n_j$  of passed seconds (the time reference point is not coordinated with other sources), then the observers at junctions of segments can compare the time reference point for a source on the left and for a source on the right. Transmitting this information sequentially from the first observer to the

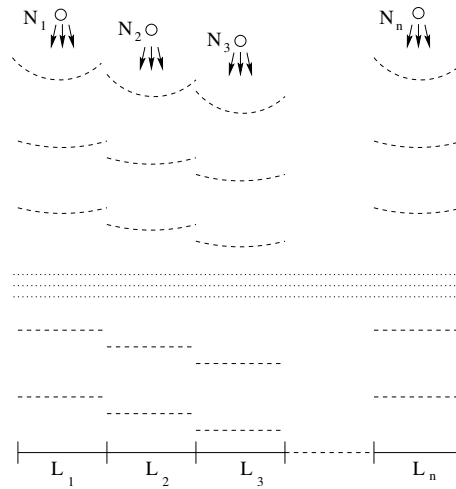

Figure 2.7: The time synchronization throughout the line of motion.

last one, it is possible to establish a single time reference point (the time itself, as it was shown in Chapter 1, has absolute sense [48]).

Obviously, the observed rate of transmission of synchronization signals has no effect on the determination of duration of times: the pulses (for example, light spheres or particles), which mark the number of passed seconds, will equidistantly fill the whole space, and the number of spheres emitted by a source will be equal to the number of spheres, which reach the receiving observer. (We are not the gods to be able to introduce the “beginning of times”: the time takes already its normal course and elapses uniformly.) Even if we consider the apparent signal propagation rate to be  $c = c(\mathbf{r})$ , then, irrespective of the path of light, the number of spheres reached the receiving observer (which has a zero velocity component in the source direction) will be the same as the number of spheres emitted by a source (simply, the spheres can be spatially condensed or rarefied somewhere). Time as the duration will be perceived uniformly. Thus, the full synchronization is possible in the presence of spatial inhomogeneities (of the gravitational field) as well.

We would remind two well-known experiments which were urgently ascribed by relativists to GRT advantages. The Hafele-Keating's experiment consisted in the following: two pairs of cesium atomic watch flew at an airplane in the east and west directions, and their readings were compared with the resting watch (in so doing the SRT "velocity effect" was taken into consideration, but its lack was proved in Chapter 1 of the present book). The Pound-Rebka's experiment consisted in the following: using the Mossbauer effect, a frequency shift was detected for a photon which passed some distances in the vertical directions (both up and down). In physics it is not accepted to take into account the same effect twice. It is clear, that the acceleration and gravitation express some force, that influences various processes. But this will be the general result of the effect of namely the forces. For example, not any overload can be withstood by a man, the pendulum clock will not operate under zero gravity, but this does not mean, that the time stopped. Therefore, the rough Hafele-Keating's experiment states the trivial fact, that the gravitation and acceleration somehow influence the processes in a cesium atomic watch, and the high relative accuracy of this watch for a fixed site has no matter at all. Besides, interpretation of this experiment contradicts the "explanation" of the Pound-Rebka's experiment, which supposes independence of frequency of emission in "the units of intrinsic atom time" [3] on gravitational field. Besides, a further uncertainty in GRT must be taken into consideration: there can exist immeasurable rapid field fluctuations (with a rate greater than inertness of measuring instruments) even in the absence of the mean field  $\mathbf{g}$ . Such the uncertainty exists for any value of  $\mathbf{g}$ : since the time in GRT depends on the gravitational potential, then an effective potential will be nonzero even with  $\langle \mathbf{g} \rangle = 0$ .

Whether is it possible to invent, though theoretically, a precise watch, which can be worn by anybody with himself? Probably, a rotating flywheel with a mark (for the absence of friction – on a superconducting suspension), whose axis is directed along the gravitational field gradient (or along the resultant force for non-inertial systems) could read out the correct time. At least, no obvious rea-

sons and mechanisms of changing the rotation rate are seen in this case. Certainly, for weak gravitation fields such a watch will be less accurate at the modern stage, than cesium one. Outside the criticism of relativity theory, we hypothesize, that atom decay is anisotropic, and this anisotropy can be interrelated with a direction of the atomic magnetic moment. In this case we can regularize atomic moments and freeze the system. Then, the “frozen clock” will register different time depending on its orientation in the gravitational field.

Now we return to synchronizing signals (for simultaneous measurement of lengths, for example). For a rectilinearly moving, accelerated system it is possible to use the signals from a remote source being perpendicular to the line of motion, and for the segment of a circle the source can be at its center. These cases actually cover all non-inertial motions without gravitation. (Besides, for the arbitrary planar motion it is possible to make use of a remote periodic source being on a perpendicular to the plane of motion.) For the real gravitational field of spherical bodies in arbitrary motion along the equipotential surfaces it is possible to use periodic signals issuing from the gravitational field center.

Note, that to prove the inconsistency of SRT and GRT conclusions on the change of lengths and time intervals it is sufficient, that the accuracy of ideal (classical) measurement of these values could principally exceed the value of the effect predicted by SRT and GRT. For example, for a synchronizing source being at the median perpendicular to the line of motion we have for the precision of the time of synchronization:  $\Delta t \approx l^2/(8Rc)$ , where  $l$  is the length of a segments with the synchronized time,  $R$  is the distance to the synchronizing source; that is,  $\Delta t$  can be decreased not only by choosing the great radius of a light sphere, but also by choosing a small section of motion  $l$ . From the SRT formulas on time contraction we have for the similar value:  $\Delta t = l(1 - \sqrt{1 - v^2/c^2})/v$ . If for finite  $R$  and specified speed  $v$  we choose such  $l$ , that the inequality

$$l/(8Rc) < (1 - \sqrt{1 - v^2/c^2})/v, \quad (2.1)$$



be met, then the conclusions of relativistic theories occur to be invalid.

For the system arbitrarily moving along the radius (drawn from the gravitational field center) it is possible to use for synchronization a free falling periodic source on the perpendicular to the line of motion. In this case  $R$  should be chosen of such value, that the field cannot actually change (due to equipotential sphere rounding) at this distance, and corresponding  $l$  from (2.1) near the point, to which the perpendicular is drawn. Therefore, the GRT conclusions can be refuted in this case as well. For the most important special cases the “universal” SRT and GRT conclusions on the contraction of distances as a property of the space itself are invalid. In the most general case it seems intuitively quite obvious, that such a position of a periodic source can be found, that the signal to come perpendicular to the motion, and that such  $R$  and  $l$  from (2.1) to exist, which refute the GRT results. There is no necessity at all in a “smeared” frame of reference and in an arbitrarily operating clock: any change of real lengths should be explained by real forces; it is always possible to introduce a system of mutually motionless bodies and the universal time (even if it were the recalculation method). Thus, the space and time must be Newtonian and independent on the motion of a system.

### Some GRT corollaries

Now we pass to mathematical methods of GRT and to corollaries of this theory. The games with the space-time properties result in the fact, that in GRT the application of variation methods occurs to be questionable: the quantities are not additive, the Lorentz transformations are non-commutative, the integral quantities depend on the path of integration. Even it is not clear, how the terminal points can be considered as fixed, if the distances are different in different frames of reference.

Because of nonlocalizableness (non-shieldness) of gravitation field, conditions on infinity (because of the mass absence on infinity,

it is euclideaness) are principally important for the existence of the conservation laws in GRT (for systems of the insular type only) [37]. The classical approach is more successive and useful (theoretically and practically): energy is determined correctly to a constant, since only the local energy difference between two transition points has a physical meaning. Therefore, conditions on infinity have no matter.

The procedure of linearization in the general form is very doubtful, since it can be only individual. The aspiration for simplicity is declared, but even two types of time are introduced – coordinate and intrinsic time. Often, fitting is done to the well-known or intuitive (classically) result. So, for example, one of the signs is selected when calculating the deflection of a light beam; similarly, for the motion of the perihelion of Mercury [3], the derivative  $du/d\varphi$  can have two signs. Which of them should be chosen? Not to mention the fact that dividing by the quantity  $du/d\varphi$  is performed, but this derivative can be zero. The complexity of spatio-temporal relationships is declared, but as a result, it takes a very long time to proceed to the usual mathematical coordinates, otherwise there is nothing to compare the results with. For what was the struggle? For pseudo-like-science (sciolism)?

Till now there is no sufficient experimental proof of whether the rate of transmission for gravitational interactions is higher than, lower than, or exactly equal to the light speed (as is postulated in GRT). For example, on the basis of observations, Laplace and Poincare believed [24,87] that the rate of transmission of gravitational interactions is several orders greater than the light speed.

Now we consider the experimental substantiation of the GRT. Usually, even if there exists a hundred different data, a theory is constructed not always: it is easier to summarize the data in a table. But in the case of the GRT, we see “the Great theory of three and a half observations”, three of which are the fiction. Concerning the light deflection from rectilinear motion in a gravitational field, we should make the following statements. First, as it was pointed out by most experimenters, the quantitative verification of the “advertised” effect depended essentially on the faith of the concrete ex-

perimeter. In detail, you can read in the article by G. Ivchenkov about what Lord Eddington actually measured [202]. Second, as it follows already from the classical formula  $m\mathbf{a} = \gamma m M \mathbf{r}/r^3$ , any object (even of zero or of negative mass) will falling down in the gravitational field. Third, with which a value does the effect be compared? With a value in empty space? As early as 1962, a group of Royal astronomers declared that the light deflection near the Sun cannot be considered as confirmation of GRT, because the Sun has an atmosphere stretching for a great distance. We would remind that the effect of refraction is long taken into account by astronomers for the terrestrial atmosphere. Lomonosov discovered the deflection of a light beam in the atmosphere of the Venus long ago. For explanation, imagine a glass **sphere**. Naturally, parallel rays (from distant stars) will be deflected to the center in it. Such a system is well known as an optical lens. The similar situation will take place for a **gas sphere** (the Sun's atmosphere). For accurate calculation of light beam deflection in the gravitational field, one should take into account that the presence of the solar atmosphere and the fact, that the presence of density and temperature gradients on the beam path causes changes to the medium's refractive index and, hence, to the bending of the light beam. And if these effects cause a mirage for a distance of hundreds of meters near the earth's surface, then their ignoring, when a star ray is passed millions of kilometers near the Sun, is pure speculation.

The displacement of the perihelion of Mercury is, of course, an interesting effect, but whether the sole example is sufficient "to attract" a scientific theory, or not? Therefore, it would be interesting to observe it near solid bodies (for satellites of the planets, for instance), so that the value of this effect could be estimated for certainty. The matter is that the Sun is not a solid body, and the motion of Mercury may cause a tidal wave on the Sun, which may in turn also cause a displacement of Mercury's perihelion. (Depending on the rate of transmission of gravitational interactions and "hydrodynamic" properties of the Sun, the tidal wave may either outstrip, or lag behind the motion of Mercury.) In any case, it is necessary

to know the rate of transmission of gravitational interactions for calculating the effect of a solar tide due to motions of the Mercury and other planets on Mercury's orbit characteristics, in order that the purely "gravitational" effect of the GRT could be separated (if this "pure" effect exists at all).

When calculating the displacement of perihelion in GRT (from a rigorous solution for the single attracting point), the impression arises, as if we allegedly know the exact masses of astronomical bodies. In fact, if we use GRT as a correction to Newton's theory, the situation is opposite; there arises a problem: using the visible planet motions, to reestablish the exact planet masses and to substitute them in the GRT for checking it thereafter. Imagine that the planet orbit is circular. In this case, it is immediately obvious that the period of rotation in Newton's theory will already be taken with taking into account the invisible precession, that is, the period will be renormalized. Therefore, renormalized masses of planets are already included in Newton's gravitation theory. Since the GRT-corrections are much less than the perturbing action of planets and the influence of a non-sphericity, then the reestablishment of exact masses can essentially change the description of a picture of the motion for this complex many-body problem. No such detailed analysis was carried out.

Generally speaking, the situation with description of the displacement of the Mercury's perihelion is typical for relativist's behaviour. First, it was declared that the effect allegedly was predicted, but Einstein compares it with the well known results of approximate calculations, which was produced by Laplace long before origin of the GRT. Hope, each man understands a great difference between "predict" and "explain after the event" (remember the appropriate anecdote of Feynman). Second, the most part of precession was found already in classical physics: the data of 19th century was calculated with taking into account influences of some planets. The result obtained was the value of  $588''$ , whereas a deficiency in the calculated value make up about  $43''$  only, that is a small correction. (Note, that some data of 20th century indicate the total

value of precession to be about 10 times higher than mentioned one, but the “deficiency for GRT” in 43” is maintained – it is “taboo”; however, it could be a misprint and we will not cavil to 1/3 part of “the great experimental base of GRT”). Third, the exact calculation for a many-body problem cannot yet be made even by the modern mathematics. In classical case the calculation was made as a sum of independent corrections from influences of separate planets (the Sun and planets were considered in pairs as material points). Naturally, the classical ultimate result (more than 90 % from observable one!) can some more be improved with taking into account the solar non-sphericity, influences of all planets (including small bodies) of the solar system, the fact that the Sun is not a solid object (a material point) and its local density in different layers must “follow” influences of other moving planets. Most probably, this way of using real physical mechanisms can lead to replenishment of the deficient small effect. But the relativistic declaration is inconceivable speculation! They “found” an effect (this small procent only) considering motions of two material points only – the Sun and the Mercury. Excuse me, but how will your GRT rectify the most part of the effect already found from the classics? Do you fear to re-calculate? Then on what “a brilliant coincidence” do you repeat? This is a pure machination for the desired result!

And the work of the founder of the relativistic “explanation” for the displacement of the perihelion of Mercury [41, pp. 439-447] contains elementary mathematical errors. Thus, the classic did not notice that the application of the well-known from algebra Vieta’s theorem on the sum of the roots of an algebraic equation to the derived (with machinations) cubic equation leads to the condition

$$\frac{1}{\alpha} = \alpha_1 + \alpha_2 + \frac{1}{\alpha}, \Rightarrow \alpha_1 + \alpha_2 = 0, \Rightarrow \phi = \pi,$$

that is, no displacement follows from Einstein’s “calculations”. A more detailed analysis of Einstein’s article can be found in [146].

The prototype of the “black hole” in Laplac’s solution, where the light, moving parallel to the surface, begins to move over a circle like the artificial satellite of the Earth, differs from the GRT

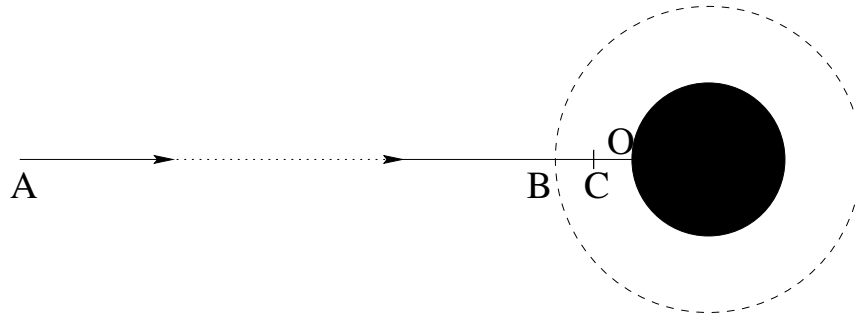

Figure 2.8: The fall on a “black hole”.

ideas. Nothing prohibits the light with a rather high energy to escape the body in the direction perpendicular to its surface. There is no doubt, that such beams will exist (both by internal and external reasons): for example, the beams falling from outside will be able to accumulate energy, in accordance with the energy conservation law, and to leave such a “black hole” after reflection from it. Instead of invoking contradictory properties of light, we can simply consider the “fall” of an elementary particle – an electron, for example. Whether the possibility of the elastic reflection is maintained for it, or such the possibility must postulatively be forbidden (to rescue the GRT)? And if such the possibility is not forbidden, then we consider the following process. Let an electron be coming into fall with the zero start velocity from a distant point  $A$  (at the distance 100 a.u., for example) to a very massive body (Fig. 2.8). The body absorbs “last surplus nearest molecules” and becomes the “black hole” in a matter of an instant before the electron crosses the Schwarzschild sphere (which is marked as  $B$  on the picture). To be visual, the distance  $|OB|$  is shown comparatively large. In a matter of an instant before the collision of the electron with the surface of the “black hole”, the latter object was stable, and since neither velocity nor acceleration of this surface can instantly become very large (besides, the collision can take place with a particle flying to

meet), then at the elastic collision the electron will fly to the point  $A$  with just the same speed as it acquires before the collision. Relativists claim that it cannot get over the Schwarzschild sphere  $B$ . Let it come to a stop at the point  $C$  (at the distance 10 km from the body center, for example). If the energy conservation law is obeyed, and since the electron's velocity equals to zero at the points  $A$  and  $C$ , then the potential energy of the electron at the point  $A$  is equal to the potential energy at the point  $C$ . Therefore, the gravitational field (attractive forces) is absent between the points  $A$  and  $C$ , or else the potential must be monotonically decreasing. However, the consideration of the situation purely from the GRT positions leads to the still worse result (see below). The "black holes" in GRT is a real mysticism. If we take a long rod, then at motion its mass will increase and the size will decrease (according to SRT). What will happen? Is the "black hole" generated? All the sky will become filled with "black holes", if we shall move rapidly enough. And, you see, this process would be irreversible in GRT. For example, any object of the Universe is a "black hole" for fast moving light (how light can exist?).

Recall some well-known solutions: 1) the Schwarzschild solution describes the centrally symmetric static "field" in vacuum (note that the temperature characteristics are absent, i.e.  $T = 0\text{K}$ ); and 2) the axially symmetric Kerr's metric describes the "field" of a rotating collapsing body. The presence of multiple connection of the solution or singularities implies, that, as a minimum, the solution is inapplicable in these regions. Such a situation takes place with the change of the signature of space-time in the Schwarzschild solution for the "black hole", and it is not necessary to search any artificial philosophical sense in this situation. The singularity in Schwarzschild's solution for  $r = r_g$  cannot be eliminated by purely mathematical manipulations: the addition of the infinity with the other sign at this point  $r$  – is the artificial game with the infinities, but such a procedure requires the physical basis. (As you understand, in other fields of physics, all singularities at zeros are not eliminated by artificial addition of  $\alpha \exp(-\lambda r)/r$ , where  $\lambda$  is a large quantity). Note

that the strict solution of Einstein's gravitational field equations found by V.A. Fok (in harmonic coordinates) has a singularity at a different value  $r = r_g/2$  (which indicates the ambiguity of GRT). Moreover, there exists also a solution by V. Pauli with a singularity at  $r = r_g/4$  (aren't there too many ambiguous singularities?). Further, in a rotating coordinate system, GRT does not satisfy the correspondence principle: in the limit, it does not pass to classical physics (inertia forces do not appear).

Even from GRT follows the unobservability of "black holes": the time of the "black hole" formation will be infinite for us as remote observers. even if we had waited for "the End of the World", not a single "black hole" would have had time to form. And since the collapse cannot be completed, the solutions, which consider all things as though they have already happened, have no sense. The separation of events by infinite time for internal observer and external observer is not "an extreme example of the relativity of the time course", but the elementary manifestation of the inconsistency of the Schwarzschild solution. The same fact is demonstrated by the "incompleteness" of systems of solutions. It is not clear, what will happen with the law of charge conservation, if a greater quantity of charges of one and the same sign will enter the "black hole"? The mystical description of "metrical tidal forces" [39] at approaching the "black hole" is invalid, since it would mean, that the gravitation force gradient is great within the limits of a body, but all GRT ideas are based on the opposite assumptions. In the presence of rotation, the Kerr metric also clearly demonstrates the inconsistency of GRT: in a strict mathematical manner, it gives several physically unreal solutions (the same operations, as for Schwarzschild's metric, do not save the situation). Thus, such the GRT objects as the "black holes" cannot exist and they must be transferred from the realm of sciences to the province of the non-scientific fiction. The entire Universe is evidence of the wonderful (frequently dynamical) stability: there do not exist infinite collapses (an explosion can happen rather). All this does not cancel a possibility of the existence of superheavy (but dynamically stable) objects which can really be manifested by sev-



eral effects (for example, by accretion, radiation etc.). No the GRT fabrications are required for these purposes at all. We have no need to seek ways for the artificial rescue of the GRT, such as the “evaporation of the black holes”, since such a possibility is strictly absent in the GRT (the speed of light cannot be overcome). On the contrary, in classical physics no problems exist at all.

GRT contains a lot of doubtful prerequisites and results. We list some of them. For example, the requirement of gravitational field weakness for low velocities is doubtful: If you land an apparatus on a massive planet, can it really not be able to stand or move slowly? Is it possible that, despite the temperature fluctuations, there will not be molecules with low velocities? The consideration of a centrally symmetric field in GRT has not physical sense as well: since the velocity can be only radial, then not only rotations, but even real temperature characteristics can not exist (i.e.  $T = 0 K$ ). The field in a cavity is not obtained in a single manner, but, simply, two various constants are postulated in order to avoid singularities.

The emission of gravitation waves for a parabolic motion (with eccentricity  $e = 1$ ) results in the infinite loss of energy and angular momentum, which obviously contradicts the experimental data.

In fact, GRT can be applied only for weak fields and weak rotations, i.e. in the same region, as the Newtonian theory of gravitation. Recall that the similar interaction between moving charges differs from the static Coulomb law. Therefore, prior to applying the static Newtonian law of gravitation, it must be verified for moving bodies, but this is a prerogative of the experiment.

Let us discuss one more principal point concerning the relativity of all quantities in GRT. The laws, written simply as equations, determine nothing by themselves. The solution of any problem still requires the knowledge of specific things, such as the characteristics of a body (mass, shape etc.), the initial and/or boundary conditions, the characteristics of forces (magnitude, direction, points of application etc.). The “reference points” are actually specified, with respect to which the subsequent changes of quantities (position, velocity, acceleration etc.) are investigated. The principal relativity of

all quantities in GRT contradicts the experiments. The subsequent artificial attempt to derive accelerations (or rotations) with respect to the local geodesic inertial Lorentzian system – this is simply the fitting to only workable and experimentally verified coordinates of the absolute space (GRT does not contain any similar things organically [18]).

The gravitational constant is not a mathematical constant at all, but it can undergo some variations [9]. Therefore, this value can account corrections to Newton’s static law of gravitation (for example, these influences do not taken into consideration for the displacement of the perihelion of the Mercury). We are reminded that in finite moving (periodic, for example) different resonance phenomena can be observed for a coupled many-body system. The effect is manifested in a conformed correction of orbital parameters (especially taking into account a finite size of bodies: non-sphericalness of their form and/or of the mass distribution).

Generally speaking, the theory of short range for gravitation could be useful (but it can be not useful depending on the gravitation transmission rate) for the finite number of cases only: for the rapid ( $v \rightarrow c$ ) motion of massive bodies (of one and the same order) close to each other. The author does not know such practical examples.

Geometrization alone is clearly not enough to describe the dynamics of bodies. Let’s take several balls of the same size: air, wood, iron, lead. Let them begin to fall freely in the vacuum chamber at the same time, and at the bottom under them there are start buttons (guillotines, for example) with springs of one and the same high rigidity. Then, despite the completely identical kinematics of movement ( $x_i(t) \equiv x_j(t), v_i(t) \equiv v_j(t), a_i(t) \equiv a_j(t)$ ), only the button, on which the lead ball falls, will work. It also proves that systems of units, in which there exist only units of measurement (dimensions) [L] and [T], are not self-sufficient. A unit of measurement is needed that “switches on” the materiality of our World. Such a unit can be a unit of mass [M].

The GRT approach to gravitation is unique: to be shut in an elevator car (enjoying the fall) and to be not aware that the end

(hurt oneself) will be after a moment. Of course, the real state is quite different one: we see always where and how we move relative to the attractive center. In opposition to Taylor and Wheeler, this just is the second “particle”, together with the first “particle” – with the observer. That is the reason that the pure geometric approach is a temporal zigzag for physics (although it could ever be useful as a auxiliary technique). And two travelers in the parable from the book [33] (allegedly demonstrating the approach of the geometry of curved space) need “very little”: the desire to move from the equator exactly along meridians (along the spheric earth surface), but the remaining seven billion people may not have such the desire. In contrast to the desire of the travelers, no matter how much you wish not to be attracted to the Earth or the Sun and without effort to fly into space, your desire is clearly not enough. Such a phenomenon just reflects the concept of force (in this case, gravity). Geometry cannot answer to the following questions: How many types of interactions exist in nature, why there exist they only, why there exist localized masses, charges, particles, why the gravitational force is proportional just to  $r^2$ , why there realize the specific values of physical constants in nature, and many other questions. All these problems are the prerogative of the physics (experimental).

## 2.3 Criticism of the relativistic cosmology

The theories of evolution of the Universe will remain the hypotheses for ever, because none of assumptions (even on the isotropy and homogeneity) can be verified: “a moving train, which departed long ago, can be caught up only at the other place and at the other time”. GRT assigns to itself the resolution of a series of paradoxes (gravitational, photometric, etc.). Recall that the gravitational paradox consists in the following: it is impossible to obtain the definite value of the gravitational acceleration of a body from Poisson’s equation for the infinite Universe possessing a uniform density. (What relationship to the reality have purely mathematical uncertainties with conditions at infinity in some particular physical

model?) Recall also the essence of the photometric paradox: for the infinitely existing (stationary) infinite Universe the brightness of sky must be equal to the mean brightness of stars without considering the light absorption and transform (again we have rather many unreal assumptions). However, the classical physics has also described the possibilities of resolution of similar paradoxes (for example, by means of systems of different orders: Emden's spheres, Charlier's structures, etc.). Obviously, the Universe is not a smeared medium and we do not know its structure as a whole at all in order to assert the possibility of realization of the conditions for such paradoxes (more probably, the opposite situation is true). For example, the Olbers photometric paradox can easily be understood on the basis of the analogy with the ocean: the light is absorbed, scattered and reflected by portions, and the light simply ceases to penetrate to a particular depth. Certainly, such a "depth" is huge for the rarefied Universe. However, the shining stars represent rather compact objects spaced at great distances from each other. As a result, only a finite number of stars make a contribution into the light intensity of the night sky (not to mention the fact that in theory it is also necessary to take into account the Doppler effect, and even better – an experimental fact – redshift).

Regarding the redshift in the spectra of astronomical objects, the situation is not fully clarified. In the Universe there exists a considerable number of objects with quite different shifts in different spectral regions. Generally speaking, since distances to remote objects do not directly measured (the calculated result is connected with some hypotheses), then their relation with the redshift is hypothesis also (for which it is unknown what the matter could be verified). For example, the expanding of the Universe gives a redshift according to the Doppler effect irrespective of GRT. Besides, it should be taken into consideration, that even the elementary scattering will make contribution into the redshift and filling of the so-called relict radiation: recall that the Compton effect gives waves with  $\lambda' > \lambda_0$ . The shift of lines in the gravitational field has been well predicted even by mechanistic models from the general energy

considerations.

Generally speaking, the theory of Big Bang casts the Big doubts. In addition to the banal questions: “What, to where and when was exploded?” (since space, time and substance did not exist), the question arises: What about the GRT conclusion on black holes (and the insuperability of light speed)? After all, at the time of the origin, the Universe must be a black hole (and not only at this zero time instant, but throughout some period). What about the limitations of GRT, because now instead of such a figurative description of the compression in a black hole, we are experimentally observing a ubiquitous expansion? Probably, it is interesting to invent something that cannot be verified (just does not worth to name it science).

Now we pass to the following principal issue. Whether positive is the fact, that the distribution and motion of matter cannot be set arbitrarily? And whether is it correct? In the general case, this means the theory is inconsistent, since in addition to gravitational forces, there exist other forces that are also capable to move matter. From the practical viewpoint this means, that we should specify all distributions in the “correct-for-GRT” manner also at the initial time instant. In such a case, we should attribute any initial moment  $t_0$  to “the zero time of creation of the Universe”, did we? And what principles should be unambiguously determined for such a choice? This requires more knowledge, than any possible results are expected from GRT predictions. The possibility of a point-like description and the perturbation theory turn out questionable, because the final values cannot be arbitrary either. The joining of a completely unknown equation of state to the system of equations implies artificial complication by linkage of macro and microlevels and reflects the possibility of arbitrary fittings (for example, the temperature dependence is omitted). The possibility of adding the cosmological constant into Einstein’s equations is an indirect recognition of ambiguity of GRT equations and of the possibility of arbitrariness. If everything can be specified with such an accuracy, then why cannot we set in arbitrary manner the initial

distribution and the motion of matter?

We also note the completely futile attempt in [141] to distract to the discussion about the allegedly need to distinguish between coordinate systems (weightless - mathematics) and reference systems (material). Just mathematics is a universal science for describing any phenomena and comparing them with each other; it does not introduce disturbances into physical processes. Why artificially load the process under study with a massive system (additional objects), which in fact has nothing to do with this process? How can this help to find the cause and mechanism of the phenomenon under study?!

### **The Mach principle**

The Mach principle of stipulation of an inert mass and absolute nature of the acceleration due to the influence of far stars is also doubtful, since it explains the intrinsic properties of one body via the properties of all other bodies. Of course, the idea is elegant in itself. If everything in the world is supposed to be interdependent and some ideal complete equation of state is believed to exist, then any property of bodies should be determined by the influence of the whole remaining Universe. However, in such a case any particle should be considered to be individual. This way is faulty for science, which progresses from smaller knowledge to greater, since “it is impossible to grasp the immense”. In practice, if we take into account the non-uniform distribution of mass (in compact objects) and different values of attraction forces from close and far objects, then the nonuniform “jerking” would be obtained instead of uniform rotation or uniform inertial motion of an object.

The Mach principle cannot be verified in essence: both removal of all bodies from the Universe and mathematical tending of the gravitation constant to zero are the abstractions having nothing in common with the reality. However, it is possible to estimate the influence of “far stars” experimentally by considering the mass of the Universe as mainly concentrated in compact objects. The force of attraction of a star having a mass of the order of the Sun’s mass

$M \sim 2 \cdot 10^{30}$  kg, being at the distance of 1 light year  $\sim 9 \cdot 10^{15}$  m, is equivalent to the action of a load having a mass of only  $m_0 \sim 25g$  at the distance of 1 meter. We shall make use, for a while, of the doubtful Big Bang theory and shall consider the time for the Universe to be equal to  $\sim 2 \cdot 10^{10}$  years. Even if the stars fly away with light speed, we would have the size of the Universe equal to  $\sim 2 \cdot 10^{10}$  light years. We will suppose the mean distance between nearest stars in 1 light year. We have deliberately increased all quantities; for example, the mass of the Universe and its density  $\rho \sim 10^{33}/10^{54} \sim 10^{-21}$  g/cm<sup>3</sup> (the exact density of the Universe is unknown, but it is estimated as  $\rho < 10^{-28}$ g/cm<sup>3</sup>). We take into account now, that, as the bodies move away from each other at the two-fold distance, the force decreases four-fold, etc. We try to imitate the effect (on a body) of the gravitational force from the Universe in some direction. Even if we suppose the mean distance between the nearest stars to be 1 light year, then at the distance of 1 meter it is necessary to place the mass (we sum up to  $2 \cdot 10^{10}$ ) of

$$M_0 \sim 25(1 + 1/4 + 1/9 + \dots) = 25 \sum 1/n^2 \sim 25\pi^2/6 < 50$$

grams. In fact, coefficient  $\pi^2/6$  expresses some effective increase of the density at the observation line. To simulate the action of the “whole Universe” we can take a thick metal sphere with outer radius of 1 meter and make its thickness varying in the direction to the center (to imitate heterogeneities, we can make the needle-shaped structure near the inner radius).

Let the thickness of a continuous spherical shell be 0.6 meters, i.e. from the center up to 0.4 meters there is a niche, and further, up to 1 meter, – the metal. Then a cylindrical column of radius  $\sim 0.35$  cm at density of  $\sim 8.3$  g/cm<sup>3</sup> will correspond to mass  $M_0$ . In reality, we should take into account the influence of stars in a cone, but not only in a cylinder. Though we also have a spherical metal cone, nevertheless, we shall estimate the orders of magnitudes. We shall break a cone into cylindrical layers, which arise as the new layers of stars are involved into consideration (Fig. 2.9). Each new layer will be greater, than a preceding layer, by 6 stars. The distances

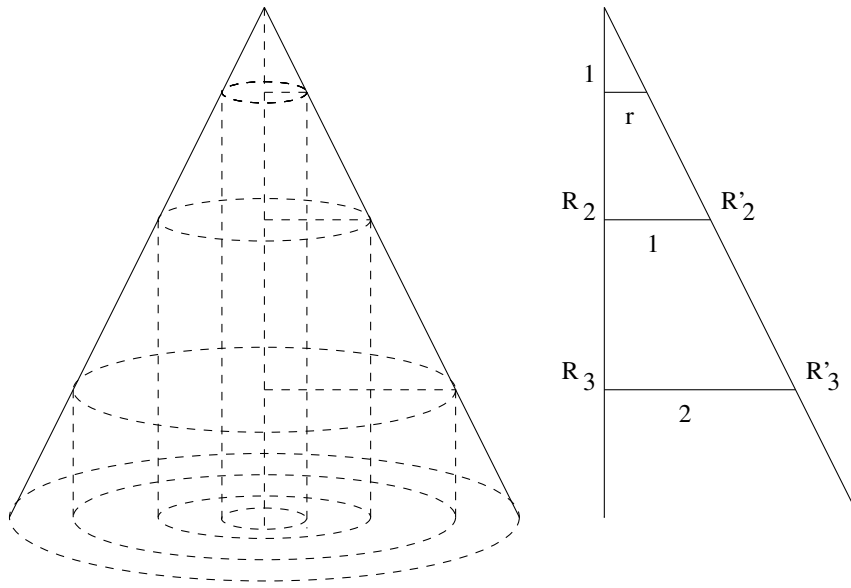

Figure 2.9: The Mach principle and influence of the Universe.



from the center to the nearest boundary of each layer of stars can be found from the similarity of triangles:  $R_i/1 = i/r$ . Then we have  $R'_i = \sqrt{i^2(1+r^2)}/r$ . Therefore, the correction to a mass (we sum up to  $2 \cdot 10^{10}$ ) will be found as

$$m_0\left(1 + \frac{1}{4} + \dots\right)\left(1 + \sum_i \frac{6}{R_i^2}\right) < M_0\left(1 + 6r^2 \sum_i \frac{1}{i}\right)$$

$$\sim M_0\left(1 + 6 \cdot 10^{-5} \log(2 \cdot 10^{10})\right) \sim M_0(1 + 0,02).$$

Thus, our construction is quite sufficient for taking into account the influence of the “whole Universe”. Certainly, if the Universe is infinite, then the obtained harmonic series will diverge, and the construction will be inadequate. This, however, contradicts both GRT and the modern ideas (observational data).

Let now place the globules on a spring inside the sphere. To avoid the collateral effects, the air can be pumped out from the structure and, in addition, the globules can be isolated from the sphere by a thin vessel. Now, if we begin to spin up the sphere, then, according to the Mach principle, the centrifugal force should appear, and the globules should move apart of each other. In this case the centrifugal force must be the same, as though the globules themselves would rotate. It seems quite obvious, that this is impossible, since such an effect would be noticed still long ago. Thus, we return to absolute notions of acceleration, mass, space and time defined still by Newton. However, the described experiment could appear to be useful for determining the corrections to the static Newton’s law of gravitation. For this experiment, the globules should have sufficient freedom to move and to rotate, since the direction of action of correcting forces and moments of forces is unknown a priori.

Generally speaking, conditionality of the very concept of mass (and of inertia forces) by the action of the all remaining Universe can be simply refuted. We take two identical scales and place them side by side. We take two cubes of the same size, but made of

different substances: polystyrene foam and lead (they will differ in mass by  $11350/10 = 1135$  times). Let's put one cube on one scale, and the second cube on another scale. Naturally, the scales show different weights of the cubes. Are you saying that this is determined by the action of the entire Universe? Wonderful! We leave the scales in their places, and very quickly swap the cubes. Naturally, that if the Universe was not "mirrored" relative to the plane separating the two scales (all constellations did not become mirror symmetrical, the Earth did not move in the opposite direction etc.), but for some reason if the mass (weight) moved together with its cube. Performing this operation multiple times produces the same results. Thus, "mass" reflects a local property of a particular object, but the influence of the entire Universe on a specific place in space is negligible, and Mach's beautiful nonsense with a claim to universality can also be consigned to the archives of history.

## 2.4 Dark Matter and Dark Energy

Recall that the conclusion about the existence of the so-called "dark matter" was made **only on the basis of indirect signs** of the behavior of astrophysical objects on the gravitational effects created by them. Contrary to modern theories, these were the following signs: the anomalously high rotational speed of the outer regions of galaxies (which does not decrease as  $R^{-1/2}$ , but, for example, for the Andromeda nebula remains approximately constant); estimation of the mass of galaxies from the motion of satellites of galaxies and nearby globular clusters; the stellar mass of elliptical galaxies is insufficient to hold the gas; estimation of the mass of galaxy clusters, by gravitational lensing. But maybe the theories and estimates themselves are wrong (these may be deviations from the gravitation law, as well as the presence of a rejected medium – ether [179])? On the one hand, it is postulated that dark matter does not interact with light, but, on the other hand, because it interacts with matter by the forces of gravity, then, contrary to the postulate, "light is emitted from where there is dark matter".

A study of 400 stars within a radius of up to 13,000 light years from the Sun did not reveal the presence of any kind of “dark matter”, i.e. it is useless to look for it near the Earth (but for larger distances – these are not verifiable fantasies). Consequently, there are some problems with modern theories in extrapolation over long distances, or some parameters are incorrectly estimated for distant objects.

Along with real objects, completely mythical (the existence of which remains at the level of faith) objects were suggested as candidates for the role of “dark matter”: black holes, quark stars, Q-stars, preon stars, primar black holes, Planck black holes (maximons). Relativistic physicists associate the dark matter with the invented problems of the Big Bang and relativistic cosmology. They offer fantastic particles for this role, invented to rescue some pseudoscientific theories: axions (supposedly solving the “problem” of strong CP-violation in quantum chromodynamics), mythical “supersymmetric” particles such as photino, gravitino, Higgsino, sneutrinos also fabulous topological defects of space-time, invented in the framework of the pseudo-theory of “vacuum phase transitions during the expansion of the Universe” (magnetic monopoles, cosmic strings, domain walls, textures).

If dark matter was initially in thermodynamic equilibrium with particles of the cosmic plasma, then how could the temperature drop so that this interaction would stop? For violation of sustainable equilibrium, very weighty reasons are needed (and effective mechanisms).

Regarding the hidden mass: a contradiction arises if the calculations of celestial mechanics take into account only objects visible in the optical range. However, even with the example of the Solar System, we see that besides the Sun itself (luminous), there are also planets with satellites, asteroids, meteorites, meteors, solar wind, dust, gas, etc. Thus, not all the mass in the process of evolution must concentrate in the stars. There is always a separatrix that separates the transit trajectories from trapped ones, and even for trapped trajectories, only a small fraction of the particles can get

to the center, since the main movement in this case is not straight, but circular (elliptical). This means that the astrophysical part of the problem under discussion may be associated with an incorrect assessment of the real mass and its evolution, as well as with distortion of the laws obtained in the laboratory under extrapolation over long distances. The cosmological part of the problem should not be seriously discussed at all, since this is a purely hypothetical area.

We make comments on the so-called Zwicky problem (masses of clusters of galaxies). We see only ray projections onto an infinitely distant sphere. We know exactly neither the distance to objects (and, therefore, their mutual arrangement), nor their relative velocities (even the radial projection of velocity is determined with faith in some hypotheses). We do not know from where, to where and how moved (flew) these objects during billions of years and, for scanty on the cosmic scale observation time (the lifetime of observational astronomy), it is almost impossible to predict the further evolution of these objects. So, the problem is purely hypothetical.

The so-called gravitational lensing is, first of all, ordinary gas lenses (of course, related to the total mass of objects, including the mass of gas). However, density and temperature gradients along the path of the beam also play a big role. Note that the rays falling on the Earth from each such extremely distant object have a **very narrow direction** and pass their specific, almost linear path with the optical path length  $s \cdot n(s)$ . However, rays that have passed through different paths can get to one point. Therefore, there is nothing surprising in obtaining several different clear images. The Lyman-alpha forest is just evidence that a variety of states of matter (in this case, hydrogen gas) can meet on the path of the beam. How at such large distances one can estimate that there is some kind of “new” (dark) matter, and even to check that it does not participate in strong interactions (and also in electromagnetic ones) – remains a mystery. To confirm such non-participation, one must know all the conditions on the path of the beam and have a strict theory of all the states encountered!

Dark energy is invented only to “explain” the supposedly accel-

erating expansion of the Universe. The expansion hypothesis itself is complete nonsense, and when it was discovered that more distant objects have a greater redshift and this dependence is non-linear, it was necessary to immediately discard the expansion hypothesis and go to the theory of light redness due to scattering and attenuation of waves. Additionally, one should take into account the energy (gravitational) frequency shift when overcoming the gravitational force from the radiating object (in the direction of the beam from more strongly attracting stars and galaxies to the less attracting Earth). It is also necessary to take into account that the path from the star to the Earth will **not be straight**, but “oscillating” depending on the density and temperature gradients and the presence of gas regions. And the greater the distance to the object, the greater will be the difference between the straight line and the path length of the beam (for example, the increasing difference between the length of the sinusoid and the straight line). This is their pseudo-extension.

No crazy terms like “equation of state for dark energy” need to be invented, since only the term “equation of state of matter” has the right to exist. And it does not make sense at all to sum up the mass of real matter and the fictional (according to erroneous calculations) masses of dark matter and dark energy (?). But the hidden mass, of course, is always there, it just has to be, because in the visible range we fix only a part of the real matter (substance).

The magnitude of the red shift is proportional to the **optical length of the path** that the light passed. The intensity of the light passing through the medium falls nonlinearly (exponentially from the real path), therefore, the estimates of the expansion of the Universe from the luminosity of supernovae  $I_a$  are incorrect.

We also note that the measurement of the microwave radiation of the Universe (the so-called “relic radiation”) by the WMAP satellite proved that our Universe is flat, i.e. according to “Occam’s razor” it was not worthwhile to invent a new entity – “the curvature of space-time”, since Euclidean geometry is quite enough. There is also no need for general relativity and a fictional cosmological constant.

We note that the conjecture of dark matter never represented any

of the experimental values it was intended for, namely the anomalous redshift of galactic stars. A numerically exact and time invariant representation of the anomalous redshift of galactic stars is achieved in [192], but via the replacement of special relativity with isorelativity.

## 2.5 Gravitational Waves

We now turn to the discussion of the so-called gravitational waves. Space and time are the categories that humanity uses to describe changing (moving) matter; this is our way of knowing the world, our organization (structure) of thinking. And space-time is a completely non-existent “object”, as well as its metric is only a mathematical abstraction in such a made-up pseudo-theory as GTR. On the other hand, gravity can have a field nature and material carriers; in this case, gravitational waves could well exist (having no relation to GTR). However, the speed of their distribution is not known in advance. The fact that they cannot be found for many decades is more likely evidence of their absence (we will discuss their “discovery” made to order by LIGO observatories later).

Note that the rates of convergence of the system of binary stars referred to in this connection cannot be determined for a short observation period (inaccuracies in the determination of all system parameters are too great). Seriously to say that you can fix the convergence of double stars (pulsars) at 2.5 inches per day can only be a false scientist (as if it even happens precisely in accordance with GTR). The timing of pulsars can only indicate heterogeneous processes on the pulsars themselves and in the propagation medium of the signal to the observer. None of these phenomena is in any way controlled and is not described by theory at 100%. Even for our closest star, the Sun, there is no theory that predicts all processes, for example, flares, 100% accurately. Also, the propagation of particles from this flash to the Earth is described very roughly. Why do astrophysicists claim about much more distant objects?! Generally speaking, a periodic change in the distance between the

objects is observed everywhere (always, except for purely circular movements), including in the Solar System. And the effect should be more noticeable from the nearest objects. This is the first.

Secondly, the calculations made by Laplace on meticulously observing the motion of the Moon showed that the speed of propagation of gravity exceeds the speed of light by many orders of magnitude, which means that the speed of propagation of gravity waves can also be much more than  $c$ .

Third, oscillations caused by non-gravitational forces in the laboratory could have a dipole (rather than quadrupole) character, i.e. the wave energy would be greater, and the attenuation less.

Fourthly, is it really proved that the formula for the energy of the waves  $E = \hbar\omega$  (or momentum  $\mathbf{p} = \hbar\mathbf{k}$ ) stops acting for supposedly massless gravity? If not, then one should expect much more noticeable results precisely from rapidly vibrating massive objects in laboratory experiments, than from mythical interactions necessarily with a (mythical) black hole.

Fifth, any changes can be discovered only in relation to something (for example, a standard). However, if the metric itself fluctuated, the dimensions of everything, including measuring instruments, would change. As a result, it would be impossible to fix any relative change (perpendicular experimental patterns of the Michelson type interferometer, which often make false conclusions, draw attention to themselves). Thus, it is impossible in principle to detect oscillations of “space-time itself”, but disturbances of a geophysical nature are easily recorded, as practice shows, i.e. GTR has nothing to do with it.

Sixth, seriously speaking about the possibility of fixing a change in the metric  $10^{-21} - 10^{-23}$  times can only notorious false scientists, because there are no values measured by humanity with such precision (any 1st year student would be sent to retake the theory of errors), and no statistics here can help here.

Thus, no space-time oscillations (according to GTR, these are supposedly gravitational waves) can in principle be detected independently of the “detector” device (gravitational antenna, Michel-

son's laser interferometer, etc.). However, what is detected – this can be explained due to real local changes inside the devices caused by changes in real physical parameters (for example, geophysical or cosmic), but not by the mythical “space-time”.

The story of the alleged discovery of gravitational waves and the receipt of the Nobel Prize for the pseudo-discovery in 100 years will be considered a disgrace, worse than the times of Giordano Bruno (as there was no threat to life for those who betrayed the Truth for money and fame). What was measured exactly in this “experiment”?

1. The existence of black holes is a hypothesis;
2. the existence of gravitational waves – a hypothesis;
3. GTR is a hypothesis rather than a theory;
4. the speed of propagation of gravity coincides with the speed of light – a hypothesis;
5. the location of the disturbance source is a hypothesis;
6. distance about 1.3 billion light years away from the “source” – a hypothesis;
7. two black holes merged – hypothesis;
8. these “holes” have the mass of 36 and 29 solar masses – are two hypotheses;
9. the mass of the new “hole” and its rotation parameter are hypotheses;
10. the amount of radiated energy is a hypothesis.

Therefore, what value was not hypothetical (settlement-fitting under the theory), but measured and controlled? None! So which of these many hypotheses could be tested in this pseudo-scientific experiment? None!

It is noteworthy that the almost simultaneous observation (2016) of such perturbation and some electromagnetic signal was interpreted as the coincidence of the speed of a gravitational wave with the speed of light. However, the arrival of gamma radiation for a few seconds after some signal in 2018 is no longer interpreted as the difference in these speeds. Here is a fitting pseudoscience!

Gravitational waves cannot be defined on a curved manifold pre-



cisely because of the curvature. Maxwell's equations can solely be defined on a flat space.

## 2.6 Conclusions to Chapter 2

The given Chapter 2 was devoted to the GRT criticism. A set of striking doubtful points from the GRT textbooks is emphasized, beginning with general concepts of the covariance, baseline physical notions, and finishing with more specific ones. The proof of the geometry invariance in a rotating coordinate system is carried out in detail. The groundlessness and inconsistency of the principle of equivalence in GRT is discussed. The inconsistency of the notion of time and its synchronization in GRT is demonstrated. The methods of time synchronization and simultaneous measurement of lengths are indicated for the most interesting special cases. The immutability of the geometry of space is demonstrated and the role of boundaries is also discussed in Chapter 2. The doubtful points are emphasized both for the methods and for numerous corollaries of GRT. The inconsistency of the notion of "black holes", of Schwarzschild's solution and many other GRT corollaries are considered in detail. The Mach principle and its possible verification are also discussed.

The ultimate conclusion of this Chapter 2 consists in the necessity of returning to classical notions of space and time and of constructing the gravitation theory on this established basis.

## Chapter 3

# Experimental foundations of the relativity theory

### 3.1 Introduction

The main part of criticism of TO from previous Chapters was founded on the so-called mental experiments. We make some trivial note to prevent the absurd question about the technical practicability and experimental accuracy of mental experiments. It is generally accepted from Galileo's time that the construction of mental experiments uses notions and principles of some theory under criticism and demonstrates their inner inconsistency. As the result, the value which can be compared with experiments is absent at all. A logical contradiction brings the final dot into the development of any theory. Nevertheless, to form the "complete picture", the consideration of the relativity theory will be continued from the experimental point of view.

Real experiments will be analyzed in this Chapter 3, and errors in the interpretation of these experiments with the relativity theory will be shown. To initiate the reflection on relativistic experiments, we consider ideas which could be "almost not conflicting" with SRT (but afterwards we step-by-step will pass to the criticism).

Introduction of Chapter 3 we begin with the question, which is

principal for the relativity theory: Is light speed constant? It would seem that, the answer to this question was allegedly given by the Michelson-Morley experiment to study the influence of the Earth movement on the speed of light, plus similar optical experiments made by Morley alone, Kennedy - Thorndike, the Viennese experiment by Joose and others [7,61,83]. We note, however, that there have been attempts to correct SRT [79,97,116], and to revive the Lorentz ether theory [1,42,64,95,108,119].

However, the term “constant” implies independence from time, spatial coordinates, light propagation direction, physical properties of the area of propagation (for example, the presence of gravity), and, finally, characteristics of the light itself. Some effort needs to be made to give an unprejudiced answer to the question: What could be determined in Michelson’s interferometer at all? We note that no speed is determined in the Michelson experiment at all, but the phase difference of the beams is measured (and we can judge speed only indirectly). Recall that light was made to traverse two mutually perpendicular directions. We note also the following: to avoid the synchronization of timepieces at different points, both light beams traveled over a closed path, namely, each of them travels in two mutually opposite directions (though beams travel in mutually perpendicular directions to each other) . Therefore, in fact, we are dealing only with some “average” speed of light for opposite directions.

Considering the foregoing, it would seem that Michelson’s result can be stipulated as follows: the average light speed of a **given frequency** in two mutually **opposite directions** in some particular reference system is independent of the motion of this system. Apparently, at least two questions arise concerning the Michelson-Morley result:

1) Is light speed constant regardless of propagation direction  $\mathbf{k}_1 = \mathbf{k}/k$ , or might it be anisotropic,  $c = c(\mathbf{k}_1)$ ? This question can be put in a broader sense: Does light speed depend on time  $t$  and spatial coordinates  $\mathbf{r}$  or not? However, from the viewpoint of SRT, such questions are beyond present theoretical and practical

possibilities, since they involve the problem of space-time structure as such. Problems of this type will not be discussed here, since their experimental verification requires the “basic system” to possess the nonelectromagnetic nature in order to measure the distances and synchronize the time pieces.

2) There arises a more practical question: Does the speed of light in a vacuum depend on the characteristics of the light itself? In particular, does there exist a dependence on frequency  $\omega$ ; i.e. does  $c = c(\omega)$ ?

The physical (philosophical) meaning of light-speed constancy is (from SRT textbooks) as follows: Let the light be capable of propagating in vacuum without any intermediate medium. Because the system of reference cannot be rigidly “tied” to the “emptiness”, it does not matter at what speed our system moves with respect to vacuum. Therefore, light speed with respect to our system must be independent of the system motion. (Although, for some reason, other particles can move in vacuum with very different velocities!) However, the following questions arise: 1) Do vacuum properties change when particles (photons) are brought into the vacuum? 2) What is the mechanism for propagation of electromagnetic oscillations in vacuum? Some particular hypotheses answering these questions will be presented in Appendixes B and C.

What actually could be determined in existing experiments will be analyzed in detail in the given Chapter 3. As a result, a detailed criticism will be presented against the relativistic interpretation of a number of well-known experiments and observational data, which are inadequately attributed in favor of SRT and GRT (in order not to irritate relativists, we will not consider those experiments that clearly contradict the theory of relativity and are usually ignored by RT apologists). The single, seemingly “working part” of SRT – relativistic dynamics – will be considered in detail in the next Chapter 4.

SRT is known to rest upon two basic postulates: (1) light-speed constancy, and (2) the principle of relativity, which is extrapolated to electromagnetic phenomena. As one of the main proofs of the

validity for the principle of light-speed constancy, they consider the negative results of experiments on observing the ether wind.

Time synchronization according to Einstein's method introduces artificial limitations even into the ideas of experiments. Obviously, by virtue of the reversibility of relative motion ( $-\mathbf{v} + \mathbf{v} = 0$ ), only an odd-powers effect can exist for the velocity dependence of light speed. However, the Michelson - Morley experiments, and some other ones, try to determine light speed as a mean velocity for two mutually opposite directions (for a closed path). Therefore, a sole classical linear dependence on the velocity of motion of a system is mutually excluded. Thus, any similar approach already substitutes the postulate of constancy of light speed, which should be verified experimentally.

Below we will analyze what should be obtained in the experiments of Michelson-Morley and of other researchers from the viewpoint of empty space (more precisely, from Galileo's relativity principle). Note that it is impossible to presume in advance anything about the motion of the Earth. For example, at Galileo's time, similar experiments would prove that the Earth was at rest. Generally speaking, before using a "device", the latter must be tested and graduated under laboratory conditions – we must know what can be measured by it? But the present situation was as in the anecdote:

- "Test device, Pete!"
- "Three!"
- "What means "three"?"
- "But ... what is a device like?"

Imagine as if someone had a "theory" that there should be a constant wind along the terrestrial parallels of the order of 400 m/s due to the rotation of the Earth around own axis. Measuring it with weather vanes with rotators, it would be obtained that the wind is permanently varying within the broad limits both in the direction and in the value depending on time and place. The "conclusion" would be made from this fact that the atmosphere is absent at the Earth at all.

Since the book is specifically devoted to the criticism of the rela-

tivity theory, we will primarily broach the conventional modern relativistic concepts, though some ether concepts will briefly be outlined also.

### **The Michelson - Morley experiment**

Before presenting the correct approach to the analysis of this experiment (which will be done at the very end of the current paragraph), it is simply necessary, for understanding, to discuss a number of accompanying subtleties and possible interpretations of the theory of the experiment and its results. We will discuss the ether concept below, but for now we will focus on the principle of relativity in a vacuum, since for all the paradoxes of STR and the results of this book it does not matter whether we have a vacuum or an ether. Since textbooks impose on us a greatly simplified and somewhat distorted theory of the operation of the Michelson interferometer, and from the approximate results of this experiment they make global conclusions, then for the sake of bait we will play along with the textbooks, temporarily believe in such an idealized instrument and consider the results that could be expected from the point of view of **Galileo's principle of relativity**. It is known that light manifests itself in various phenomena either as a particle or as a wave (the phrase about corpuscular-wave dualism has no relation to the issue under consideration). At first, let us suppose light to possess a corpuscular nature. Then the Michelson - Morley interferometer model can be represented as two mutually perpendicular arms with one ideal reflector in the center of the setup and two reflectors at the ends of the arms (Fig. 3.1). Let the two particles moving parallel to each other at velocity  $\mathbf{v}_1$  (relative to the "universal reference system") fall into the given setup, which, in its turn moves at velocity  $\mathbf{V}$  with speed  $V < v_1$  (relative to the same reference system). Then at point  $O_1$  the speed of particles relative to the setup will be  $v_1 - V$ . After reflection at the setup center, particle 1 will move in the perpendicular direction at the same speed  $v_1 - V$  relative to the setup. The particles will be reflected from the ends of the arms

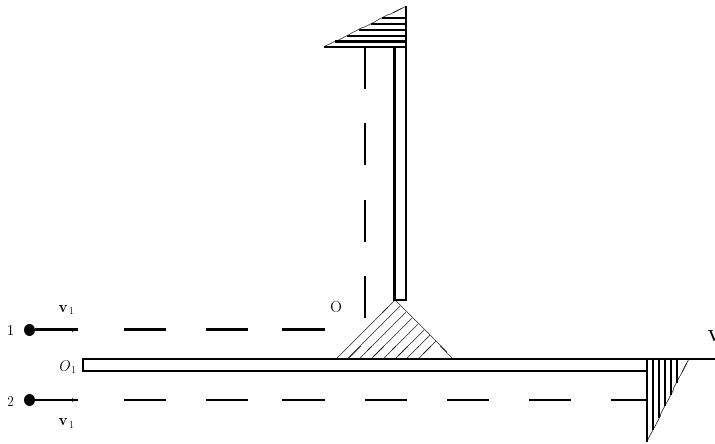

Figure 3.1: Corpuscular model of Michelson - Morley experiment.

simultaneously. Likewise, they will reach simultaneously both point  $O$  and point  $O_1$ . No difference in speeds of these two particles for two mutually perpendicular directions will be observed, regardless of velocities  $v_1$  and  $V$ . Thus, if the light is supposed to be a flow of particles, then the experiments by Michelson - Morley (by Kennedy - Thorndike, Tomachek, Bonch-Bruevich and Molchanov and others) could not give any positive result. And this would be from the point of view of any principle of relativity, including Galileo's.

Let us now suppose light possesses a wave nature. In this case, light speed can only depend on the properties of the propagation medium (ether or physical vacuum; relativists believe in emptiness) and intrinsic characteristics of the propagating light itself (frequency, amplitude). If light is a wave, then only the light frequency changes with source velocity. So, for given  $\omega$ , the light speed  $c(\omega)$  does not depend on the source velocity. Here we have in mind the following situation: the light waves of the same frequency are identical to each other; and if we perceive the light of frequency  $\omega$ , then it does not matter, whether it was emitted by a source at the same frequency, or if it was emitted at another frequency  $\omega_1$ , and due to

source motion the frequency changed:  $\omega_1 \rightarrow \omega$  (the Doppler effect). In both cases, the measured value of  $c(\omega)$  is the same. Now we return to the Michelson - Morley experiment and similar ones by other researchers. Since the incident light, the light passed through the thin plate, and the light reflected from the mirrors, all have the same frequency in the same observation system, the light speed  $c(\omega)$  remained constant for the two mutually perpendicular directions, and the experiments could not detect anything. Tauson's experiment with two similar lasers could not discover anything either, because in converging the beams to a single pattern (in the same direction), the frequencies become equal, and no regular beatings are observed. Thus, the attempt to find changes in light speed from the experiments with the same fixed frequency is wrong in itself. The only dependence we may try to discover is  $c(\omega)$ : all other dependences can enter only indirectly, through the Doppler effect. Thus, if we consider light as a wave, then the Michelson-Morley (Kennedy-Thorndike, Tomashek, Bonch-Bruevich and Molchanov and others) experiments again could not give any positive result. And this would be from the point of view of any principle of relativity, including Galileo's.

So, if relativists believe in empty space and the strictly zero result of Michelson's experiment, then Galileo's principle of relativity is quite sufficient to explain it (and there is no need to invent new entities).

For methodical purposes we shall consider some plausible errors from textbooks. When researchers proceed from the "classical viewpoint" (i.e. the hypothesis of motionless, non-involved ether), they often calculate the difference in times of beams propagation in an interferometer using a strange scheme [35], in which the reflection law does not "work": the angle of reflection does not equal the angle of incidence (Fig. 3.2). This "fact" contradicts experiments. In such a circumstance, it is at minimum necessary to explain the mechanism of such a deviation, and to determine its effect on the experiment (it could be made in the assumption of classical laws for the addition of light velocity and the velocity of an interferometer's mirror).



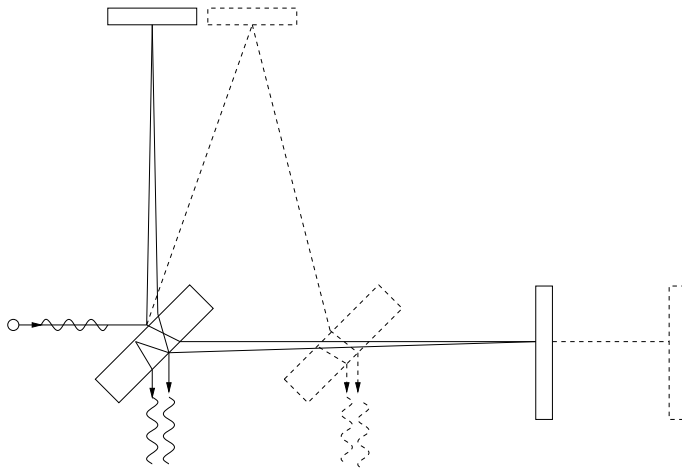

Figure 3.2: Scheme of the interferometer.

It is not clear either how we can guess the angle ensuring the interference of one and the same beam. Actually, since all data are registered only by the observer moving together with the interferometer, the experiment must be analyzed only from the viewpoint of this observer as well [50].

If we accept a hypothesis that ether exists, then light speed depends on the properties of this medium (by analogy to sound). It is obvious then that light velocity cannot be added with source velocity (the roar from a supersonic aircraft propagates at the velocity fixed by the medium, and, as a result, the aircraft outstrips the sound). It is also obvious that, since light interacts with both matter (it scatters or absorbs) and ether (it propagates), then some interaction between ether and matter should also be observed. But in the Michelson - Morley experiment, something improbable was assumed; namely, a rigid “binding” of light to ether, along with absolutely no interaction of ether with bodies, (i.e. no ether entrainment by the Earth or by the interferometer), i.e. the case of a stationary ether was imposed. Of course, the theory would be complicated in the

case of partial entrainment of the ether (for some local experiments an ether entrainment can practically be complete inside the narrow boundary layer). However, this fact in no way disproves the ether hypothesis (relativists, on the other hand, suggest acting like in a joke about a drunkard under a street lamp: look not where you can find, but where it is easier to look).

We will not discuss the results of those experiments in which, instead of an interference pattern, the intensity of the halves was compared by shading (even if it is claimed that the sensitivity is higher - this is the same as comparing the average temperatures in two hospitals, including morgues), but we will make some comments concerning the original idea of the interference experiment from the point of view of etheric concepts. Note that the Fresnel entrainment coefficient can always be slightly corrected in such a manner, that the experiments of both 1-st and 2-nd order be confirmed to a practical accuracy. For the sake of justice one should note that the Michelson experiment and its analogs (in spite of the disputes concerning the instrument structure and the theory) have always confidently, with allowance for possible errors, given a nonzero velocity of the ether wind [94,95]. Marinov [90,91] and Silvertooth [115] have found a correct velocity relative to a relic radiation. Only at instrument screening with a metal casing the result occurred to be close to zero one. Not accepting the ether theory unconditionally, nevertheless, we recall for the sake of objectivity, that all instruments are vacuumed now (i.e. made a locally closed system). And, for example, the local speed of sound in airplane's saloon will remain constant (independent on the wind outside) even at supersonic motion of an airplane. The ether point of view does not contradict the obtained results: Fresnel's entrainment for metal bodies is complete (Hertz's electrodynamics is valid for metals), and, hence, the ether is resting locally inside the metal casing relative to an instrument, and search for the ether wind inside is senseless. Yet another moment is usually hidden by relativists. The entire set of experimental data on optics testifies to the correctness of Huygens' principle: each point reached by a wave is a source of secondary waves. Even in the absence of

metal casing, the presence of a thin glass plate (or air in the original experiments) leads to light reradiation from these local resting elements. As the result, in the ether concept the really measured velocity must be wittingly less than the velocity of orbital motion of the Earth. And why should the speed of the ether wind coincide with the orbital speed? The etheric concept assumes that all substances consist of ether (including the Earth), and the Earth does not fly through a motionless ether, but rather the etheric vortex movements are responsible for the rotation of the Earth around its axis and the Sun (this is why the slowdown of the planets' motion is practically unnoticeable even over millennia). Consequently, the speed of the ether wind may be much less than the orbital speed of the Earth. And there is no need to bring in the magnitude of aberration to supposedly refute such an idea: it will remain the same, since only **change in the apparent direction to the source at opposite points of the orbit** is registered.

Another mistake is when, instead of a wave description of interference, we are given a description of the motion of a boat (a solid object) that persistently (transitionally) rows in a chosen direction (i.e., mechanical work is performed). The next plausible mistake is the description of the experiment as if it determines the speed of the Earth. The Michelson interferometer is not capable of measuring speed. Although the interference pattern is formed as a result of the phase difference of the incoming rays, the interferometer does not even measure the phase difference: it is capable of detecting only a change in this very phase difference. And then the interpretations begin – what could cause this change.

Note that if the thickness of the translucent mirror (and, accordingly, the compensating plate) were strictly equal to zero, then the result of the Michelson experiment would also be strictly equal to zero. The fact is that in such a simplified scheme, the influence of the longitudinal (along the selected arm of the interferometer) velocity component on the phase of the wave along this arm is strictly zeroed due to the Doppler effect [132]. This happens because the source and receiver of the waves are in the same moving system

(the frequency must be multiplied by the same factor when exiting the source, the frequency must be divided by the same factor when entering the receiver). On the other hand, the influence of the perpendicular (to the same arm) velocity component on the phase of the wave along the perpendicular arm is also zeroed due to the aberration effect (the movement of the beam back after reflection compensates for the change caused by the movement of the beam before reflection [132]). If the compensating plate were able to coincide in all cases with the influence of the translucent mirror plate, then the total effect for the reasons stated would also be strictly zero. However, this is not the case.

Let us recall that in one experiment it is possible to check only one dependence, and only on condition that everything else is already determined. If you experimentally check some interrelation between parameters, then the values of all these parameters and all the experimental conditions must be determined independently (according to previously confirmed experiments and calibrated devices). Let us now mentally return to those times and take an unbiased look at the structure and capabilities of the interferometer itself. What objections do relativists not make to the experiments of Michelson-Morley and, especially, Miller! Let us play along with the relativists! Magnetostriction, you say? Of course! And there is also electrostriction, temperature inhomogeneities of the interferometer arms and the medium, radiometric forces, gravitational distortions of the shape of the device and the path of the beam, non-inertiality. And what was known about the speed of light  $c$ ? Nothing: does it add up or not to the source velocity, does it add up or not to the receiver velocity, how does it behave in the physical fields of the Earth, what is its most accurate value? What was known about the expected velocity  $v$ ? Nothing is known exactly either. What is known about the lengths of the interferometer arms? Nothing is known exactly either: they are not measured with an accuracy of fractions of the light wavelength, and if the lengths can be shortened during movement, then how can we check the equality of the perpendicular arms at a specific angle of rotation? In the

presence of gravitational and other fields on a non-inertial Earth (the fictitious relativistic geometry of the fictitious space must be curved), we cannot in any way check the exact perpendicularity of the interferometer arms, the parallelism and perpendicularity of the mirrors. Obviously, such an experiment cannot provide any precise quantitative confirmation (there are too many uncertainties – it is not known what is being checked and by what). This is not a crucial experiment, and global conclusions cannot be drawn from it. And yet, even from such a flawed experiment, something can be learned.

Let us now try to formulate honestly, without interpretations, what exactly happened in such experiments (and not what relativists are trying hard to impose on us, leading our eyes away from reality).

I. It was necessary to tweak the micrometer screw to catch the interference pattern (sometimes the pattern disappeared right during the measurement, then the screw was tweaked again).

II. The period of the interference pattern change often did not coincide with  $90^\circ$  or  $180^\circ$ . Moreover, a linear trend was often observed for the average fringe shift at such periods!

III. There was no linear dependence of the fringe shift amplitude on the lengthening of the beam path using mirrors, i.e. the qualitatively visible pattern of changes changed little (however, relativists, due to the false theory of this experiment, make an artificial conclusion about the increase in the accuracy of the zero result).

IV. The behavior of the interference pattern changed (sometimes noticeably) when the interferometer was closed or filled with a different gas.

Based on all the comments made in this section, we can now formulate what needs to be taken into account in order to construct a correct theory of the Michelson interferometer (and from such experiments quantitative results could be extracted).

1. It is known that interference is possible only for rays from one source (physicists could not even achieve interference from two identical lasers for several decades). Therefore, the source must be point and monochromatic (otherwise, for an extended colored source, instead of moving stripes, the picture may “breathe”). Thus,

in the correct theory **two rays must originate from one point** (clarification below in point 3.).

2. **These same two rays must arrive at one fixed point** on the retina of the eye or the matrix of a camera or video camera (they determine, for example, whether the intensity maximum or minimum is at this point). Several pairs of rays can arrive at one point! (why – clarification below in point 3.)

3. The description of the ray path imposed on us is distorted (it's like telling about a paper airplane instead of studying a supersonic airplane). Textbooks mistakenly depict the matter as if there is one single ray along the first arm of the interferometer (i.e., at  $\alpha = 0$ ) and it is divided into two rays on a translucent plate. However, for a specific interferometer (i.e., for all the not precisely determined, but **fixed** dimensions of the device and the angles of the mirrors and plates) at an arbitrary angle of rotation  $\varphi$  this is simply impossible. On the contrary, our task is to find such rays that satisfy points 1. and 2.? It is necessary to solve the inverse problem: calculate at what different angles  $\alpha_1(\varphi) \neq 0$  and  $\alpha_2(\varphi) \neq 0$  two rays must start from a point source (note: these angles change differently when the interferometer is rotated) in order to always hit the same fixed point of the video camera matrix. We are interested in the change in the phase difference of the rays arriving at this point depending on the rotation angle  $\varphi$ . This means that we need to reconstruct the entire path traveled for each ray. The entire path is divided into sections by obvious obstacles (surfaces that lead to reflection and refraction – mirrors and plates). Along each such section  $i$ , these rays move at different angles, therefore, the rays have different frequencies:  $\omega_1^i(\varphi), \omega_2^i(\varphi)$ . For each ray there will be a different dragging along by the medium (and ether); inside the plates, it is necessary to take into account the frequency dispersion:  $n[\omega_1(\varphi)], n[\omega_2(\varphi)]$ . As a result of calculations for the phase difference, we obtain a too cumbersome transcendental equation, which can only be solved numerically.

The theoretical result will be as follows. As already mentioned, at zero thickness of all plates there is no shift of fringes. With increasing thickness of plates the amplitude of shift changes quasi-

periodically; with increasing value of refractive index the magnitude of effect also changes quasi-periodically. In general case the shift is a small fraction of the so-called quadratic effect expected by relativists. Lengthening of path does not lead to increase of accuracy, but only to small quasi-periodic changes of shift value. In order to make quantitative conclusions from real experiment it is necessary to determine as accurately as possible all mentioned characteristics of the device.

Thus, the Michelson-Morley experiment does not testify in favor of the constancy of the speed of light and does not refute any classical principles, rather the opposite: it once again confirms the Fresnel entrainment hypothesis and indirectly testifies in favor of the presence of some movement of the ether.

### **Aberration, the Fizeau experiment and other experiments**

So, which experiments cannot be explained in any way other than invoking SRT? We begin with some subsidiary remarks. We shall not discuss in detail the issues of quantum electrodynamics, because its predictive accuracy depends only slightly on the accuracy:  $(\Delta c/c) \sim 10^{-8}$  (this is with motion of the receiver; and light speed can remain constant with motion of the source, for example, by analogy with the sound speed), but nobody even made an attempt to consider light speed to be not a constant.

The stellar aberration phenomenon is fairly explained by the classical physics [23] and is determined by the following two principal facts:

- (1) by changes (throughout an year) of the velocity of the observation system, basically by the orbital rotation of the Earth (this absolute state does not depend on the rectilinear motion of inertial systems and on the presence of ether or medium), and
- (2) by the rectilinear propagation of light beams between the source and the receiver for inertial systems (it is a result of the light particle inertia for the corpuscular theory, or it is a result of Huygens'

principle for the wave theory).

Recall once again that upon “entrance” into our measuring device the light has a fixed direction and frequency (the prehistory of the process is not important: is it the motion of a source, of a “medium”, of a receiver), and it is this “particular light”, with which all measurements are carried out. The Fizeau experiment is not a critical experiment, since it allows to write light speed in a medium as

$$u = \frac{c(\omega)}{n} \pm v\left(1 - \frac{1}{n^2}\right),$$

and the measurement were carried out for a particular fixed frequency  $\omega$ , i.e.  $u(\omega_1)$  and  $u(\omega_2)$  have not been compared, which is impossible to be done in the Fizeau experiment.

The attraction of a lifetime of muons for proving the SRT is the pure speculation. The modern mankind cannot create two inertial systems moving relative each other with relativistic velocities. And it is not worth to mask quite a different reality in imitation of the claimed “experiment”. The lifetime of unstable particles must depend on the conditions of their formation (even a stable nucleus can become excited or unstable, or, on the opposite, the recombination can take place, etc.); and the conditions of formation of muons at the altitude of 20 – 30 *km* upon collision of high-energy cosmic rays with nitrogen or oxygen atoms differ from the conditions of their formation and confinement in the laboratory. To say nothing of the fact that even velocities of muons, their accelerations and intensities of flows did not determined at different altitudes. Measurements, which made in accelerators, most likely testify to influence of accelerations and fields on the concrete decay process of the concrete particles (this is also an indicator of the double standards of relativists: alternately either they are ready to redirect you to GRT for the slightest non-inertiality, or they “innocently” close their eyes to the huge accelerations on accelerators and the inapplicability of the SRT ideology of inertial systems by itself to such pseudo-explanations when they are aimed at protecting SRT). The “muon proof” was appeared in all SRT-textbooks starting from



1935, but some later it was discovered that 1) muons origin at any altitudes, and 2) their penetrating ability considerably increases with enhancement of energy. Nevertheless, the relativistic pseudo-proof has not been excluded from the textbooks, and they continue to fool the heads of students (to the question of scientific ethics).

### The Ritz hypothesis

For the sake of fairness, we note that even the Ritz ballistic hypothesis [174] (in essence, it is the classical law of addition of velocities for corpuscles) could not so easily be disproved at the beginning of 20th century. We shall present briefly the derivation from [29] and make some comments. The time for a signal to arrive from a satellite of a central star at distance  $L$  is, upon entering the shadow  $t_1 = L/(c-v)$ , and upon exiting from the shadow  $t_2 = \frac{T}{2} + L/(c+v)$ , where  $T$  is the orbit period. We suppose for a noticeable effect (when the binary system will be seen as a ternary) that  $t_1 = t_2$ , which leads to  $L = T(c^2 - v^2)/(4v)$ . For the diameter of orbit we have  $D = Tv/\pi$ . If  $\alpha$  is the observation angle, then  $\alpha \approx \tan \alpha \approx D/L$ , and, since  $v \ll c$ , we have  $\alpha = 4v^2/(\pi c^2)$ . The real velocities of observed satellites are  $v \ll 350$  km/s. As a result, for observation of a similar effect, we must have  $\alpha \ll 2 \times 10^{-6}$  radians (which is beyond the accuracy of modern telescopes).

Of course, this conclusion is rather rough. In the expression for  $t_2$ , instead of  $\frac{T}{2}$  one must write  $Tx$ , where  $x$  is the fraction of a period, when the satellite is in shadow; generally  $x \ll \frac{1}{2}$ , which increases the limiting accuracy of  $\alpha$ . Besides, very short time intervals can be recorded now by means of photography (if the exposure allows this), i.e. one may write  $t_2 - t_1 = \frac{T}{2} + y$ , where  $y \ll T$ , which ever more increases the limiting accuracy.

However, some remarks can be made for defense as well. Namely: (1) The study of  $t_2 \geq t_1$  is non-productive, since all observed eclipses will be periodic, and we can not verify in any way, whether we really observe a threefold (or fourfold, etc.) system, or this is only a semblance.

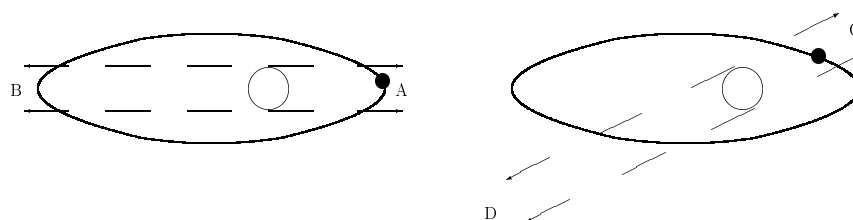

Figure 3.3: Estimation of a shadow region.

(2) During the orbital motion of a satellite, the time of signal arrival to the observation point changes smoothly (the real object – a satellite – does not coincide with its visible image), which distorts the determination of a real orbital motion and a value of  $x$ .

(3) Since the light passes through the inhomogeneous medium (the atmosphere, as well as the near-Earth space), the phenomena of scintillation and dispersion can take place. In order to lower their negative effect, the full (rather than partial) eclipses should be observed and, preferably, from the Earth artificial satellites.

(4) Because only the projection of the orbital plane will be accessible for us, we cannot, in the general case, estimate the value  $x$  of the region of shadow (Fig. 3.3). The time of motion in a shadow will be different depending on the direction to the observer (to the Earth). Hence, the objects with symmetric orientation are required, and the accuracy of determination of “arms” for the orbit projection and of the size of both bodies imposes limitations on the (calculated) accuracy of determination of signals arrival times.

(5) We have already mentioned above, that the abstract speed of light does not exist, but specific values  $c(\omega_1[v])$  and  $c(\omega_2[-v])$  will be observed. Therefore, the accuracy of determination of frequencies  $(\Delta\omega/\omega_0)$  imposes limitations on the theoretically calculated accuracy  $(\Delta c/c_0)$  and, accordingly, on  $(\Delta t/t)$ .

The most principal comment is as follows:

(6) The light of some frequency  $\omega_0$  is emitted, not by the object as a whole moving at velocity  $\mathbf{v}$ , but rather by the particles moving

chaotically within the object with thermal velocities. Therefore, it is impossible to determine the delay of calculated time depending on the velocity of the object as a whole by using any characteristic (in microscales) frequencies (radiation lines). Only if the graph of satellite spectral intensity  $I(\omega)$  possesses some particular characteristic form (for example, having a maximum  $I_{max}$  at frequency  $\omega_1$ ), and if  $I(\omega)$  differs identifiable from the graph of star spectral intensity (for example, in shape), then the observation of changes in spectral intensity  $I(\omega, t)$  at this variable frequency  $\omega_1(t)$  can prove or disprove the Ritz ballistic hypothesis.

As far as the author knows, no such detailed analysis of the astronomical data was carried out. It should be further mentioned that the Ritz hypothesis predicts for binary systems not only a phase modulation of the signal received, but an amplitude one as well (as the result of the varying speed of light propagation, in a fixed space point there occur a pulsation of an intensity due to superposition of light which was emitted at different time instants). As this takes place, the relative intensity of pulsation increases with the distance to the binary system. The frequency of pulsations also increases (to some limits). Some authors [29] believe that the “existence” of quasars and pulsars is one of proofs of the Ritz hypothesis. Really, the smallness of their pulsation period (sometimes less than one second) testifies to the compactness of these objects, but the emitted radiant power (taking into account their remoteness) testifies against the first assumption. And either we must thoroughly test the Ritz hypothesis, or it remains to believe in modern fantastical (non-verifiable) versions. And complications with the processing of radar observations of the Venus compel to meditate on the possibility for the inertial properties of light to exist.

It is necessary to make a few remarks about the experiment with synchrotron radiation [167], where it is claimed that it refutes the ballistic theory.

- 1) velocities are not directly measured at all;
- 2) for some reason, the velocity and path of electrons from one quadrant to the other are considered known (and does quantum

mechanics agree with this?);

3) in the second case, the passage of a thin plate and reflection from a mirror are used (what is the effect on accuracy?);

4) the paths chosen are strangely asymmetrical:  $IL = 580$  cm, II  $L_2 + L_3 = 205 + 210 = 415$  cm;

5) the electron velocity almost does not differ from  $c$ , and cannot be identified with the accuracy required by the experiment;

6) in fact, experiment is not talking about the ballistic hypothesis at all, but rather about the influence of the re-emission of atoms;

7) in both cases, a harbinger is detected – the front;

8) the reaction time of photomultipliers to different photons and the effect of the asymmetry of the experiment are unknown;

9) also for the second experiment - an approximate combination of a mirror and a prism;

10) there is no direct comparison of the only possible dependence of  $c(\omega_1)$  and  $c(\omega_2)$ .

Thus, this experiment can hardly be interpreted with unambiguity as a refutation of the Ritz hypothesis.

However, the defence or development of Ritz's hypothesis is not a goal of this work. You can learn more about the very interesting ideas of V. Ritz, including his ballistic hypothesis, in [203].

### The Sagnac experiment

The Sagnac experiment was a direct proof of the inequality  $c \neq \text{constant}$  (and indirect evidence for the classic law of addition of velocities). Recall that four mirrors (more exactly three mirrors  $B$  and one plate  $H$  – see Fig. 3.4) were installed along the periphery of a disc rotating at angular rate  $\Omega$ . A light beam was divided (by the plate  $H$ ) into two beams, and one beam traveled counterclockwise (in the direction of rotation) while the other traveled clockwise. An interference was observed at meeting of these beams. The fringe shift (as a result of the difference in times of propagation of light beams) had magnitude:  $\Delta z = 8\Omega r^2/(c\lambda)$ . It is obvious that the non-inertial character of the system rotating at  $\Omega$  is of no concern:

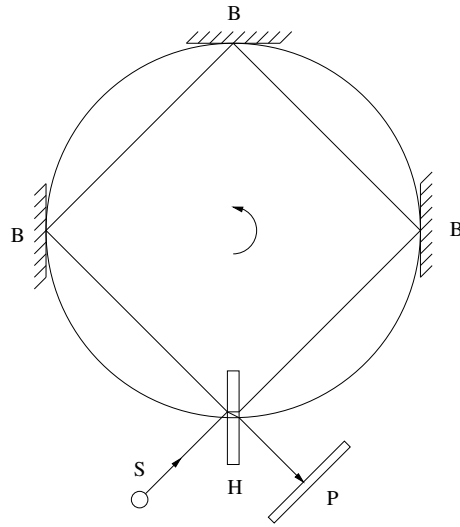

Figure 3.4: The Sagnac experiment.

nobody saw a curved light beam in vacuum; light travels between two reflections rectilinearly. Nevertheless, we consider the following mental experiment: Imagine that the disc radius tends to infinity  $r \rightarrow \infty$ , but the value  $\Omega r = v$  remains constant. Then we have  $\Omega \rightarrow 0$ . Therefore, the value of the acceleration  $\Omega^2 r$  tends to zero. Let us choose a radius  $r$  such that the acceleration is much less than any pre-specified value (the existing experimental accuracy, for example). Nobody can distinguish this “near-inertial” system from a true inertial system. If the number of equidistant mirrors is also increased ( $N \rightarrow \infty$ ), then the straight line (of light beams) between mirrors approaches the disc circle. As a result the fringe shift can be expressed as  $\Delta z = \alpha L v / c$ , where  $\alpha$  is a constant for a given ( $\lambda$ ) light, and  $L$  is the circumference. Because of the obvious symmetry of the experiment, the effect is additive in  $L$ , and its value can be related per the unit length. A “cumulative” effect of acceleration can be made less than any pre-specified value for a

given straightline region. Thus, we have for the magnitude of the fringe shift:  $\Delta z \sim v/c$  (some variations in  $\Omega$  produce appropriate variations in  $v$ , since  $v = \Omega r$  is a finite value). Therefore, the time of signal propagation linearly depends on the velocity of the motion of the system, that is,  $c \neq \text{constant}$ .

### **Say a good word for the “poor ether”**

Now we make an auxiliary remark concerning the ether. Frankly speaking, the inventing, apart from the “absolute emptiness” (not possessing physical properties), of the other concepts of “physical vacuum”-type (possessing physical properties) is unfair with respect to many previous researchers (plagiarism), since for similar concepts there exists already a special term – “the ether”. Only for the ether the impossible mission was stated: to explain all experiments on a simple and clear model or “to go out from the scene”. The further development of physics introduced another practice (remember the dualism of light, the quantum mechanics, etc.): the contradictory properties of physical objects and phenomena have become to be simply postulated as a fact without explanation and without a real visual model. For example, there exists a two-component liquid model for describing the contradictory properties of superfluid helium (the flow without viscosity through a capillary and the presence of viscosity at rotation). The reality is far from the model, but the model really works (it is useful). More that impossible was demanded by the relativists only from the theory of the ether. Though, in fact, for all ether models declared unreal by relativists there were analogies in the nature (but what can be greater expected from the model?). For example, there is nothing surprising in the fact that the speed of light can remain the same as the ether density changes: the speed of sound in air for  $T = \text{constant}$  does not depend on the air density as well. There is nothing unnatural also in the fact that the ether density can essentially (60000 times only) increase near the Earth surface as compared to the open space (the density of the atmosphere grows many orders of magnitude greater). The Stokes

model is a model without the atmosphere. The mathematical difficulties of the model (the supposition on a vortex-free incompressible motion) are pure at anything here: the real (nature describing) solution can occur to be close to that found by Stokes (simply it is mathematically more difficult to find the true rigorous solution of nonlinear partial differential equations without simplifications). In fairness, we note that now there exist quite developed concepts of the ether (for example, [1,8]) and a well-developed mathematical approach using ether representations [142].

Now we proceed to more specific issues and make brief comments to some well-known experiments. The aberration in the empty space without SRT was analyzed above from the viewpoint of both corpuscular and wave theory. The result will be the same from the viewpoint of the motionless ether theory as well. The full ether entrainment by a medium is not clear in the case, if the medium density gradually decreases (for example, in gases). By this reason nobody (except the relativists) has seriously discussed the full ether-entrainment hypothesis. Even in the case if ether were fully entrained by solid and liquid bodies, analysis could not be simple. In this case it is necessary to develop a theory of a transition layer between mediums and a theory of boundary ether layer for gases depending on gas density (for example, in Michelson's experiment, we could not talk about  $30 \text{ km / s}$  – the orbital velocity of the Earth itself). However, physics chose the other way, and it was still Fresnel, who introduced the coefficient indicating, that only partial entrainment of ether can be supposed in the optically transparent media. It does not virtually (to achieved accuracy) change the aberration in filling a tube with water; this had been shown by Fresnel himself. (Note that if the observation is non-vertical, it is necessary to take into account the angle of refraction of beams in filling media, but, generally speaking, all similar questions are ascribed not to the theory of aberration but to the theory of refraction.) The only case, where it is lawful to discuss the full ether entrainment hypothesis, is the case of optically opaque media (metals). Maybe it was Hertz, who intuitively felt this situation, when he refused from the very

beginning to consider the optical phenomena from the viewpoint of his electrodynamics (by this reason the application of his theory by relativists with discrediting purposes for dielectrics is invalid).

Trouton and Noble's experiment does not contradict Galileo's principle of relativity for the empty space. Generally speaking, all experiments with dielectrics do not contradict Galileo's principle of relativity, since the light (or the field) passes a part of its path in the emptiness between atoms and the other part of its path – when the light is absorbed and re-emitted by atoms. For the theory of partially entrained ether (if there is no metal screening) the Fresnel entrainment coefficient can always be defined with the practical accuracy which is verified in both the experiments of first and second orders (but frequently the precision turns out small and really it must be introduced some “fitting” coefficients). The Rowland experiment has actually proved that, from the ether theory viewpoint, the ether is fully entrained by a metal, and from the viewpoint of Galileo's principle of relativity he proved the moving charges equivalence to the current. Roentgen, Eichenwald and Wilson have actually obtained in their experiments the Fresnel coefficient of entrainment in dielectrics.

### **The Kennedy-Thorndike experiment**

The only difference between Kennedy-Thorndike's interferometer and Michelson's interferometer is the following: lengths of perpendicular arms were made evidently different in Kennedy-Thorndike's interferometer. However, for the interference pattern, it is only important the difference in the path of the rays in relation to the wavelength of the light used (fraction of the wavelength). Besides, an interferometer arms (for example, Michelson's interferometer) are always measured with an accuracy which is less, than the wavelength of used light. Therefore, contrary to the judgement of [38], the Kennedy-Thorndike experiment does not principally differ in anything from the Michelson-Morley experiment. As a result, all remarks to the Michelson-Morley experiment, which are indicated



previously, will be remained common for both these experiments.

If one proceeds from the experiment goals (on detecting the effect of the interferometer system motion on the speed of light), then author's estimate of  $v \leq 15$  km/s is more adequate, than that stated in the textbooks, though it is incorrect too (see below). The great stability in temperature, beginning with some limit, does not matter, because at any  $T = \text{constant}$  ( $T \neq 0$ ) always exist temperature fluctuations and oscillations of a crystal lattice of the base. Of most importance is the fact, that various speeds of light  $c(\omega)$  (the only possible distinction – see above) have not been compared for various frequencies  $\omega$ , which was impossible to do in a similar experiment. Besides, for the empty space all classical considerations for inertial systems remain valid; that is, Galileo's principle of relativity [48] is met in this case. The general note about metallic screening for the ether model is applicable to this experiment as well. Thus, all listed experiments have no relation even to detecting the motion of the Earth.

### The Ivese-Stilwell experiment

Now we shall pass to the Ivese-Stilwell experiment. Note that Ivese himself was a SRT opponent and explained the experiment from the ether theory viewpoint (which means that such an interpretation is also possible). Generally, it is characteristic of SRT to “put” everything into a personal “pile” (probably, in order to look more solid) or to “tie up” SRT with all theories (even not completely verified), pretending that if SRT “sinks”, then “all science will also sink”.

Generally speaking, unlike the elementary theory of the Doppler effect, determination of a frequency dependence in some arbitrary configuration is a prerogative of experiments (and an implication of an additional hypothesis for time here is rather doubtful). Actually, the Ivese-Stilwell experiments, even in the ideal case (with neglecting real features of a process) would determine not the transversal Doppler effect, but the Doppler effect for two directions close to  $0^\circ$

and  $180^\circ$ , i.e. the effects close to longitudinal ones. These experiments are indirect, since the value of a relativistic correction is a calculated quantity (which is compared, in addition, from various regions, which results in the additional asymmetry). The experiments [22] have shown essential systematic deviations from the relativistic expression (up to  $60 \pm 10\%$ ). Therefore, the effect can be determined not so much by the Doppler expression, as by the feature of reactions in beams. In addition to mentioning the other alternative experimental data [22,120], we shall give some criticism of the considered experiment. Relativists describe the experiment in such a manner, as if the transversal Doppler effect is perceived from one point of an installation at some certain time instant (the time of passage through the median perpendicular). Actually, the perceived signal is an integral sum from various regions of radiation for various time, and these regions are, in addition, not perpendicular to the motion (where, for example, the aberration has gone?). That is, the studied effect represents some “composite mean value” between two longitudinal Doppler effects.

For the Doppler effect in SRT, relativists make another forgery: they consider point light flashes (that is, **spherical waves!**), but the results are compared with the classical Doppler effect for *plane-parallel waves*. For plane-parallel waves, it is obvious that there exists no transverse Doppler effect (and relativists should not puff out their cheeks here). But if someone does not understand the difference between spherical and plane-parallel waves, then, apparently, he does not understand either physics or mathematics (for example, at the level of the 8th grade of a Soviet high school, one can strictly find the exact solution to the following problem: oscillating up and down the float excites circular waves on the water; how many wave maxima per unit time will be recorded by an observer moving along a certain line above the surface of the water?). Some twists and turns associated with the history of the discovery of the Doppler formula for spherical waves (and the classical transverse Doppler effect) by different people and opposition to this discovery are described in the textbook [132] and in [204]. Unlike

these works, we will not investigate the wavelength, but we will look for a more familiar characteristic – a change in frequency when the source and/or receiver move.

Let us first consider spherical waves excited **by a moving point source** in a medium (for example, it can be sound or circles on water). Let the signal receiver at rest be at the point  $R$  (Fig. 3.5). If the source were at rest at the point  $O$  all the time, then the direction of signal propagation would be represented by the  $OR$  line (the wavelength can be determined by dividing the distance  $|OR|$  by the number of performed oscillations during the passage of this distance). A similar situation would be for a source resting at some other point  $i$ . Now let the source move in a straight line with a constant speed  $\mathbf{v}$ . Let us conditionally choose a section with a length equal to the wavelength as the signal under study and agree that we will follow the point corresponding to the beginning of this signal (for uniform movement, it would be completely equivalent to follow the movement of the middle or end of this conditionally selected segment). At the moment the signal was sent, the source was at point  $O$ , and at the moment the receiver started receiving the same signal, the source was at point  $j$ . The angle  $\theta$  as usual in the theory of the Doppler effect is “the angle between the velocity and the line of sight measured in the receiver system”. From the relationship of the sides of the triangle (distances, or, wavelengths – if the length of each side is divided by the number  $N$  of oscillations completed during this time), it is easy to determine the change in the period of perceived oscillations  $T'$  compared to the period  $T$  of oscillations of the source at rest at a point  $O$  (where  $T = t/N$ ,  $T' = t'/N$ ). To do this, we use the cosine theorem:

$$(ct)^2 = (vt)^2 + (ct')^2 - 2(ct')(vt) \cos(\pi - \theta).$$

Solving this quadratic equation with respect to  $t'$ , we get

$$t' = t(\sqrt{1 - \beta^2 \sin^2 \theta} - \beta \cos \theta),$$

where, as usual,  $\beta = v/c$ . As a result, we obtain the following

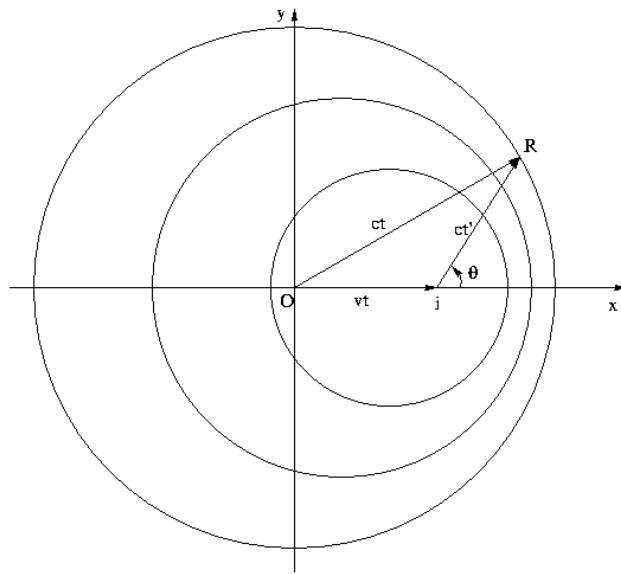

Figure 3.5: Doppler effect when the source moves.

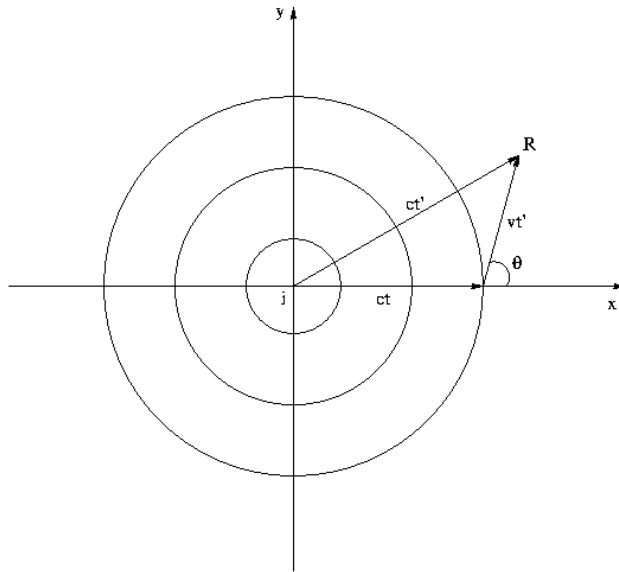

Figure 3.6: Doppler effect when moving the receiver.

expression for a change of the frequency:

$$\nu' = \frac{\nu}{\sqrt{1 - \beta^2 \sin^2 \theta - \beta \cos \theta}}.$$

Let now spherical waves are excited in the medium by a source  $j$  at rest, and the receiver moves rectilinearly with a constant speed  $\mathbf{v}$  and at the moment of the beginning of signal reception is at the point  $R$  (Fig. 3.6). Similarly, using the cosine theorem for a given triangle  $(ct')^2 = (vt')^2 + (ct)^2 - 2(ct)(vt') \cos(\pi - \theta)$  and resolving the quadratic equation with respect to  $t'$ , we find:

$$t' = t \frac{\sqrt{1 - \beta^2 \sin^2 \theta} + \beta \cos \theta}{1 - \beta^2}.$$

As a result, the formula for the Doppler effect for spherical waves

will look like:

$$\nu' = \nu(\sqrt{1 - \beta^2 \sin^2 \theta} - \beta \cos \theta).$$

From the very procedure for obtaining the formula follows its correctness at any distance. In fact, the angle  $\theta$  automatically tracks the distance between the source and the receiver, since, unlike in the case of plane-parallel waves, this angle changes during the motion. In the formula obtained, we are primarily interested in the fact that for spherical waves there exists a transverse Doppler effect (if we substitute  $\theta = \pi/2$  into the formulas), which completely coincides with the relativistic expression. With simultaneous motion of the source and receiver, the Doppler effect for spherical waves has the form:

$$\nu' = \frac{\nu(\sqrt{1 - \beta_1^2 \sin^2 \theta_1} - \beta_1 \cos \theta_1)}{\sqrt{1 - \beta_2^2 \sin^2 \theta_2} - \beta_2 \cos \theta_2}.$$

Now back to “our relativists”. The last of the relativists, who was writing down one relativistic formula simultaneously including both the movement of the source and the movement of the receiver, was Max Laue. Then, apparently, the relativists understood the contradiction of simultaneously taking into account both movements of the very ideology of relativism, but did not agree which of the two formulas to leave (after all, A. Einstein has two of them!). As a result, different formulas are found in the literature of different authors. In addition, it is not clear how one relativistic formula of the Doppler effect could simultaneously give **two** classical formulas of the Doppler effect when passing to the limit (after all, for example, for sound, both of them have been experimentally verified and give different observable results)?

In reality, we obtain the transversal Doppler effect for spherical waves which also exists both for light ( $V_{sig} \equiv c$ ) and in acoustics ( $V_{sig} \equiv V_{sound}$ ) as well! As a result, for the real source, the displacement into the red area will be observed (a greater time of action of such a displaced line), and the effect should depend on the distance to the observation point.

And who could prove that the classical Doppler effect for plane-parallel waves must be applicable for light? This effect possesses the classical form in the case of pure wave motion only, you know. But if light is not entirely a wave, other expressions could be obtained, including the relativistic ones [60]. Thus, the given experiment can not be unconditionally attributed to the experiments confirming the relativistic time slowdown in SRT.

Some relativists [38,107] distinguish three key experiments (by Michelson, Kennedy-Thorndike and Ives-Stilwell) which should unambiguously result in the Lorentz transformations (a basis for SRT). We see, however, that all these three experiments are not evidential. SRT “hangs in the emptiness” even from the experimental point of view.

### **Additional remarks**

We shall begin with some general remarks. For the sake of justice it is necessary to note, that the principle of relativity has never been verified to a maximum experimental accuracy even for the mechanical phenomena. If we believe in the absence of all-penetrating ether, then similar properties can be attributed to the gravitational field. How the observer on the Earth wouldn't be moving (in the rectilinear uniform motion or in circular motion over the Earth surface), the gravity force will change in magnitude or in direction, which can be detected from the comparison of quantitative regularities in the experiments. Therefore, the declared hypothetical experiments could be performed only in the absence of gravitation or in the case of strictly symmetrical distribution of the whole Universe relative to the observation point. But in the presence of moving bodies such a strict “compensation” of gravitation could take place at a single point only. In all real cases one can observe the absolute changes of the state (velocity, acceleration, etc.) relative to the point of space the investigated object passes through at the given instant. Besides, it can be admitted that the rigorous notion of inertial systems must be broadened in an experimental sight and extended to “almost iner-

tial systems”, i.e. to the systems which cannot be distinguished from rigorously inertial systems within the existing accuracy throughout the experiment. Otherwise this notion would be lost for practical applications and would be found useless for physics. For example, it is clear that all “relativistic” experiments without exception were carried out on the non-inertial Earth (the non-inertial nature of the Earth is elementarily proved by Foucault’s pendulum); and if we should approach it absolutely strictly, then it is impossible to involve the principle of relativity of SRT to explain them (infinite rigor “puts an end to it” in any branch of physics).

We make some more general comment. The erroneousness of the relativity theory is in no way related with the presence or absence of all effects the SRT tries to describe and speculate on this (as well as the refusal of crystal spheres does not abolish the really observed planet motion). Two questions must clearly be separated: 1) whether there exists some phenomenon as such or not? and 2) whether some theory, which ascribes an explanation of this phenomenon to “own” achievements, is valid or not? By the “reasons”, which are claimed in SRT, no extraordinary effects can simply exist (the combination of statements and conclusions of the SRT is mutually exclusive, that is logically contradictory). If, nevertheless, some effect is still observed, then it is necessary to search for another real reason (explanation, interpretation) for it. Each theory contains a series of “if”’s, which should be verified experimentally. For example, whether the running of some processes in the object can change, when its velocity really (!) changes? It can, in principle. For example, the first “if” is as follows: the ether exists; the second “if” is as follows: some process depends on the velocity relative to this ether. But in this case the relative velocity of two observation systems will be completely at anything. So, if the first and second system are moving to opposite sides at the same velocity  $v$  relative to the ether, then similar processes in these systems will proceed similarly. If, however, the third system moves to the same side as the first one, but at velocity  $3v$  relative to the ether, then, in spite of the same relative velocity  $2v$ , the processes in the third and first



systems will differ. In the given case the principle of relativity itself (and, the more so as, SRT) is violated. Such a situation is also possible, in principle, but should be verified in the course of experiments only (it is yet to be made by nobody with a required accuracy).

One more remark concerning the experimental results. The scattering of data in each of experiments on measuring the speed of light is high, as a rule. And the small tolerances declared in SRT are obtained only after some certain statistical processing (that is, after fitting under desirable results). This has already resulted in discomfiture: the most probable value of the speed of light, declared by relativists, had been twice changed with obvious escaping the limits of declared tolerances (see [25]).

Note that the light dispersion in the open space was discovered long ago [5]. The delay of waves of different frequencies in space was discovered by Tikhov and Nordman [170]. The dispersion of  $c(\omega)$  in vacuum was suggested in paper [49] (this hypothesis will be considered in Appendixes B and C). The example can be mentioned, where the radiation lines have appeared in 2 months after detecting the X-ray flash [13], which can also have relation to the light dispersion in vacuum.

The classical law of addition of velocities has relation to the translational motion of bodies only. If, however, there exists also the oscillational motion, then, generally, no definite words can be said about the total velocity (even for non-relativistic velocities). For example, the velocity of hammer impact against a tuning fork has no relation to the velocity of propagating waves. No matter how fast the unfortunate bird and the airplane are flying (even with supersonic) and no matter what path they have traveled, after the collision, the speed of sound in the salon of the aircraft will be equal to the same 330 meters per second – it is the speed of sound in the air (obviously, the speed of sound inside the aircraft cabin, defined as  $v_s = \lambda\nu$ , will be constant, regardless of the aircraft's flight speed; similarly, the speed of light, defined inside the instrument as  $c = \lambda\nu = \text{constant}$ , does not depend on any movements outside the instrument, but it does not negate the fact that if the receiver

moves towards the ray, then their meeting will occur earlier, i.e. the final speed, defined as the total path divided by time, will be  $(S_1 + S_2)/t = c + v_r > c$ ). Consider one more example. Let a long rod be moving over the surface of water perpendicular to its length at velocity  $v_1$ , and the point-like source excites the waves in front of a rod. Then these waves will pass some part of the path in water, which rests relative to the rod, at a velocity  $v_2$ , and another part of a path – in water, which rests relative to the shore. As a result, the wave velocity will lie between  $v_2 + v_1$  and  $v_2$  (and will be, generally speaking, a function of the distance to a source). The next example. The local speed of sound relative to the airplane in airplane's saloon with holes will depend on the velocity of a steady airflow inside airplane's saloon (some analog of Fresnel's entrainment coefficient).

Rather strange is a typical “increase of accuracy” at statistical data processing in SRT. This means that the data are artificially selected and those dependencies are analyzed, which certainly meet the given theory. First, the most probable values of various physical quantities can be completely unbound causally with each other even in separate acts of interaction (recall the distinction between the true value and the mean, between most probable and effective value in a particular process of measurement). Second, for essentially nonlinear expressions from the equality of mean (or effective) values it is rather difficult to extract the declared relations for true (instantaneous, or causally bound) quantities. Such an analysis of the data (allegedly confirming SRT) is met nowhere (in this case the theory of fluctuations must be used). Third, the attention should be paid to the following mathematical facts:

- 1) the statistical averaging of a periodic function with unknown period over the other (untrue; for example, if the atom re-emission does not taken into account) period can give a zero result or a quantity lower than true one;
- 2) the attempt to determine a periodic dependence by selecting an incorrectly guessed or shifted harmonics gives zero ( $\int \cos(\omega t) \cos(\omega_1 t + \alpha) dt = 0$ ) or an underestimated quantity. Possibly, the incorrect statistical data processing is just the reason, by

which, in spite of considerable deviations of each of separate measurements from a zero level, rather small oscillations of quantities are obtained in some experiments (of Michelson type) after statistical processing (recall Miller's analysis in his experiments [95]).

It is very "fashionable" to investigate any phenomenon by means of the fine Mossbauer effect. It is rather strange, however, to attribute the temperature effect on the resonance frequency shift in the Pound-Rebka experiments to SRT's time slowdown effect – this is a pure speculation. Though temperature variations influence, to a higher or lower extent, all physical phenomena, but the SRT time bears no relation to an obviously classical field of investigation. Otherwise, if we extrapolate the global claim of relativists quite slightly into a close field – up to melting of a specimen (where the effect itself vanishes), then – what should be declared in this case: the time has stopped its running, the time became singular, or some other delirium? Statistical analysis for the temperature Pound-Rebka experiments is also rather doubtful. It is investigated the influence of temperature and its variations on the frequency shift (but what relation has this influence to some aging?). Recall that temperature characterizes the velocity dispersion inside a sample. But how this effect could be attributed to this sample as a whole? Generally speaking, it is rather strange to associate the Doppler effect with time course or to choose some concrete frequency of a specific process as an indicator of time course. Really, let be a system consisting of a great number of atoms which are excited by help of light with a frequency  $\omega_1$ . Let us choose the frequency  $\omega_1$  as an indicator of time course in this sample. In returning to the basic state, atoms will radiate. But some part of atoms will absorb this radiation; and multiple absorption can also take place. As a result, other frequencies will additionally appear in the system. But, on these grounds, it is inept to believe that time is changed even for such a given atom; to say nothing of the fact, that it is absurd to ascribe a "change in time course" to the sample as a whole and all the more to attribute a something to all reference systems, to which can be mentally associated this sample (exactly similar globalizations are used by SRT

and GRT).

The following methodological remark concerns the terminological forgery, frequently committing by relativists (one of “methods” of the self-affirmation by deception). So, terms with a value of  $c$  in the denominator (for example,  $v/c$ , etc.) came to be called “relativistic” ones, though such the terms frequently appear in the classical case as well, and, at the least, it is necessary to compare analytical expressions for the analogical terms in the classical and relativistic cases. Such the situation of deception takes place in the case of radar observations of the Venus: the rumour was set about an alleged new (!) confirmation of the SRT, though the pure classical formulae were used (see [118]).

### Basic GRT experiments

Though this Chapter 3 is not devoted to the general relativity theory (GRT), nevertheless (because of the relativity theory unity declared by relativists), for completeness of the picture we shall present some additional critical comments to the experiments. It is rather strange, that in some cases the relativists declare the equivalence of description (of Sagnac’s experiment, for example) both within the SRT framework, and with using the non-inertial system within the GRT framework. In the other cases, however, contrary to the declared equivalence of the gravitational field and the non-inertial nature of a system, the SRT gives an inadequately low result (for example, for the Mercury perihelion displacement).

The Hafele-Keating experiment was declared as confirming the GRT. However, this conclusion was made with use of a little sampling (again reduced). Other investigators, which had a free access to the primary data, made quite the opposite conclusion. Besides, the Hafele-Keating experiment was interpreted as the dependence of time on gravitation (actually, the interpretation means change of the carrier frequency itself for a generator in the gravitational field). In such the case, however, it contradicts the interpretation of the Pound-Rebka experiment, where the generator was considered

to provide one and the same frequency at any altitude (and some kind of these two experiments must be eliminated from the “GRT moneybox”).

Some relativists argue with foam at the mouth that GPS fully confirms the conclusions of GRT (and SRT, for a heap). What the relation does this “theory” have to a triangulation, which is familiar to everyone (determining the sides of two triangles by the similarity of these triangles: this was studied in the 7th grade of an ordinary school)? And these pseudo-theories also have no relation to the stability of the frequency and orbit of satellites. It would be not bad for theorists to stop for a while repeating “what should be”, “pull the cotton wool out of their ears” and listen to those whom they themselves called the modest and inconspicuous word “observer” [144], in order to find out, and “what is really there”. After all, it was just these “observers” who participated in the creation of the “preferential frame of reference” (WGS-84, PZ-90, GLONASS, NAVSTAR GPS), contrary to the postulates of SRT, they introduced corrections for the movement of the Earth’s surface relative to navigation satellites, etc. Practical workers (surveyors, engineers, inventors, experimenters) have no time to listen “backdated explanations after the event from theorists”, and they have to act like in the proverb “about a barking dog and a steam locomotive passing by”. Thus, the generators of the NAVSTAR GPS satellite systems are tuned on the Earth to a frequency of 10.22999999545 MHz, so that in orbit the frequency of the generator increases to 10.23 MHz in strict accordance with the Eötvös effect known even before SRT, i.e. long-term navigational experiments refute a single experiment with “flying aircrafts”. You can also read, for example, in [205] what Ron Hatch, the author of over 30 GPS patents, writes, who explicitly states that GPS is contradictory to the theory of relativity.

The gravitational displacement is treated in [33] from the energy point of view, but where the time slowdown in the gravity field has vanished in this case? The attempt to get rid of the relativistic “discordance” was undertaken in [21]. However, the “explanation” with the help of an elevator model (the lift possesses zero initial velocity),

given in that paper, is completely groundless; therefore, the comparison of the Pound-Rebka experiment with the Hafele-Keating experiment can not be considered in favor of the gravitational change in the operation of the watch (remember, in accordance with the GRT, the gravitational field is locally “excluded” inside a freely falling lift). The fact is that all formulas in SRT and GRT are local. Actually, in the aforementioned paper the relativists try “to create” mentally a unified object by means of infinitely rapid signals. Whether the fact, that I set moving the receiver inside a laboratory now, can influence the photon that will be received from the Alpha-Centaur 4 years later? Certainly, it can not! In fact, SRT also considers the signal (a photon and its influence) to propagate at the speed of light (the prehistory of processes is included in none formula). Therefore, we should not consider the elevator velocity at the initial instant to be zero at “explaining” the Pound-Rebka experiment. On the contrary, we should impart to a freely falling elevator such a velocity (it does not influence a remote photon), that at the photon reception instant the “instrument” (perceiving an atom) would be at the same place, as a real resting atom, and would have a zero velocity too. It is clear that the Doppler effect will have no matter at anything in this case, since it depends only on velocity, rather than on acceleration. Both atoms will be at the completely equal position, and the only distinction will lie in the fact that one of the atoms has a support from below, whereas the second one – does not. But, in fact, if the support is removed instantaneously, nothing can change (according to the Doppler effect). However, for obtaining this final state the photons could be sent from different “depths”, i.e. the effect would be different for the same state (place). Therefore, the observed effect represents the influence of exactly changed properties of a photon itself, rather than of the receiving atom position (place). It is just the photon, which becomes more red (but not “the place of reception becomes blue”), which can completely be described in classical terms of the energy loss and changing a real frequency of a photon (rather than changing of observed frequency). The GRT’s “explanation” of this displacement in terms of “bluing the energy

levels of an absorbing atom”, given in [21], is rather doubtful by the other reasons as well. Since the question is here about an individual atom, the given effect can not be a “characteristic of the place” (GRT’s watch). For example, the atoms of gas are always (except the collision instant) in the free falling state, and no displacement at the given place would be observed. In liquids and solid bodies the atoms are moving too (even for  $T \rightarrow 0$ ). Therefore, instead of distinct displacement of a line (this effect is highly sensitive even to velocities of some cm/s), the complete spreading of a line would be observed. But in any case not a “universal gravitational GRT effect” is obtained [21], but the effect, which depends on particular non-relativistic mechanisms participating in the given process. It is easy to take refuge (hide) in resonance effects (the presence of radiation lines), but if do we consider transitions to the continuous spectrum? Where does the continuous spectrum know the path passed by the photon from? And we must take into account that not each photon “falling” on an atom will be absorbed, but some photons always fly past just the same place “become blue” which waited for them. And if is any medium absent at all? Let a photon leave the “black hole”, for example. It fly itself with one and the same energy, and places, which it flies by on the way, “become more and more blue” all the time. A fine poetry! The manipulation with mathematical symbols can not be considered as the “explanation” in physics (for example, the masslessness condition in the third “explanation” of [21] is nothing else, but a hypothesis). The fact, that the Pound-Rebka experiment’s explanation is correct in the terms of energy exactly (the change of energy signifies the change of a photon frequency), is clear from following mental experiment (see Fig. 3.5). Let an electron and positron be annihilated in the gravitational field  $\mathbf{g}$  underneath. Let the two obtained photons be reflected upwards. Let now the birth of a pair of particles to take place again from these photons overhead. If the energy of photons did not change at their rising in the field of gravity (recall a customary air on the Earth), then how could we without energy consumption lift the particles in the field of gravity to a high altitude (i.e. we have imparted them

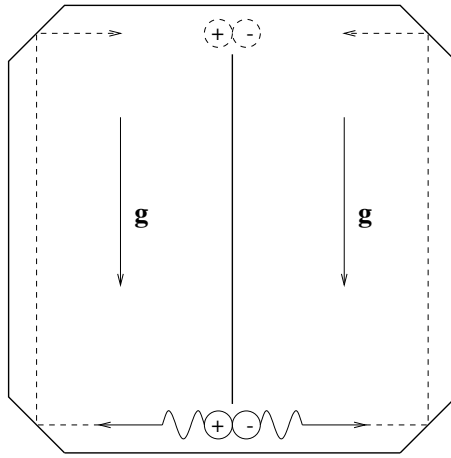

Figure 3.7: Perpetuum mobile of GRT.

some additional potential energy)? Is it a perpetuum mobile, really? The similar contradiction will be more pronounced (and without using auxiliary reflections), if we use reaction of the other type, with radiation of one gamma-quantum, below and the appropriate reverse reaction above.

It seems rather strange that some relativists declare a possibility and necessity of the experimental verification of an “allegedly existing” space curvature (for our sole Universe!): but relative what could this curvature be measured? In fact, experiments can register only occurring variations with physical values (the method of comparison with the standards).

### Modern “confirmations” of GRT

In the review [198], some new “successes” in the verification of general relativity are pathetically promoted. Thus, in [194], the principle of mass equivalence is discussed, ostensibly taking into account the gravitational coupling energy (by delaying the laser signal sent from the Earth and reflected from the Moon). This problem is com-



pletely contrived and does not depend on the “immense size”, since the equality of the masses is already incorporated in the quantitative determination of the magnitude of the gravitational constant (and the energy of the gravitational coupling is local, since the principle of close interaction is proclaimed). Attracting cosmic scales rather worsens the situation, due to the uncontrollability of many parameters. So, in space there exist a medium and fields that affect the propagation of a signal; even the problem of three material points is not solved exactly, and the number of objects in the Solar System is even greater; the exact mass values of astronomical objects are unknown; all objects are in motion (not inertial) and have complex (non-point) forms; geophysical processes are not taken into account (for example, there is no exact theory of tides, and they manifest themselves not only on water, but also on land surface).

Further, there are a number of doubts on the results of [186,187], using radio interferometers with a super-long base. None of the experiments is direct (but only interpretations). The exact mass of the Sun is unknown. And who can determine the exact distances to the Sun or to the vehicles, if the exact path is unknown (it will not be rectilinear, since it depends on the presence of the solar corona, characteristics of the plasma propagation medium)? How can you determine the accuracy of the path difference for a long base taking into account the uncertainty of all angles, the presence of density and plasma temperature gradients? None of the delay times  $\tau$  can be controlled (i.e., everything is tied up with faith!). Since the phase delay was not subordinate to GTR, a “group delay” was invented to fit under the results (the statistical analysis followed the same purpose). Many ideas about the processes were of a model nature, but since so many models are introduced, then what is being verified? Similarly, whether not too many parameters “were tested” by **only one** experiment [199] with the lunar laser ranging? The value to be checked must also be **only one** (under the condition of all other known parameters). Regarding declarations [200], where primary data are not provided, a number of observations can also be made. The Earth and the Moon are not inertial systems (move

in space with acceleration); there is no way to control the distance to the reflectors and the constancy of the speed of light (the properties of the propagation medium change); neither the mass shape of the participating objects, nor geophysical processes are taken into account. By the way, information about the radar observations of Venus, which confirm classical physics (the classical law of velocity addition), can be found in [196,197].

In [178, 182], a microwave communication system aboard the Cassini spacecraft is used for “evidence”. Despite such a variety of methods, the disadvantages are the same: the exact distributions of density, temperature, fields in the plasma are unknown; therefore, the exact  $\varepsilon_{\alpha\beta}(\omega)$  is unknown, etc.

Now we mention about the “evidence” with the help of pulsars [181,185,195]. Here it is not clear which of the hypotheses is tested by which of hypothesis: after all, the device of pulsars, their modes and mechanisms, their orbits and the distances to them are just assumptions; the path to them and the properties of the propagation medium are also unknown. There is no exact solution to the N-body problem in any theory, even for 3 material points. In [181], some combinations of parameters (some letters) are used, none of which can be precisely controlled. What is this test (and even more – “proof”)?

Numerous claimed “experimental verifications” of GRT all require “different metrics”, thus implying the “experimental verification” in each real case: a mathematical scheme consisting in selecting the metric that achieves a desired result (artificial fitting).

Summarizing the criticism of the basis of the relativity theory, the conclusion follows that we must return to the classical Newtonian concepts of space and time. We must also return to the classical additive vector law of velocity addition for particles.

### **Once again about the speed of light**

To begin with, it is necessary to methodically determine what is meant by the speed of such an “object” as light. Of course, the

classical definition of speed is methodically preferable, as the ratio of the distance traveled to the elapsed time  $\mathbf{V} = \Delta\mathbf{R}/\Delta t$ , since this definition does not at all distort the “object” in the process of its movement. But the definition of the speed of light in terms of the product of the wavelength and the frequency  $V = \lambda\nu$  immediately raises several questions. First, we do not directly see the process of electromagnetic oscillations itself (unlike mechanical oscillations). Therefore, we cannot be absolutely sure in advance whether the “object” itself possesses wave properties, or whether wave properties are only manifested (generated) in the process of its interaction with the measuring device. Secondly, the speed calculated by the second method is the speed of some wave process **inside our measuring device**. Therefore, we still need to prove that the speed of our “object” (light) outside the device coincides with this speed inside the device (in a different environment!). There is no definitive evidence, as far as we can see.

The notion of “velocity” is clearly determined (remember the road police), and only for “the secret agent 007 - light” there exist many “passports” (according to relativists): some “Great” constant (for “a relativistic oath”); coordinate velocity (in this case relativists cannot to hide the necessity of “blasphemous” term  $c \pm v$  in any way) – but what can be “taken” from it; phase velocity (with it land-surveyors work [144], opticians calculate microscopes and telescopes with it, astronomers calculate refraction with it etc.); group velocity (which was “with regret” introduced by Rayleigh and which is almost not used by practical workers, but which is often declared as “true” by relativists, if it does “accidentally” not turn out negative, or more than the constant nominated by them themselves). Sheer “a card-sharping with three glasses at a railway station building”: have guessed right or not?

Though the problem of light speed has been considered above, we shall here formulate more clearly the law of velocity addition for a light signal (for the corpuscular and wave models of light) in the example of one-dimensional motion. Let the axis be directed from the source to the receiver. Let the source at distance  $L$  from the

receiver to emit a light beam having some frequency characteristic  $\omega_0$ . Then two situations are possible:

1) Irrespective of the nature of light, when the receiver moves at speed  $v$  relative to the source, the signal reception rate ( $L/t$ ) will be determined by the geometrical sum  $c(\omega_0) - v$ , and the frequency of received light will be determined by the simplest classical Doppler law:  $\omega = \omega_0(1 - v/c)$ . The question – what local velocity (all measurements are made inside the receiver of the fixed configuration) will be recorded by the receiver – is completely different: this quantity can depend on the nature of light (a wave, or a point particle, or a particle with inner degrees of freedom), on the receiver design, on frequency  $\omega$ , etc.

2) When the signal source moves at speed  $v$ , the result necessarily depends on the nature of light. If light represents a flux of particles, then we obtain again the classical linear law of velocity addition:  $c(\omega_0) + v$ . If light represents a wave, we actually deal with the addition of translational and oscillatory motions, and the theorist cannot write down the  $c[\omega(v)]$  dependence and the Doppler law in the explicit form (the general exact form). For the value of velocity, we can find, in principle, the linkage with characteristics of the “medium of propagation”. Recall, for example, that the speed of sound in gases can be expressed in terms of the following quantities: the molecular weight of the gas, temperature, adiabatic index. For rigid bodies, the longitudinal and transverse speeds of sound are expressed in terms of density, Young’s modulus and Poisson’s coefficient; for liquids it is necessary to know some empirical coefficients. One of the possible hypotheses on the propagation rate for light in vacuum will be presented in Appendixes B and C, where the light propagation process will be supposed to be mainly influenced by virtual electron-positron pairs. As far as the frequency is concerned, we find that it will be determined by the simple Doppler law  $\omega = \omega_0/(1 - v/c)$  within the limit of small oscillations only. In the case of arbitrary distances, directions of motion, arbitrary fields, possible presence of ether or of an inner structure of light (with additional degrees of freedom) for different models of light,

all dependencies can become much more complicated. Thus, in the general case, the determination of the law of velocity addition, the determination of the light speed itself (again – not local, inside the receiver, but in vacuum between the source and receiver!) and the Doppler law – are the prerogative of experiment.

Generally speaking, the speed of light cannot be constant, if only because the velocity is a vector quantity (it has a direction). So, with reflections from mirrors, the velocity changes. If relativists try to postulate the conservation of the modulus of the velocity of light, then reflections result in infinite accelerations. Why is such the result with a singularity better?

We note some interesting facts. The speed of light is deliberately chosen in SRT as the maximum speed (an insurmountable boundary). The relativistic law of speed addition is designed so that the total speed is always no more than the speed of light, i.e. it would be impossible to board the “photic” train. Moreover, if we choose one of the speeds equal to  $c$ , then the final speed will also be equal to  $c$ , regardless of the direction of the second speed. That is, it would also be impossible to get off the “photic” train. However, if for the mythical world of tachyons, we immediately choose speeds greater than the speed of light, then we will still get a value less than the speed of light. At the same time, exactly the same final speed can also be obtained by adding two speeds, each of which is less than the speed of light [155]:

$$\frac{nc + nc}{1 + \frac{nc \cdot nc}{c^2}} = \frac{\frac{c}{n} + \frac{c}{n}}{1 + \left(\frac{c}{n}\right) \cdot \left(\frac{c}{n}\right) / c^2} = \frac{2nc}{1 + n^2} < c.$$

For example, the relativistic addition of two motions with velocities of  $2c$  gives a final velocity of  $4c/5$ , as well as the addition of two velocities of  $c/2$ . Thus, an ambiguity arises: do we observe a certain particle formed during the subluminal decay of a real particle from our world, or do we see the superluminal decay of mythical tachyons, which allegedly to be impossible to see. It is also very strange that it would be impossible to launch a superluminal probe forward from

a superluminal rocket – it would pierce the rocket body, flying at subluminal speed back relative to the rocket.

### **3.2 Conclusions to Chapter 3**

Since physics primarily represents an experimental science and the majority of textbooks begins precisely from the experimental “substantiation” of the relativity theory, then there was a need (despite the presence of logical flaws in RT) to analyze the relativistic interpretation of a number of experiments and show its fallacy (we do not bear in mind that the experimental data are erroneous: the experimenter is always right!). The given Chapter 3 above analyzed in detail the experiments, which led to the approval of SRT, from the corpuscular and wave viewpoints for the empty space (with using of relativity principle). It was shown that all these experiments could give nothing except a “zero result” since the only possible light-speed dependence  $c(\omega)$  was not studied at all. Further, we analyzed those experiments that allegedly confirm SRT, and presented a series of methodological comments.

The Chapter 3 contains both the general comments on the experimental substantiation of the relativity principle, on the theories of ether, on statistical data processing and others, as well as the specific critical discussion of the aberration phenomenon, the experiments by Michelson-Morley, Kennedy-Thorndike, Ives-Stilwell and others. The complete inadequacy of interpretations of these experiments within the SRT framework was demonstrated here. Such GRT experiments, as the Hafele-Keating and Pound-Rebka experiments, were discussed at the end of the present Chapter 3, and errorness of their interpretation by GRT was shown. The given Chapter 3 demonstrated a full experimental groundlessness of the RT.

## Chapter 4

# Dynamics of the special relativity theory

### 4.1 Introduction

In the previous Chapters we have proved the inconsistency of kinematic concepts of SRT, the groundlessness of GRT, the invalidity of relativistic interpretations for a number of key experiments (even if after that we treat the theory of relativity as a mnemonic rule, then this is too cumbersome and unwise). Although this is quite enough in order to seek interpretations of observed phenomena other than relativistic ones, nevertheless, the present Chapter 4 supplements to the aforementioned systematic criticism of the relativity theory. The fact is that all textbooks (starting with school ones) tune us in to the idea of so-called progress based on the achievements of modern science, one of the bases of which is advertised the theory of relativity (for some reason, the atomic bombs and accelerators are mentioned in this case). However, even here the situation is far from being so rosy (although theorists fanatically believe that only the “hooks” they write are directly related to reality): according to “ideal” theoretical calculations, no accelerator reaches its design power – in practical courses and engineering calculations, in most cases, phenomenological formulas and “fitting” parameters

and factors are used. The main purpose of this Chapter 4 is to demonstrate that even in the only seemingly practical SRT section, namely, in the relativistic dynamics, there exist numerous questions, compelling one to doubt in the validity of relativistic ideas and in interpreting their results.

It is well known a philosophical statement (distinctly applicable to SRT): “we can see that thing in the experiment only we want to see there”. Such an attitude is prepared and the situation is aggravated by the theorists, who are “stewed in their own juice” and ready to see in every experiment only confirmation to their tricks with mathematical symbols (although the author belongs to theorists as well). The existing uncertainties of the theory (carefully masked in SRT) allow the theorists to vary interpretation of experiments within considerable limits. And, afterwards, the incompleteness of experiments is masked “in a proper manner” by statistical “fitting” of the data (data “truncation” under the desirable result).

In deriving the equations of motion of an electric charge and the field equations in theoretical physics’ courses, an attempt is made to cause an illusion of an “unequivocal idyll”. But in such a case the Maxwell equations would be the equations of any fields, and all forces would be of Lorentz type and would have the form of Coulomb’s law in a static case. For the gravitational field, such an alternative to the general relativity theory (GRT) can be discussed (with some supplementation and modifications). However, the situation is different in the general case: for example, the nuclear forces are not proportional to  $R^{-2}$ . There exist many counterexamples of various fields and forces. Therefore, the theoretical physics (including the SRT approach) cannot determine all existing phenomena proceeding from their own principles only. This is an exclusive prerogative of the experiment. (Besides, the experimenter should be principally prepared to the fact that any theory can occur to be inaccurate or even wrong).

Also surprising is the apologetic advertisement of SRT. For example, the pathos’s assertion of [40], that “the relationship between the mass and energy underlies the entire nuclear power engineering”



is groundless both in the historical and in the practical respect. This relationship bears no relation either to discovery of elementary particles and radioactivity, or to studying the spontaneous and forced decaying of uranium nuclei, or to determining the stability of nuclei, or to finding possible channels of nuclear reactions and possibility of practical choice between them, or to the isotope separation technology, or to practical utilization of released energy, etc. Thus, the relationship between mass and energy bears no relation to any key stage in the development of nuclear power engineering. And (as paradoxical it may seem) this relationship bears no relation even to determining the released energy in any particular well-known reaction. Because historically everything happened in a different (reverse) sequence: at first, a certain reaction was detected, which was detected precisely by the release of energy. And after that, you can enter calculational functions (the combinations of mathematical symbols) in various ways. As a rule, it is technically impossible to determine the mass variation in a nuclear reaction directly. Even if one uses doubtful theoretical interpretations, the attempt to determine the mass variation will occur to be a rather rough and costly pleasure. Thus, the relationship between the mass and energy plays, in the practical respect, a role of scholastic mathematical exercises on reverse substitutions, since desirable results can always be “derived” from the calculated data, which were earlier tabulated post factum. In principle, you can learn to navigate the World by looking at its reflection in “Troll’s crooked mirror” (through the prism of relativistic pseudo-theories); but is it worth making life so difficult for Humanity, and at the same time sinning by calling the World crooked?

Let us make a preliminary key remark. From a philosophical point of view, it is obvious that the theory of relativity (with its absolutization of the concept of relativity), even if it were not false, in principle could not be a more general theory than classical mechanics, in which there are clear examples of the insufficiency of some relative quantities. And this is not only an example of closed and open systems (the phenomena in the hold and on the deck of

the ship are different). The presence, in addition to kinematic, of any dynamic characteristics “belonging” to a particular object immediately individualizes the process. Consider an elementary school example. Let the ball inelastically fall to the Earth. The relative velocity is the same for both the ball and the Earth, as it “belongs” to both objects. Let us define the **kinetic energy** converted into heat. Why do we substitute the mass of the ball into the formula, and not the mass of the planet Earth? Just because otherwise it would obviously have turned out to be an inadequately large result? This example shows that only locally absolute velocities play a role (then both answers **strictly give the same** and do not depend on our choice). When using relative velocity, however, you can only get a **approximate** answer, but only with the help of the mass of the ball.

## 4.2 Notions of relativistic dynamics

Now we shall proceed to a more complicated problem of dynamical concepts of SRT. It would seem that only in the relativistic kinematics there are no direct experimental comparisons of values of physical quantities (only doubtful interpretations) for two systems moving relative to each other; but in the relativistic dynamics everything is in order (according to relativists’ logic – the accelerators are operating, in fact!). Let us try to clear up the dynamical concepts, even because the relativistic dynamics, under modern interpretation of SRT apologists, rests upon a completely untrue relativistic kinematics.

We begin with general notes. A boundless spreading of the idea of relativity of all quantities in SRT is completely groundless. Really, let the two bodies be at distance  $\mathbf{r}$  apart of each other while having relative velocity  $\mathbf{v}$ . Then the result of interaction of these bodies at instant  $t + dt$  will not be determined by mentioned characteristics, but will depend on the prehistory of motion. Since the effect spreads at finite velocity, the first body at instant  $t_1$  will be influenced not by the real second body (at instant  $t_1$ ) with its co-

ordinates and velocity, but by some its “image” from a preceding point of the trajectory, from which the effect had time to be received before instant  $t_1$ . Thus, any physical quantity (the force, for instance) can not depend on the relative velocity at the same instant only. The only exception is the frontal collision, at which  $\mathbf{r} = 0$ . Therefore, it is necessary either to apply more complicated equations instead of the local differential equations (i.e. to take into account the prehistory), or to refuse from the idea of relativity of all quantities. Even the notion of the “relative velocity at the given time instant” itself becomes indefinite, because any real effect will be determined by characteristics at preceding instants. And, you see, SRT does not “know” the absolute velocity organically (it “knows” only the relative one). This fact has already resulted in the discomfiture. For example, Einstein has actually believed the stellar aberration to depend on the relative velocity of the Earth and a star (see [41], v.1). However, the experiment shows the stellar aberration to be dependent on the Earth velocity only, but the velocity of a star has no effect at all. In spite of vast scattering of velocities of stars, the aberration on the Earth is found to be the same for all stars. Where has the relative velocity gone in such a case? Actually, even this fact disproves the original concept of SRT. An obvious contradiction with the largest “puncture” is obtained for spectroscopically binary systems. Since the periods of revolution of such binary stars are small, and the velocities are high, then, according to the SRT, for an observer on the Earth, these stars on opposite parts of the orbit should differ by tens of angular seconds from their opposite position (aberration, for example, as with the Earth’s movement along its orbit). However, no one has ever recorded such “jumps”.

A similar disproof of SRT is obtained in the problem on a coil in the magnetic field: the motion of a coil induces the current in it immediately, whereas the motion of a magnet (according to the finiteness of the rate of interactions) – only after some time. There exists no symmetry of the problem, and the dependence on the relative velocity only is obviously insufficient.

### The concept of mass

Now we proceed to more specific dynamical concepts. We begin with the concept of “mass”. In order to introduce correctly the new physical concept of the “mass of a moving body” into SRT, it is necessary, primarily, to determine the procedure of measuring similar moving masses independently of any theory. (A similar procedure in GRT relates to the “mass of a body in the gravitational field”: to determine the distinction of the gravitation mass from inert one, contrary to its own postulate). Moreover, this should be precisely a measurement, rather than a recalculation, for example, via the again postulated formula for energy or momentum. Otherwise the theory is trying to “pull itself up by the hair”. A similar measurement procedure does not exist for SRT.

The physical concept of “mass” has no direct relation to all those formulas (it is mathematics), which can include letter “ $m$ ”. For the basis concept of mass there exists the only clear – the definition with using the standard. It determines the mass just at the state of rest (for example, the conditions also exist for the standard of length – the temperature ones). And there is no need to “invent a bicycle”. In the motion the mass is simply not defined, though letter  $m$  can enter quite diverse formulas containing  $\mathbf{v}$ ,  $\mathbf{a}$ , etc. These are different things! Therefore, the definition of an elementary concept of mass in terms of more complicatedly defined concepts of energy and momentum (which depend on the theory, interpretation, state of a system, etc.) – is a physical nonsense (though, possibly, this could be sometimes mathematically correct). In such a manner one can “reach” an absurd and define a simple notion of velocity as  $\mathbf{v} = \mathbf{p}c^2/E$ . Note that any experiment, including a measurement experiment, should be extremely clear defined with respect to all conditions of its performing. But, generally speaking, the “explanations” and “definitions” of theoretical physics (for example, in SRT) by themselves often represent a drop-out from physical understanding; this is simple a pseudo-science masking of the false essence of new quantities behind mathematical transformations (often correct).

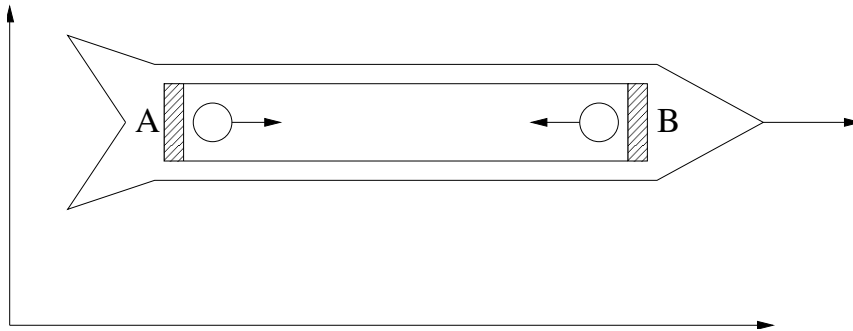

Figure 4.1: The center of mass of a tube with cannonballs.

### The notion of the center of masses

Even such a simple notion as “the center of masses of a system” becomes ambiguous in SRT in taking into account the mutual motion of system’s components. So, for example, the “paradox of the center of mass” is considered in [33]: in the rocket system of reference, two identical cannonballs are fired simultaneously from both ends into the tube, and the ends of the tube are immediately tightly closed with plugs *A* and *B* (Fig. 4.1 ). In the classical physics no contradictions arise in this case: the center of masses in any frame of reference will always coincide with the center of the tube. It can be determined by various methods, namely: by weighing and direct calculation (the mass and distances are invariant in the classics), as a center of zero momentum, as a center of a baryon number (the number of nucleons in nuclei), as a center of gravitational attraction. The notion of the center of baryon number was declared “non-productive” in [33], since the world line of this center occurs to be irrelevant to the SRT laws (that is, it simply contradicts them!). The gravitation is organically not included into SRT, so that one should transfer to GRT, but the book [33] declares the coincidence of the center of gravitational attraction with the middle of a tube in the laboratory coordinate system (but for some reason, “the center

of zero momentum” is studied in this case). However, immediately after the first collision with a plug (non-simultaneous in the laboratory system) it becomes necessary to refuse from the universality of SRT and to recall about a specific compensation mechanism (for “saving” SRT) – about the acoustic waves in the tube and about the energy (mass) transfer by them. These waves, coming from tube’s ends, then suppress each other. But in such a case one should have to postulate various velocities of acoustic waves in various systems for two opposite directions. And if we will change the material of a tube and the geometrical characteristics of the experiment? And if the tube is absent at all and only the plugs of very great mass are present, and the sensitivity of local gravitation measurements will allow for determining the motion of cannon balls? And what should be done with the compensation mechanism in the cases listed above?

If in the given problem we shall determine the mass from the momentum transfer on plugs  $A$  and  $B$  or on barriers parallel to them (the “longitudinal” mass), then we obtain some one world line of the center of masses. If, however, the mass will be determined from the pressure on the tube bottom (due to the gravitation, the electrical force for charged cannon balls or due to the magnetic force for magnetic cannonballs), then the other world lines will exist for this (“transversal”) mass. Generally speaking, in SRT all these world lines will be different. Some of them have to be postulated as senseless (non-productive for SRT), in some cases it would be necessary to pass to particular mechanisms “explaining” the contradiction, and in other cases the change of objective characteristics should be postulated. For example, let the plug hold on to a massive tube with a little more force, than that required in order to the plug could be torn off by a cannonball (with “relativistic” mass) in the rocket’s system of reference. Therefore, in the laboratory frame of reference, one of cannonballs (with a greater “relativistic” mass in this case) will knock out the plug. So, is the observer behind this plug alive or dead? Or, again, for “saving” SRT it is necessary to postulate that the limit of holding a plug in SRT is not an objective

characteristic (but depends on the frame of reference)? And if there will be the “traps” at the bottom at tube’s ends, in order that in the rocket’s system of reference, the “transversal relativistic” mass be slightly insufficient for falling a cannonball down. Then, again, in the laboratory frame of reference one of cannonballs (with a greater “relativistic” mass) will fall down. So, shall we postulate again a change in the strength threshold to “save” SRT? Note that it would be necessary to postulate different threshold characteristics: both the longitudinal and transversal (generally, tensor) ones. Whether the SRT price is not too great – the price of postulating a loss of the majority of objective characteristics? Aren’t there too many problems, questions and contradictions “out of nowhere”, where everything was elementarily simple in the classical physics? But, as you know, SRT can not refuse from the concept of the center of masses, since the Einsteinian derivation of the  $E = m_0c^2$  equivalence for the “rest mass” is based on this particular concept.

### Forces in SRT

SRT gives nothing useful in the kinematics and for dynamical concepts as well. It occurs that all this huge number of additional complications arises only because of the fact, that the electromagnetic Lorentz force too “complicatedly” depends on the velocity (or on acceleration as well, if we will try to reduce its effect to the classical Newton’s second law)?! We will make a light lyrical digression. On what quantities can forces depend (and, from a general point of view, what is the difference between the approaches of Aristotle and Newton)? An interaction of bodies leads to a change of the bodies’ state. It is necessary to choose an “indicator” of this change. Aristotel believed the state of rest as the basis state, and as an indicator he chose to observe the velocity of body’s motion, i.e.  $\mathbf{v} = \mathbf{f}(t, \mathbf{r})$  (Aristotel associated the value of  $\mathbf{f}(t, \mathbf{r})$  with a force that causes movement). The choice  $\mathbf{v} = \mathbf{f}(t, \mathbf{r})$  is quite sufficient, if we will be satisfied with contemplation. However, if you try to construct the dynamics of movement, then after the mental exper-

iments of Galileo, it became clear that the Aristotelian concept of force does not correspond to the reality. Though, strictly speaking, this conclusion is tied to the faith of relativists of “the first wave” – Galilean followers – in existence of empty space (Galileo himself considered only isolated identical systems and, unlike his “pseudo-followers”, did not extend his principle to the mutually penetrating systems of reference). If ether exists, the Aristotelian rest is locally tied to the ether, which as a whole does not have necessity to be “uniformly immovable” at all, but can participate in complex vortical movements. For example, there exists the theory of vortical dynamics of the solar system, and a force is required only to maintain motion, which is differ from the equilibrium motion. However, the analysis of vortical dynamics is not included in the book plan, and so, we will use the statements generally accepted in the present state. The Newtonian choice of the method for the description of bodies’ interaction is different – body’s acceleration is chosen as an “indicator” of change of body’s state. In essence, the Newton’s second law represents a definition of the notion of “a force”, and, from a standpoint of functional dependence, the force coincides with the acceleration up to a dimensional factor (mass). Ideally, this way of a motion description (in the habitual form) must be written as  $m\mathbf{a} = \mathbf{F}(t, \mathbf{r}, \mathbf{v})$ . However, the problem of finding the explicit expression for such the “ideal” forces  $\mathbf{F}(t, \mathbf{r}, \mathbf{v})$  is not yet solved for the case of arbitrary configurations and motions of a body, a force source and a medium, for example, based on expressions for statical forces. Nature does not always easily reveal its secrets to us: instead of an ideal expression of the force, we have to use an expression that we found  $\mathbf{F}(t, \mathbf{r}, \mathbf{v}) = \mathbf{F}_1(t, \mathbf{r}, \mathbf{v}, \dots)$ . Thus, generally speaking, the real forces should be determined from the experiment. The following forces are known:

$$\mathbf{F} = \text{constant}, \quad \mathbf{F} = \mathbf{F}(t), \quad \mathbf{F} = \mathbf{F}(\mathbf{r}), \quad \mathbf{F} = \mathbf{F}(t, \mathbf{r}, \mathbf{v}), \quad \mathbf{F} = \mathbf{F}(d^3\mathbf{r}/dt^3)$$

and so on in quite various combinations. From the generalized expression

$$\mathbf{F} = \mathbf{F}(t, \mathbf{r}, \dot{\mathbf{r}}, \dots, d^3\mathbf{r}/dt^3, \dots)$$



it is seen that any derivative, including the second one, is not singled out by anything, and only the experiment can determine the varieties of forces realized in the nature (for example, recall the formula proposed by Weber long before SRT, where the force also depended on acceleration). Here we are interested in the fact that the relativistic equation of motion with the Lorentz force  $\mathbf{F}(t, \mathbf{r}, \dot{\mathbf{r}})$  can be written as the classical Newton's second law with the force  $\mathbf{F}(t, \mathbf{r}, \dot{\mathbf{r}}, \ddot{\mathbf{r}})$ . Though, if one believes in the relativistic expression for forces, then, as an alternative, transformations can be introduced for components of the force, longitudinal and perpendicular to body's velocity (but it does not worth to introduce mythical longitudinal and transverse masses). Or we can just write the classical Newton's second law  $\mathbf{F} = m\mathbf{a}$  and the relationship of new force  $\mathbf{F}$  and the static force  $\mathbf{F}_0$ :

$$\mathbf{F} = \sqrt{1 - v^2/c^2}[\mathbf{F}_0 - \mathbf{v}(\mathbf{v}\mathbf{F}_0)/c^2].$$

One should not also exaggerate the possibilities of the methods for obtaining expressions from the Lagrangian, since this function itself is determined to an accuracy of some expansion terms and can not determinate the principles.

Methodically, the transformation of forces in SRT looks completely incomprehensible in the transition from one frame of reference to another. Let us consider, for example, two identical in absolute value charges  $+e$  and  $-e$  being at distance  $\mathbf{r}$  apart of each other (Fig. 4.2). In the system of reference associated with resting charges, the electric force  $F = e^2/r^2$  acts between these charges. Now let's look at the same charges from the system moving at a velocity  $\mathbf{v}'$  perpendicular to the line connecting the charges. In this system, the charges fly parallel to each other. According to SRT [17,32], now the force acts between the charges:

$$F' = Ge^2/r^2, \quad \text{where} \quad G = \sqrt{1 - v'^2/c^2}.$$

With what physical quantity should the transformation factor  $G$  be associated? The charge is invariant in SRT. Distance  $r$ , which

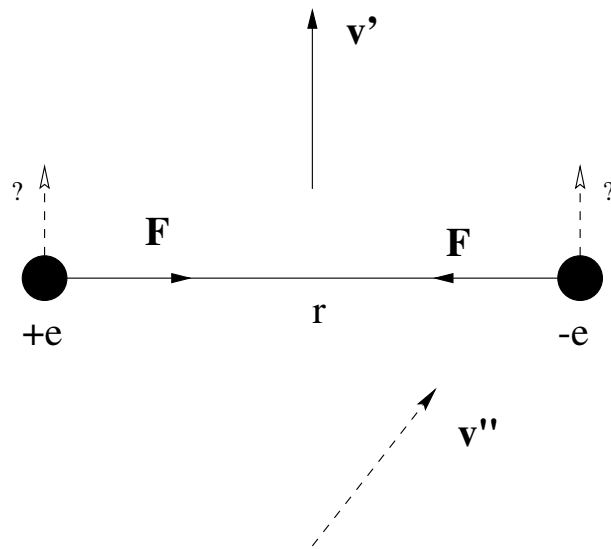

Figure 4.2: Parallel flying charges.

is perpendicular to the motion, does not change as well. So, do the forces really lose their physical causes in SRT? Note one more strange thing: if the velocity of an observer  $\mathbf{v}$  has a component along the line which connects the charges, then the force acting on the charges has a component which is perpendicular to this line (i.e. the picture of motion will be essentially changed).

Einstein's statement is completely groundless, that uncharged bodies must behave under an effect of forces in exactly the same manner as charged ones: all forces must allegedly be transformed identically. Still Poincare wrote that we can not arbitrarily "disconnect" some force from one body and arbitrarily "connect" it to the other body. If some force (for example, electrical) acts on some (charged) bodies and does not act at all on the other (uncharged) bodies, then, all the more, is not obvious that velocity dependencies should be identical in transformations of all forces. This is one more hypothesis not confirmed by anything even within the SRT framework. Probably, the transformation of forces has relation to only one particular case – the Lorentz force. And even in this case there are some nuances here. For example, at transition to a moving system the magnetic force magnitude can become zero. These facts represent the manifestations of conventional character of separating a single force into electrical and magnetic forces, don't they? In such a case, why should the large attention be concentrated on the transformation of conventionally separated electrical and magnetic fields (and forces)?

Generally speaking, the idea that one and the same force can be different for different systems of observation is the flat nonsense for all experimental physics. Really, the way of writing arabic cipher on a dynamometer is independent on observer's motion, i.e. readings of the dynamometer (fixing the force) will not be changed with observer motions. Any force acts between the "source" of this force and the concrete "object" of the applied force, but motion of some "strange eyes" has no relation at all (i.e. force can depend on the source properties, on object properties, and on their mutual motion).

### Energy and momentum in SRT

We begin with a comment concerning the units of measurement. The expression for the momentum and energy in terms of a mass can not give anything useful, since these quantities are not interchangeable, the number of joint operations with them (as well as combinations) is limited and, all the same, it is necessary to monitor them as various physical quantities. Whether is it worth to introduce confusion into well-agreed units of dimensions?

Whether the SRT approach to the relativistic dynamics is the only one? Not at all! In the classical physics, the separation of energy into kinetic and potential ones can be rather conventional. For example, in the statistical physics at description of motion in non-inertial rotating systems, the potential energy includes, in fact, the mean kinetic (!) energy of motion of the system: from  $v_\varphi = \Omega\rho$  is generated  $E_{pot} = m\Omega^2\rho^2/2$ . There exists another educative example from the hydrodynamics, where the appended (“effective”) mass concept is introduced for describing the motion of a body through a medium. The true mass did not obviously change in this case. In exactly the same manner, in the relativistic mechanics, a new “velocity” addition to the acceleration can be associated with the potential energy of a body. In this case the kinetic energy of a body can be retained invariable, and the classical Newtonian equations can be considered, but with other, “effective” force and constant mass  $m_0$ .

Contrary to the SRT assertions on the importance and necessity of introducing the 4-dimensional vectors, even for three interacting particles, the expression

$$E = \sum_i m^{(i)} c^2 \gamma^{(i)}, \quad \mathbf{P} = \sum_i m^{(i)} \mathbf{v}^{(i)} \gamma^{(i)}, \quad \text{where } \gamma^{(i)} = \frac{1}{\sqrt{1 - v_i^2/c^2}}$$

does not constitute the 4-dimensional vector and is not conserved. The introduction of the potential energy of particle interaction also causes some difficulties. Is SRT a theory of two bodies, really? Where is the declared generality (universality) of the theory? Simi-

lar difficulties arise in constructing the Lagrangian and Hamiltonian functions for systems of interacting particles.

A limiting transition to the classical energy is contradictory too. Above we have considered the condition of such a transition:  $c \rightarrow \infty$ . But in such a case, not only the energy of rest, but any other energy will be  $E = \infty$  in SRT. The expression for the relativistic momentum in the form of [26] is also not consistent:  $\mathbf{P} = m d\mathbf{r}/d\tau$ , since  $d\mathbf{r}$  relates to the motionless frame of reference, but the intrinsic (proper) time  $d\tau$  relates to the moving system (i.e. to a body).

The transition to the limit of low velocities also raises a series of questions. According to the correspondence principle, all formulas should proceed to the Newtonian form when the transmission rate of interactions is assumed to be infinite (for example, the Lagrangian function, action, energy, Hamiltonian function, etc.). However, we see [17] that this is not so: the four-velocity goes into a set of four numbers (1,0,0,0) and does not mean anything, the four-acceleration does the same; the interval  $S \rightarrow \infty$  and the value of  $dS$  depends on the order of passage to the limit; the four-force components tend to zero, etc. This clearly indicates, that all the relativistic quantities and expressions mentioned above cannot have an independent physical sense.

### The Maxwell equations

The following brief comment concerns the Maxwell equations (their conventional present form). Recall that they were obtained by generalization of experimental facts (phenomenologically) at low velocities (by analogy with the hydrodynamics). Therefore, it should not be expected that these equations were guessed in the final form. Maxwell's equations (or the wave equation) define the phase velocity, whereas the theory of relativity "pretends" to the maximum signal velocity (a group velocity). Actually, since some specific light is used always, the quantity  $c$  must be marked off some index: instead of  $c$  we can write the parametric dependence  $c(\omega)$ , and the wave equation will then be the equation for the Fourier-harmonics.

Since modern apologists of relativism abandoned the visualization and the principal necessity of medium's models for the light propagation, the way of generalization of Maxwell's equation becomes not uniquely defined even for the "absolute emptiness" in the case of non-monochromatic light, not to mention the passage to real non-linear media (including properties of "intermolecular emptiness", mechanisms of absorption and the light reradiation by molecules etc.). From pure mathematical considerations and without physical principles, such generalizations can be introduced as much as you desire, and all of them are equal in rights. The requirement that these equations be invariant with respect to transformations of coordinates and time is rather vacillating: the fields and equations for them can be introduced in many ways, if only the measured effects of these fields correspond to the values really observed in the experiment. So, for instance, it was shown in [81] that there exist non-local transformations of fields which retain the Maxwell equations with invariable time. It was shown in [14] that non-linear and non-local transformations can be introduced, so that for some particular transformations of fields, the field equations are invariant with respect to the Galilean transformations. The invariance of Maxwell's equations with respect to conformal transformations is also known [163].

A little history. The first invariant transformations for Maxwell's equations (and the wave equation) were found by V. Focht [172]. They looked like this:

$$x' = x - vt, \quad y' = y/Q(v), \quad z' = z/Q(v), \quad t' = t - xv/c^2;$$

$$Q = \frac{1}{\sqrt{1 - v^2/c^2}}.$$

Lorentz transformations in modern form were derived by Jo. Larmor ("Ether and Matter", 1900), and later by H. Lorentz and A. Poincaré. Initially they looked like this:

$$x' = \eta(v)Q(v)(x - vt), \quad y' = \eta(v)y, \quad z' = \eta(v)z,$$

$$t' = \eta(v)Q(v)(t - xv/c^2),$$

where  $\eta(v)$  is an arbitrary function of speed, but then H. Lorentz and A. Einstein decided that the sequential application of direct and inverse transformations supposedly should not change anything (but what about “logic” with the subsequent twin paradox?!); and from these considerations  $\eta(v)\eta(-v) = 1$ , they arbitrarily equated  $\eta(v) = \eta(-v) = 1$ . There is no one-valued choice here. So, for example, in [162] the author makes a more logical choice: If you take as standards not a fixed ruler and the passage of time, but the characteristics of light, i.e.  $L(\nu)$  and  $t(\nu)$ , then their change due to the Doppler effect must be taken into account. He is choosing

$$\eta(v) = \sqrt{\frac{c+v}{c-v}},$$

as a result we have

$$\eta(v)Q(v) = \frac{1}{1-v/c},$$

but this is a purely classic multiplier! Firstly, it depends on the sign of the velocity (we are approaching or moving away). And, secondly, it takes into account the weakening of the effective force if we move away from the source of impact, and our speed is close to the speed of transmission of this (electromagnetic) impact, which should be obvious from common sense! So there is no trace of any uniqueness with the invariance of Maxwell’s equations (and the wave equation)!

Let us demonstrate the methodical contradiction of generally accepted transformations for the fields. Let there be two infinite non-charged parallel wires. Let the electrons in both wires move in the same direction at constant speed relative to a positively charged frame (i.e. we have equal current densities  $\mathbf{j}$ ). Then for the classical case, the quantity  $j dV = en(v_+ - v_-)dV$  in the expression for the field is an invariant, i.e. the field  $H_{\perp}$  and the effect of this field do not depend on the velocity of the system. But for the relativistic consideration, since  $\mathbf{E} = 0$ , we have  $H_{\perp} = H_{\perp}^0 / \sqrt{1 - v^2/c^2}$ , i.e. this field depends on the speed of motion of the observer. However, the following two cases are obviously equivalent:

(1) the system with velocity  $\mathbf{v}_{obs} = 0$ , i.e. the observer is in rest relative to the wires, but the electrons are moving at velocity  $\mathbf{v}$ , and  
 (2) the system is moving at velocity  $\mathbf{v}_{obs} = \mathbf{v}$ , i.e. the observer is in rest relative to the electrons, but the wires (with positive ions) is moving in the opposite direction at velocity  $\mathbf{v}$  (the same current). However the relativistic formula gives for these cases different values of  $H_{\perp}$  (and effects of the fields), which is absurd. Besides, the SRT description of transitions from one inertial system to another inertial system becomes fully inconsistent for non-neutral currents in the three-dimensional case (for beams of charged particles, for example).

Now we shall analyze the “principal” question on the invariance of the Maxwell equations, which is widely advertised in SRT. In the textbook [32], the following four equations in differential form belong to the system of fundamental equations of electrodynamics:

$$\text{rot}\mathbf{H} = \frac{4\pi}{c}\mathbf{j} + \frac{1}{c}\frac{\partial\mathbf{D}}{\partial t},$$

$$\text{rot}\mathbf{E} = -\frac{1}{c}\frac{\partial\mathbf{B}}{\partial t},$$

$$\text{div}\mathbf{D} = 4\pi\rho,$$

$$\text{div}\mathbf{B} = 0.$$

However, this system of eight equations in coordinate form is obviously insufficient to determine the 16 quantities (taking into account all components)  $\mathbf{E}$ ,  $\mathbf{D}$ ,  $\mathbf{B}$ ,  $\mathbf{H}$ ,  $\mathbf{j}$  and  $\rho$ . It is also necessary to introduce the characteristics of the medium into the equations. Taking into account the existence of nonlinear, inhomogeneous, non-isotropic media, it is not possible to do this in a general form. Only within certain limits, it is possible to introduce particular model representations of linear dependencies:

$$\mathbf{D} = \varepsilon\mathbf{E},$$

$$\mathbf{B} = \mu\mathbf{H},$$



$$\mathbf{j} = \lambda \mathbf{E}$$

and to add 9 more equations with three new unknown functions  $\varepsilon, \mu, \lambda$  (or constant – for model problems), characterizing the medium. There can be no talk of a unified general invariance of the last three equations. Recall, for example, the existence of ferromagnets and ferroelectrics, for which hysteresis phenomena are observed, that is, the course of the process depends on its prehistory. In the latter cases, the behavior is not described by differential equations at all. Is it possible to “inflate the SRT bubble” only on the invariance of a part of the complete system of equations? Obviously not! Then, in an analogous manner, it would be possible to select arbitrary pieces from any equation and speculate on the invariance of these terms. In addition, Lorentz transformations (hyperbolic rotation) change the relationship between the angles, therefore, the change in the shape of complex boundaries must be taken into account when switching between moving frames of reference. Thus, the complete system of Maxwell’s equations in arbitrary media cannot be invariant with respect to some single physical transformation.

The first four equations can be of independent interest only when considering fields in a vacuum. However the invariance of the Maxwell equations with respect to the Lorentz transformations implies nothing for the other phenomena. First, the Maxwell equations are the equations for fields in the empty space. In such a space we can cut off a half of a segment and increase it as much as twice – then we obtain the same segment. Therefore, in the empty mathematical space one can make use of any frames of references, of self-consistent geometries and conversion factors. All these operations can be determined by the convenience of mathematical description only. However, we can not simply cut-through a living organism and increase it twice under a microscope – the organism will be dead. The presence of real physical bodies and fields in the space specifies natural reference points (“bench-marks”), characteristic scales and interrelations between the objects. All this determines the distinctions of a real physical space from the empty mathematical space. Second, the property of some interactions to propagate in vacuum

at the speed of light does not determine the rate of interactions' propagation in a medium. In spite of a drastic role of electromagnetic interactions, the disturbances in media propagate at the speed of sound. From one vacuum-related constant  $c$ , it is impossible to determine (for our "electromagnetic" world) the speeds of sound and light in gases, liquids and solid bodies. It is not clear, how the anisotropy of real solid bodies could arise in the isotropic space. All these and many other properties escape the limits of applicability of the Maxwell equations in the emptiness (the SRT, contrary, prescribes "cloning properties of emptiness" on all properties of material bodies and mediums). Therefore, the fitting of the properties of the entire world under the invariance of the Maxwell equations in emptiness is too excessive claim of SRT. Third, the partition of a single (in its effect) field into electrical and magnetic parts is rather conventional and, to a considerable extent, arbitrary. Hence, the invariance of these, artificially singled out parts can not have crucial significance. The presence of  $\rho, \epsilon, \mu$  coefficients (which depend on coordinates, time, properties of light, etc.) for the Maxwell equations in a medium makes these equations non-invariant relative to the Lorentz transformations (or is it necessary to cancel the objectivity of characteristics of media again?).

Important remark. By themselves, Maxwell's equations can acquire a physical meaning only after the physical method of measuring the introduced characteristics of fields is indicated. To date, such a "closing equation" is the equation of motion of charged particles under the action of the Lorentz force. Recall that in different periods of time, as an electromagnetic force, the Lorentz force was not the only one. Among the most famous expressions were: Ampere's force, Weber's force and many others. If modern electrodynamics had a self-consistent character, then, since the fields are manifested by their force action, the expression for the electromagnetic force would have to be derived from Maxwell's equations, and not introduced artificially. Such an expression was obtained in [149] and it differs from the expression for the Lorentz force. Can the expression for the Lorentz force be considered fundamentally rigorous

and consistent as an electromagnetic force? Apparently not! Although the achievements of modern electrodynamics are well known, some controversial points should also be noted [140]. First, even in modern electrodynamics, braking by radiation is additionally introduced, which, however, leads to a senseless spontaneous acceleration of charges (limited only postulately by imposing conditions on the magnitudes of the fields). Second, the very emergence of quantum mechanics [139] suggests that the Lorentz force does not adequately describe the behavior of charges on atomic scales. Thirdly, for the well-known particle drift phenomenon, it is somewhat strange that its velocity

$$\mathbf{v} = c \frac{[\mathbf{E} \times \mathbf{H}]}{H^2}$$

turns out to be independent of the magnitudes of the charge, mass, and the magnitudes of the fields themselves, but depends only on the ratio of the magnitudes of the fields  $E/H$ . Thus, the system of differential equations of modern electrodynamics and its representations cannot be considered as fundamentally rigorous and completely self-consistent, capable of imposing restrictions on other branches of physics.

### **Additional remarks**

In the classical physics all concepts have a clearly definite sense, and they should not be replaced with surrogates. May the relativists be inventing other names to their new concepts (or, more correctly to combinations of symbols)! The relativistic definition of coordinates of the center of inertia [17]:

$$\mathbf{R} = \frac{\sum E\mathbf{r}}{\sum E}$$

has no physical sense, since in SRT, the center of inertia for the same system of moving particles occurs to be different in various frames of reference. Therefore, it does not fulfill its functional designation of the center of equilibrium. Let we have a massive planar box, in

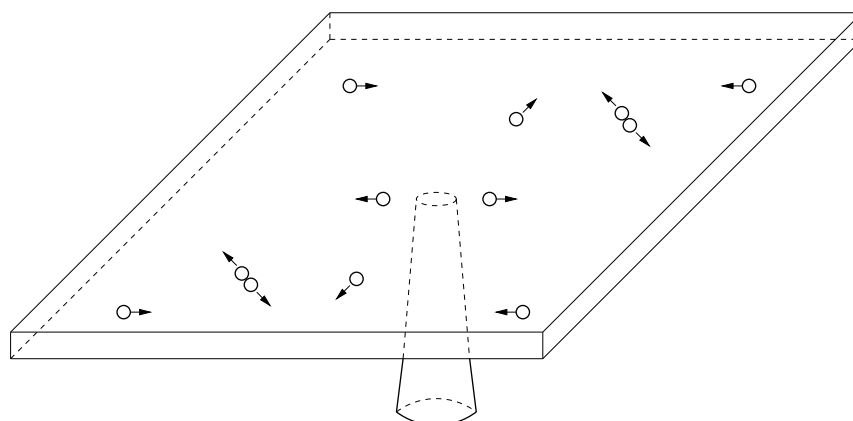

Figure 4.3: Center of inertia and equilibrium.

which the massive balls are moving. Let in the classical case, the center of inertia of the whole system (in the course of motion and collisions of balls) be always coinciding with the center of a box. Then in the classical case, we can balance it (for example, in the Earth's field of gravity or in some other field) on a support of small cross section (Fig. 4.3), and the equilibrium will be kept. In SRT, on the opposite, if we only shall look at this system from a rapidly moving relativistic missile, then the center of inertia can appear to be not above a support, and the equilibrium will be violated. A remarkable objectivity of SRT: in order that the equilibrium of plasma in a controlled thermonuclear fusion not be disturbed, we ask the relativistic missiles not to fly and not to "spy" upon the experiment. (Here, it turns out, why the thermonuclear fusion became an unbearable "black hole" - all sorts of things flew around here!)

The relativistic bond of the mass and energy actually reflects no principal thing. Indeed, the classical expression for kinetic energy  $E = mv^2/2$  and the relativistic expression  $E = mc^2((1 - v^2/c^2)^{-1/2} - 1)$  do not differ in any (qualitatively) significant thing. Both these quantities are calculated quantities. The attempt to mea-

sure these quantities (that is, the calibration of an instrument) depends on interpretation of the theory, since these quantities can not be determined from the comparison with a measurement standard. Since the relativistic expression of energy  $E = mc^2/\sqrt{1 - v^2/c^2}$  includes, except the mass, the other quantities, then for any possible interrelations, the mass and energy will remain as different quantities, nonequivalent and independent. Even for the so-called “energy of rest”  $E = mc^2$  the question can not be about mutual transformations of mass and energy. The fact is, that at annihilation (the only “candidate” for a similar process), the photons are generated, for which the “mass of motion” is postulated in SRT according to the same formula. Therefore, in this case the question is simply about mutual transformations of particles too. To say nothing of the fact, that the “energy of rest” is only the hypothesis of SRT, because the theory leads again to the same indeterminate constant, as in the classical physics.

We call attention to a non-invariance of the formula  $E = mc^2$  in the framework of SRT: mass is invariant, light speed is also invariant; however, energy represents by itself a four-vector. If the kinetic energy of molecules, which move with different velocities  $\mathbf{v}_i$ , is included in the full energy of a body, then these velocities will be added up in different manner with the velocity of the body as a whole in other moving systems. As the result, the relationship will be violated and in new system, this formula will be simple some relativistic definition for some “letter  $E$ ”.

SRT tries to fight, from principal grounds, “against the wind-mills”: for example, against the notion of absolute rigid body. In the classical physics, however, nobody assigns a literal sense in the abstraction of absolutely rigid body. It is obvious for everybody, that there are no absolutely rigid bodies even at absolutely non-relativistic velocities (we shall mention the role of accelerations, or, more correctly, of forces, in this issue by remembering usual collisions of cars on roads). Simply, in describing some motions, the influence of strains is negligible or unessential for the phenomenon under study, and then, only for the sake of simplifying mathemat-

ical derivations, the absolutely rigid body abstraction is applied. SRT principally tries to consider elementary particles to be points [17] and immediately encounters another principal problem – the singularity of some quantities.

Now we shall directly pass to remarks on relativistic dynamics (on the theory of collisions and laws of motion of charged particles).

### 4.3 Criticism of the conventional interpretation of relativistic dynamics

As a preliminary, to avoid a series of misunderstandings some comments should be made in respect to relativistic mechanics. First, confirmation within experimental accuracy for the laws of motion (the observable final results) cannot be considered as justification of all the methods used to obtain these results. In a scientific theory final results as well as starting principles and intermediate methods must all themselves be true as such! Second, arguing SRT's basic notions of space and time to be erroneous in no way implies a return to static forces of classical mechanics for the description of real particle motions. These two theories are not interrelated in any way. Classical mechanics is a model theory; it assumes bodies to be absolutely solid, impact of two material points (actually – two absolutely solid elastic spheres, whose radii tend to zero in the limit) to be absolutely elastic; kinetic energy and momentum to be fully “concentrated” in the motion of a body as a whole, and the exchange of energy and momentum to occur instantaneously. Neither classical mechanics nor relativity theory investigates the processes inside colliding particles; the only additional question about the rate of transmission of interactions appears at high velocities (about accounting finiteness of this rate).

Naturally, the taking account of a finite time for propagation and transmission of interactions results in a change of the observed motion of particles. An additional dependence of quantities on velocity appears; for example, in an effective mass (more precisely

for the effective force). This can be qualitatively understood from the following elementary mechanical model. Let us consider one-dimensional motion. Let a source constantly and uniformly emit identical particles flying with some constant speed  $v_1$  along some straight line. Being placed at any point of the straight line, a sample body at rest will undergo action of a constant pressure force (from bombarding particles). If now it is permissible for the sample body to move in the direction away from the source at some velocity  $\mathbf{V}$ , then the number of particles reaching this body per time unit will decrease. The factor taking this effect into account at the achieved speed  $V$  will be the following:

$$\frac{1}{1 - V/v_1}.$$

This can be interpreted as a decrease in the effective force during motion or an increase in the effective mass. This effect is a strict quantity without any approximate expansions! It can be experimentally measured in a very wide range of speeds  $V$  and  $v_1$ . It would seem that since the theory of relativity claims a completely different effect (caused by completely different reasons), then first it would be necessary to take into account this everywhere observed “mechanical” effect and explain not all the supposedly relativistic change in the value, but only the difference (!) between the observed change and the mentioned classical effect. So here the relativists clearly “got greedy and grabbed what was extra”. In transition to the limit  $V \rightarrow v_1$ , when a free test body accelerates under the action of these particles, the effective mass in this mechanical experiment tends to infinity (it would be more correct to say that the effective force tends to zero).

Certainly, it is impossible to deduce quantitative dependences from this classical mechanistic model, because the collisions themselves cannot be considered as absolutely elastic and instantaneous. Recall only that there exists the classical Lorentz model (a deformable sphere), which describes the dynamics of an electron ( $m_{\perp}$  and  $m_{\parallel}$ ). The classical equation of motion for particles can also be

obtained considering non-locality or non-linearity [14,15,81]. Relativistic effects can be also obtained by assuming changes in the effective charge. The aim of this book does not include the analysis of all possible alternative methods for development of mechanics, or the choice between these methods.

Now we shall directly proceed to the relativistic dynamics. SRT is completely inconsistent in considering accelerations and the dynamics of particles in general. The Lorentz transformations (from which the entire SRT follows) cannot impose any limitations on accelerations of bodies (as well as on studying accelerated systems). However, in such a case some SRT mismatches with the experiment would become too noticeable. As a result, SRT artificially declares that the study of accelerated (non-inertial) systems is a prerogative of GRT. But the successive application of this declaration would remain from SRT only the Lorentz transformations themselves and the velocity addition law (that is, a part of kinematics). To rise the “significance” of the theory, at first, in SRT the 4-acceleration is calculated formally mathematically, and then the relativistic dynamic equations are formally “derived”. But what about the transformation of forces? In this case, contrary to SRT’s own declaration, it is necessary to transform one accelerated particle (for  $v \neq 0$ ) into “another” accelerated particle (for  $v = 0$ ). The transformation of electromagnetic fields also contradicts the declared self-limitations, since the fields, introduced in a conventional manner, reflect nothing but the action of electromagnetic forces (the force approach). It would seem that the declaring of equivalence of SRT and GRT approaches could rise the “significance” of the theory. However, in some problems, the application of SRT and GRT leads to different quantitative results. These mismatches result in the necessity of sacrificing any of the relativistic theories (or, more correctly, both of them).



### On “confirmation” of the SRT conservation laws

Confirmations of SRT by the nuclear physics and elementary particle physics are not so unambiguous, as the relativists believe. Note that one equation (equality) can check no more than one dependence between physical quantities (remember Poincare). Moreover, all the physical quantities included in this equation must be independently determined in advance, otherwise it will be not a law, but a postulative definition of some unmeasured quantity. Whether the relativistic conservation laws are confirmed? The properties of a new particle are often simply postulated; for example, in formation or participation of neutral particles they are always postulated. May be, that’s why so many particles were “arisen” (to cover the dress of the “naked king”)? Let us consider in detail the reaction from the book [33] analyzed in order to demonstrate the “possibilities” of SRT:

$$H^2(\text{rapid}) + H^2(\text{resting}) \rightarrow H^1 + H^3.$$

Even for such a “demonstration” reaction (where, it would seem, all quantities must be measured and all balances must be agreed), it turns out that:

- 1) it is impossible to measure kinetic energies of all participating particles; therefore, the energy conservation law was not verified;
- 2) in the full energy-momentum balance, several SRT equations participate, which have not be (a priori) verified yet (as a result, the quantities to be verified become simply postulated);
- 3) in the momenta balance expression, the momenta have to be artificially separated in directions, and there is no warranty that separated particles belong to the same act of interaction (and that they are still not different in the place and time of formation);
- 4) there are also no tolerances for particles’ dispersion angles, which makes doubtful the relative accuracy of  $2 \cdot 10^{-6}$  indicated in the book (so, even the deuteron energy was measured only to the relative accuracy of  $10^{-3}$ !);
- 5) the process of any collision itself, for large particles’ dispersion angles especially, represents the accelerated motion of charged par-

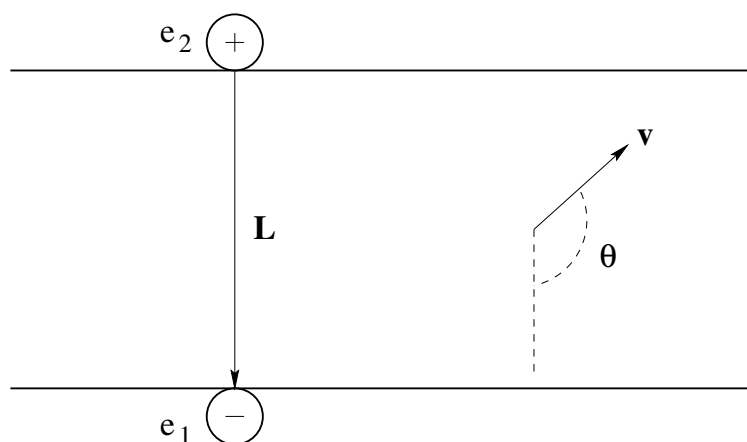

Figure 4.4: Paradox of transformation of forces.

ticles. Therefore, according to the modern views, some radiation should always be observed. However, except the cases of direct recording gamma-quanta, the accounting of the energy and momentum of arising field is not encountered anywhere. Thus, the balance in the conservation laws is not verified. Simply, such a value is assigned (postulated) to the quantities not measured independently, that no contradictions with SRT would arise. And SRT tries to prolong this continuous chain of postulations up to infinity.

### Some relativistic solutions and corollaries

Consider now a paradox of transformation of forces. Let we have two charges  $e_1$  and  $e_2$  of opposite sign, which are at rest and separated by two parallel planes being at distance  $L$  apart of each other (see Fig. 4.4). Owing to attraction to each other, the charges are at a minimum distance  $L$  from one another. (They are at the state of neutral equilibrium with respect to a system of planes.) We shall draw a mark on a plane under each charge, or we shall place the observers nearby. Now we shall observe this system of charges from a

relativistic missile moving at velocity  $\mathbf{v}$ . Let  $\theta$  be the angle between vectors  $\mathbf{v}$  and  $\mathbf{L}$ . Determining the electromagnetic forces, acting between these charges in missile's frame of reference [17], we shall be interested in tangential components of forces, i.e. in the components of forces along the planes. The force influencing charge  $e_1$  is

$$F_\tau = \frac{e_1 e_2 (1 - v^2/c^2)(v^2/c^2) \sin \theta \cos \theta}{L^2 (1 - v^2 \sin^2 \theta/c^2)^{3/2}} \neq 0. \quad (4.1)$$

Therefore, the charges will be displaced from their initial position. Let the balls be having huge charges,  $L$  be small ( $L \rightarrow 0$ ), and  $v$  be large ( $v \rightarrow c$ ). Let the observers to retain the balls with very thin threads. Whether they will be torn? The answer depends on the system of observation. So, who of the observers will be right? Thus, we have another inconsistency of SRT.

Let us consider now some particular problems. Methodically paradoxical is the description of motion of a charged  $e$  particle of mass  $m_0$  in a constant uniform electric field  $E_x = E$  (see [34]). Really, in the classical physics the trajectory for  $v_y = v_0$  is a parabola:

$$x = eEy^2/(2m_0v_0^2),$$

and in SRT it is the chain line:

$$x = \frac{m_0 c^2}{eE} \left( \cosh \left[ \frac{eEy}{m_0 v_0 c} \right] - 1 \right).$$

But for large  $y$  values the relativistic trajectory is close to an exponential curve, i.e. it is steeper, than parabola. But what in this case we should do with the idea on increasing the inertia (mass) of a body with the velocity? Even if we suppose that, despite a slightly greater steepness, the particle is slower moving over the trajectory, then due to which forces it has been slowed down over axis  $y$ ? Since the force  $F_y = 0$ , then it will not appear in SRT as well:  $F'_y = 0$ . And the initial velocity value  $v_y = v_0$  can be non-relativistic (and will remain the same).

The energy balance for a relativistic missile is strange [33]:

$$m \cosh \theta + M_2 \cosh(d\theta) = M_1.$$

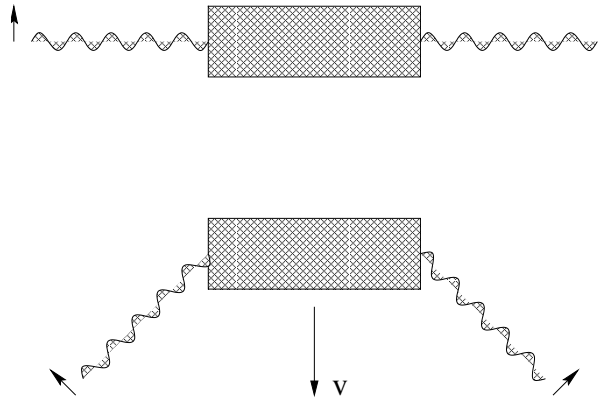

Figure 4.5: To the derivation of the formula  $E = mc^2$ .

At high ejection rate ( $\theta = \tanh(v/c)$ ) for finite values of initial  $M_1$  and final  $M_2$  masses, the following condition (for SRT consistency) should be fulfilled: the mass of a separate ejection  $m \rightarrow 0$ . However, this quantity is determined by technological design of the rocket only: there are no principal limitations.

One of derivations of Einstein's relation  $E = mc^2$  is insufficiently substantiated. In this derivation, the process of absorption of two symmetrical light pulses by a body is considered from the viewpoint of two observers moving relative to each other. The first observer is resting relative to a body and the second one is moving perpendicular to the light (Fig. 4.5). It occurs in SRT that the light should "know" beforehand about observer's motion at velocity  $v$  exactly, and the momentum should be received in such a manner, that in this second system the velocity of a body be not changed, but only its mass must change. But in such a case what shall we do with Lebedev's experiments (and to the present conventional concepts) on light pressure, where at momentum transmission by light, it is the observed velocity of a body, which is changed? And what will happen to the momentum, if we shall have absolutely absorbing rough (skewed) surfaces? It is also unclear from presented draw-

ings, whether we are dealing with real transversal light (the model, which now is conventional, including in the SRT as well) or with some mystical longitudinal-transversal light (for “saving” SRT).

In the modern version of SRT, rather strange is the difference in the mass of the total radiation as a dependence on system’s momentum:

$$m = \sqrt{\frac{(E_1 + E_2)^2}{c^4} - \frac{(\mathbf{P}_1 + \mathbf{P}_2)^2}{c^2}}. \quad (4.2)$$

And if we shall change the momentum (direction) of separate photons by mirrors? In this case we shall determine the center of gravitation of a system. Where will it be localized also what will be the structure of the field closely to it? Will this center be skipping, disappearing and reappearing, really? Let us make use of presented SRT formula (4.2) for determining the mass of cumulative radiation of two photons, flying apart of each other at arbitrary angle, and consider the radiation diverging from the same center (see Fig. 4.6). Then, depending on the in-pair grouping of photons, we can obtain different cumulative mass of the whole system (whether will it be necessary to introduce artificially the negative masses for “explaining” all possible variations of a mass?). And in GRT it is necessary to take into account the radiation birth prehistory for determining the localization of its center of gravitation and, besides, to take into account the whole unknown space-time structure of the electromagnetic field for correct description of quite different a phenomenon – the gravitation. Infinitely complicated procedure, really! And in the name of what is all this?!

### Spin and the Thomas precession

The relativists permanently emphasize that the Newtonian mechanics does not describe some things as compared to SRT. For example, the so-called Thomas precession is considered in the book [33] (which represents the effect of turning a rod as the manifestation of the “relativity of simultaneity” in SRT). It is also alleged in this book that in the Newtonian mechanics, the gyroscope always keeps

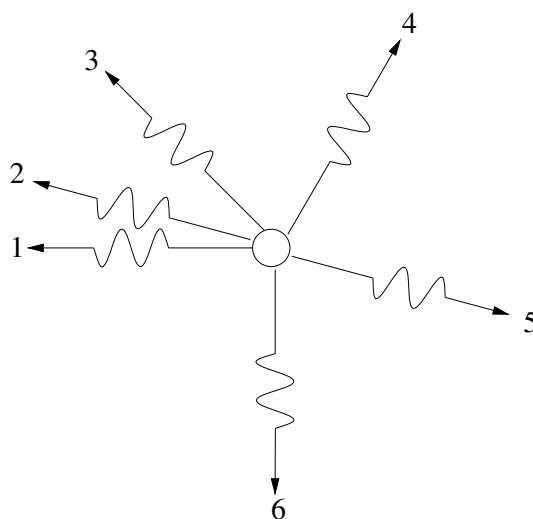

Figure 4.6: A mass of the photon combination.

its orientation. However, as known from the quantum mechanics, the electron spin moment is always directed either along, or against the direction of orbital moment. That is, in the given case, the electron spin moment is directed perpendicular to the orbital plane and is perpendicular to the electron velocity! But in this generally accepted case, both the Newtonian mechanics and SRT conserve the gyroscope direction perpendicular to the orbital plane. Therefore, the changing spin directions, depicted in the book [33], do not correspond to reality (Fig. 4.7). If, nevertheless, we suppose that the electron spin orientation is slant, but recall, that we have not simply a gyroscope (a rotating ball), but a charged particle that possesses magnetic moment, then in the magnetic field of a charged nucleus, under an effect of forces, the electron spin precession will be observed, which can be described in the classical manner (as far as it is possible to be done for objects of micro world). For classical description of the given phenomenon (without SRT interpretations), it is necessary to know all atomic parameters, including the orienta-

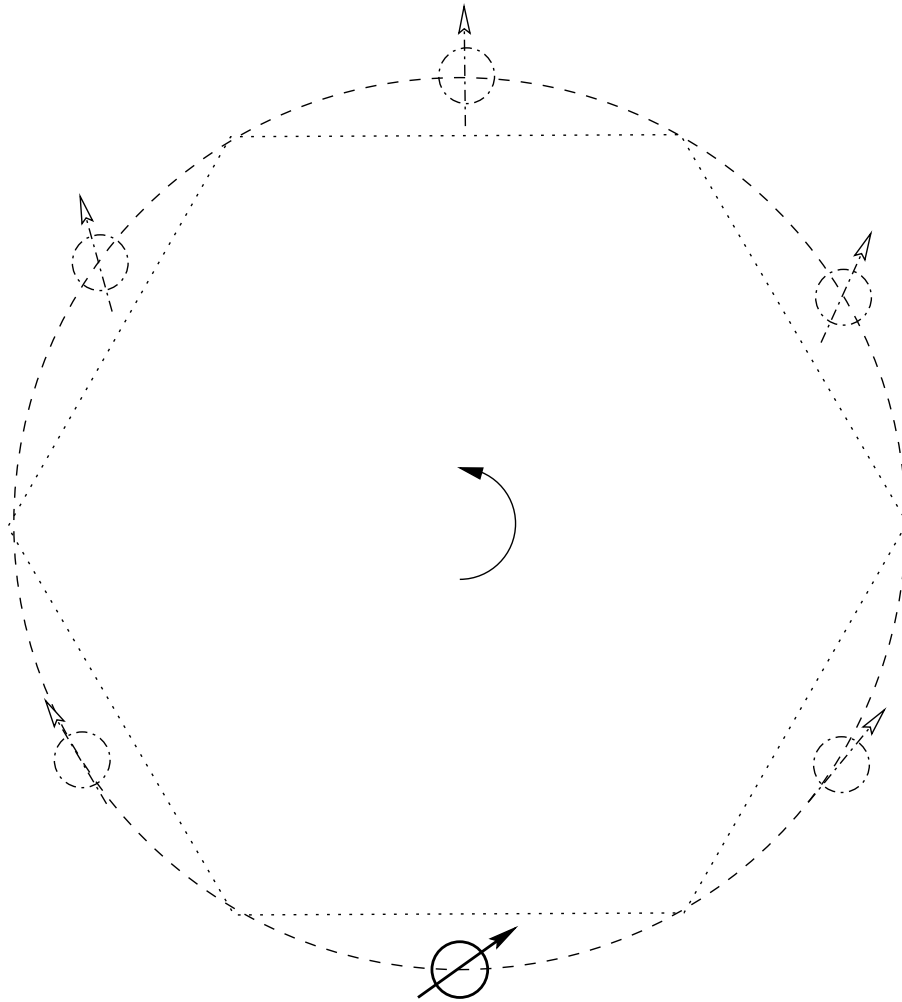

Figure 4.7: The Thomas precession in SRT.

tions of spins and moments. Moreover, in the classical case, even if the electron spin orientation is perpendicular to the orbit, the precession is possible, if the nucleus moment is not perpendicular to the orbit (the nucleus can precess too). In a real many-body problem, there occurs always a coordination of all movements, including the coordination of all orbits, all precessions and displacements of all perihelia.

The modern use of the concept of a particle spin in SRT is internally inconsistent. The fact is, that at collisions the particles move relative to each other and, in addition, change their motion. But in a moving system the angular momentum (both the orbital momentum and the spin) must, according to SRT, differ from the previous quantity in a resting system. How can the spin remain invariant and participate in rigorous numerical equalities (in relativistic conservation laws)?

Besides, the Thomas precession as a kinematic effect of SRT is internally contradictory (see Chapter 1), since this rotation process is beyond the scope of SRT inertial systems (of rectilinear uniform motion).

### Once again on mass

The law of conservation of mass, as an independent law, is confirmed by a vast amount of the experimental data. The elementary particles either do not change at all (but change their kinetic energy and the energy of their concordant electromagnetic field), or completely transform into the other particles. The photon is also a particle, which can be characterized by the velocity and frequency or by the wavelength. No arbitrary transformations of mass into energy do exist at all.

Still remain in SRT the questions for particles with a zero rest mass. First, a rigorous transition to the case of  $v = c, m_0 = 0$  follows from relativistic expressions for energy and momentum in no way. How, for example, can arise a continuum of every possible frequencies  $\omega$  in such a transition? Second, where do the gravitation



energy (field) and the bending of space disappear (and where is their center of localization positioned at annihilation), if we have a linear chain of sequentially annihilating and born pairs, or in the case, where from  $m_0 \neq 0$  we obtain, by means of reflections,  $m_0 = 0$ ? Generally speaking, the problem of photon's rest mass is senseless in the modern interpretation. The photon – as a definite particle – is characterized by some definite frequency  $\omega$ . At rest ( $\omega = 0$ ), the photon would even be not a different particle; it would simply cease to exist. Therefore, there is no concept itself of photon's rest mass (as well as the concept of photon's rest energy, etc.). On the other hand, for a real photon it is quite possible to determine not only the energy and momentum, but the mass as well. In the textbook [26], the conclusion was drawn quite incorrectly, that the particles with zero rest mass can not exist in the classical physics, since for  $m = 0$ , any force must allegedly cause infinite acceleration. First, not arbitrary force can act on a photon with  $m = 0$ . For example, when the gravitation force acts, zero masses are correctly “canceled” and the acceleration remains finite. Second, both the classical mechanics and SRT do not impose principal limitations on the value of acceleration. This allows one, for example, to consider the collisions of particles and the reflection of light to be instantaneous processes. Third, why the SRT choice is better, when under an effect of force, according to relativists' logic, the acceleration for light remains to be zero? If we appeal to intuition, then the infinite photon mass is obtained in SRT.

The field (possibly, not only electromagnetic?), as a material medium capable of transferring energy and possessing a momentum, can possess a mass as well (such a concept is inner consistent, but only an experiment can give an answer – whether this possibility is realized or not). Hence, for the classical physics, it is also not surprising at all, that some field is capable to transfer the mass. In such a case, the field must participate in the classical mass conservation law, and then the mass will be conserved in any reactions. The field must also participate in the momentum and energy conservation laws, and then one can maintain (not changeable) the classical

part of these conservation laws, which relates to particles. Therefore, in the classical physics, it is also not surprising at all, that the excited atom can weigh greater than unexcited one, or the body with a greater energy can possess greater mass (by the way, with modern measurement accuracy, this fact cannot be verified). This additional mass is concentrated in the field, which causes particles to oscillate, to move over forceless trajectories or to kick from a particle-retaining wall. If we suppose the particles and the process of their collision itself to possess a purely electromagnetic nature, then in vacuum, it is possible to use the relativistic expressions for the momentum-energy, but only from the viewpoint of unambiguous interrelations between quantities. However, one should remember here, that in this case, the energy and momentum characterize the given collision process only, because they are written down, actually, with implicit allowance for the energy and momentum of the field (without explicit accounting and separating field terms).

### **The theory of collisions and the conservation laws in SRT**

Very frequently in SRT, for “simplifying” the description of collisions, the technique of transition to some “conveniently moving” frame of reference is used. Such a procedure, however, has no physical grounds, and the principle of relativity for isolated identical systems is for nothing here at all. If the relativistic experiments are carried out with artificial beams of particles, then the sources (accelerators) and recording instruments are bound to the Earth, and accelerators and instruments will not fly, together with a moving observer, from our mental imagination only. If some process in Wilson’s chamber is investigated, then the tracks of particles are bound to a medium (that is, to Wilson’s chamber), rather than to a flying observer. For example, in the classical physics, the angle between the tracks of particles will not change due to motion of an observer. At the same time, the angle between the velocities of particles, which leave mentioned tracks, can depend on observer’s

motion velocity. In the relativistic physics, the angles between trajectories and between velocities of particles depend also according to various (other) laws on observer's motion velocity. Therefore, such a seemingly probable from SRT viewpoint transition to a new frame of reference can essentially distort the interpretation of a solution. That is, any process should be considered in the frame of reference of a real observer (recording instrument) only.

One more distortion of reality is the consideration of the process of collision for two particles (which are principally point-like in SRT) as a planar motion. In fact, even in studies of statistical characteristics of point particles, to fit to an ideal problem of two points, a measuring device cannot simultaneously fly with each pair of particles and differently rotate: the position of the device is fixed. Besides, point-like particles should be considered as a limiting case of particles having real finite size (otherwise no frontal collisions would be observed, it would be impossible to consider collisions of atoms and molecules, the protons would not have structure, etc.). But in the present case the collision of particles is principally three-dimensional (the probability of planar motion is zero). Let, for example, two identical balls (1 and 2) to approach each other before collision over straight lines, which are not intersecting and not parallel in space, so that the minimum distance between these skew lines is smaller than the ball diameter. Even from the very beginning of the experiment, we cannot draw the plane through these specified straight lines. Nevertheless, we shall take the middle of a minimum distance between our skew straight lines (the trajectories before collision) and draw intersecting straight lines parallel to the given trajectories through this middle. Now, only one plane  $\alpha$  passes through these intersecting straight lines (Fig. 4.8). The centers of the balls move parallel to this plane before collision: the first ball's center moves slightly above the plane and the second ball's center – slightly below this plane. After collision, the balls will fly in other skew straight lines (not intersecting and not parallel). And, again, it is impossible to draw the plane through these skew straight lines. Again, we shall perform a similar procedure with parallel transi-

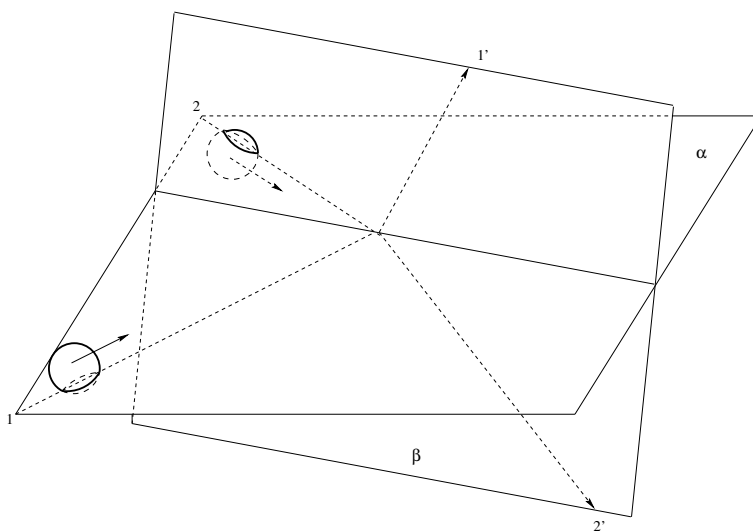

Figure 4.8: Nonplanar motion of two particles.

tion of straight lines, on which the lines of motion lie after collision, before intersecting at the middle. We shall draw through new intersecting straight lines the plane  $\beta$ ; the centers of balls will again lie (and move) on different sides from this plane. However, “the plane before collision” does not coincide with “the plane after collision”, but intersects it at some angle.

Second method: let us draw one plane  $\gamma$  through the trajectory of motion of the first particle (which consist of intersecting straight lines of its motion before and after collision), and the second plane  $\delta$  – through a similar trajectory of motion of the second particle. However, these planes are also intersected at some angle (Fig. 4.9).

So, what follows from three-dimensionality of motion? First: not all relations turn out linear ones. For example, the distance between bodies occurs some nonlinear function of time even for the rectilinear uniform motion of the bodies along skew (not intersecting

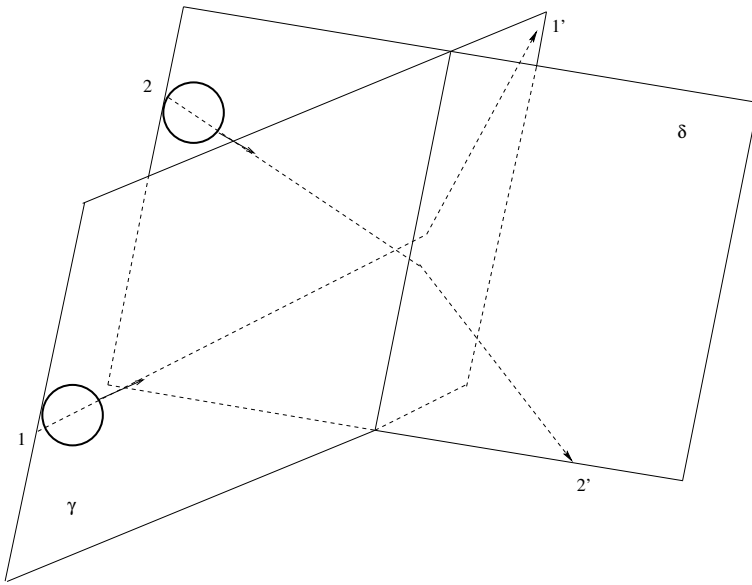

Figure 4.9: Three-dimensionality of collision of two particles.

and not parallel) lines. Second: we shall write the classical laws of conservation of momentum (in projections) and of energy:

$$v_{1x} + v_{2x} = v'_{1x} + v'_{2x} \quad (4.3)$$

$$v_{1y} + v_{2y} = v'_{1y} + v'_{2y} \quad (4.4)$$

$$v_{1z} + v_{2z} = v'_{1z} + v'_{2z} \quad (4.5)$$

$$\sum_{i=1,2} (v_{ix}^2 + v_{iy}^2 + v_{iz}^2) = \sum_{i=1,2} (v'_{ix}{}^2 + v'_{iy}{}^2 + v'_{iz}{}^2). \quad (4.6)$$

We see from (4.3-4.6), that for six unknown quantities ( $v'_{1x}, v'_{1y}, v'_{1z}, v'_{2x}, v'_{2y}, v'_{2z}$ ), there are four equations only. Thus, there should remain two indefinite parameters in the solution. But if we suppose the motion to be planar (i.e. exclude equation (4.5)), then for remaining four unknowns, we shall have three equations. Therefore, in comparing SRT results with the classical physics, the fraudulent substitution of solutions is accomplished, and there remains only one indefinite parameter (the scattering angle is usually considered to be the latter one). Such a substitution results in improper interpretation of the experimental data, especially when the missed quantities are restored. For example, the book [33] demonstrates two tracks of fly-away of particles of identical mass and charge (more correctly, of identical  $e/m$  ratio) with dispersion angle lower than  $90^\circ$ , and the conclusion on the classical mechanics invalidity is drawn from this demonstration. Let us write the expression for angle  $\alpha$  between the trajectories of dispersed particles:

$$\cos \alpha = \frac{v'_{1x} v'_{2x} + v'_{1y} v'_{2y} + v'_{1z} v'_{2z}}{\sqrt{(v'_{1x}{}^2 + v'_{1y}{}^2 + v'_{1z}{}^2)(v'_{2x}{}^2 + v'_{2y}{}^2 + v'_{2z}{}^2)}}. \quad (4.7)$$

We choose axis  $Z$  so, that it will be  $v_{1z} = v_{2z} = 0$ . Now we express variable  $v'_{1x}$  from equation (4.3), variable  $v'_{1y}$  – from equation (4.4), variable  $v'_{1z}$  – from equation (4.5), and from equation (4.6) we shall express quantity  $v'_{2z}{}^2$  (in this case the condition  $v'_{2z}{}^2 > 0$  restricts the region of possible values of all variables). Substitute all aforementioned quantities into equation (4.7). As a result, we

obtain the two-parametric dependence on  $v'_{2x}$  and  $v'_{2y}$ , which is not written here because of its awkwardness. Using graphical programs, we can be convinced that for the given values of  $v_{1x}, v_{1y}, v_{2x}, v_{2y}$ , we obtain some surface similar to the inner part of a cylinder; that is, quantity  $\cos \alpha$  varies within wide limits. For example, it can easily be verified that the values

$$v_{1x} = 0, 1; \quad v_{1y} = 0, 1; \quad v_{2x} = 0, 7; \quad v_{2y} = 0, 7; \quad v'_{1x} = 0, 6;$$

$$v'_{2x} = 0, 2; \quad v'_{1y} = 0, 4; \quad v'_{2y} = 0, 4; \quad -v'_{2z} = v'_{1z} = \sqrt{0, 14}$$

satisfy all classical conservation laws (4.3-4.6). For these values we obtain  $\cos \alpha = 0.29554$ , that is,  $\alpha \approx 72.8^\circ$ . Note, if the velocities are assumed to be expressed in units of the speed of light, then a lower velocity is quite real for the motion of internal electrons in atoms beginning with  $z \geq 60$ . And in the general case, nobody saw resting electrons in atoms! The angle of  $90^\circ$  is unambiguously obtained in the classical physics at collision with a particle being at rest in the coordinate system of a recorder (but only where such a particle can be found?). However, the observed fly-away angle of  $90^\circ$  does not unambiguously result at all in an opposite assertion, that one of particles had been at rest (the mathematical probability of such an event is infinitesimal). Thus, the reverse problem of restoring the missed data is not an unambiguous procedure either in the classical, or in the relativistic physics (there exists an infinite number of various self-consistent solutions).

For more rigorous verification of conservation laws in collisions (independent of any theory), it is necessary to study collisions of particles in vacuum for narrow monoenergetic beams of known particles for the given collision angles. In this case, the complete study of the collision process should include the check of the energy balance of particles (for each scattering angle in space), the testing the balance of momenta of particles, the testing the balance of the total number of particles in beams before and after collision (the probability of scattering), the control of the balance of arising radiation in energies and directions. There are two more questions (two more

uncertainties), which are not usually emphasized, namely: does the scattering depend on a mutual orientation of spins of colliding particles? And do these spins change during the collision? In the classical physics, the answer to these questions is “yes” (but in the quantitative respect it strongly depends on the “structure” of balls).

The author did not meet any complete analysis of any process of collisions in SRT with respect to all issues set forth above. This does not imply, however, an unambiguous conclusion on invalidity (within the limits of experimental errors) of usually utilized relativistic conservation laws in any collision process (though this can quite occur to be the fact for many separate cases). The author only asserts that there are no even separate examples of absolute confirmation of relativistic conservation laws (to say nothing of their advertised global confirmation).

From a principally rigorous position, the application of relativistic conservation laws to the collision process in the elementary particle physics is rather doubtful. Whether these laws can retain their form irrespective of the charge of colliding particles, collision angles and dispersion angles? You see, the charged particles undergo acceleration during the collision. Therefore, according to the modern concepts (to the SRT as well), some radiation (field) should always be observed. Is it necessary, really, to behave as the students having peeped at the answer to the problem: if the instrument has recorded a  $\gamma$ -quantum (“has seized our hand”), then it should be clearly taken into account “with a clever air”? Should we, however, trust in validity of SRT formulas “with a clever air” in remaining cases as well? So, where is the “predictive force” of SRT? Actually, the conservation laws should be explicitly supplemented by the terms, which take into account the energy and momentum of the field.

Generally speaking, the only case, where the discussion of relativistic conservation laws at “collisions” is lawful, is the interaction of particles with the forces of electromagnetic nature (the Lorentz force). For remaining cases, the fulfillment of the relativistic conservation laws is an unverified hypothesis (the light spheres of SRT



bear no relation to the forces of non-electromagnetic nature). However, even in the case of electromagnetic interactions, the derivation of the relativistic conservation laws does not require any SRT ideas at all. It is known that the equations of motion with the initial conditions completely determine all characteristics of motion, including the integrals of motion. Such an integral of motion can be the energy (but not always!). It follows from the equation of motion, that

$$\frac{d\mathbf{P}}{dt} = \mathbf{F} \Rightarrow \mathbf{v}d\mathbf{P} = \mathbf{F}d\mathbf{r}. \quad (4.8)$$

Introduce the definition of the potential energy

$$U = - \int_{r_0}^r \mathbf{F}d\mathbf{r}.$$

If we know the form of the momentum (this is a quantity appeared in the experimental equation of motion (4.8), for example, in the classical case  $\mathbf{P} = m\mathbf{v}$ , and in the relativistic case  $\mathbf{P} = m\mathbf{v}/\sqrt{1-v^2/c^2}$ ), then we can obtain the energy conservation law from  $dE = \mathbf{v}d\mathbf{P} - \mathbf{F}d\mathbf{r}$ : classical  $U + mv^2/2 = constant$ , or relativistic  $U + mc^2/\sqrt{1-v^2/c^2} = constant$ , respectively. Under the condition of equality forces of action and counteraction (the third Newton's law, the hypothesis of central forces) we have:  $\mathbf{F}_{12} = -\mathbf{F}_{21}$ . Then from the equation of motion (4.8) we can obtain the momentum conservation law (this is again a quantity appeared in the experimental equation of motion (4.8)): from  $d\mathbf{P}_1/dt = \mathbf{F}_{12}$ ,  $d\mathbf{P}_2/dt = \mathbf{F}_{21}$  we obtain

$$\frac{d(\mathbf{P}_1 + \mathbf{P}_2)}{dt} = 0, \Rightarrow \mathbf{P}_1 + \mathbf{P}_2 = constant.$$

However, in the presence of magnetic forces  $\mathbf{F}_{12} \neq -\mathbf{F}_{21}$ , and the relativistic law for conservation of momentum of particles can be violated in the general case. Since the majority of particles, even many electrically neutral ones, have magnetic moment (i.e. they represent not "ideal point charges of the SRT", but charged magnetic rotators of finite size), then the application of the relativistic

momentum conservation law in the nuclear physics and in the elementary particle physics is completely illegitimate without explicit considering the field momentum. Therefore, we again arrive at the necessity of explicit considering the momentum (and, hence, the energy) of the field at collisions. (Possibly, this will help to regulate the nuclear physics and elementary particle physics and to decrease the number of particles-ghosts?)

The account taken of the radiation reaction force also results in violation of energy and momentum conservation laws declared in SRT. Should we refuse from accounting this force in the process of collision of particles? But this force just should be most significant in this process (there are great fields, owing to rapprochement of high-energy particles, and great variable accelerations).

### The angular momentum in SRT

In the general case, the non-conservation of the generally-accepted expressions for relativistic energy and momentum at collisions of particles results also in the non-conservation of the angular momentum in SRT. However, the relativistic expression for the angular momentum can be easily discredited for much simpler examples [8]. Let us recall, for example, the paradox of a lever. Let two forces, equal in magnitude,  $F_1 = F_2 \equiv F$ , to act on two identical arms  $l_1 = l_2 \equiv l$ , disposed at angle  $\pi/2$  (Fig. 4.10). The total moment of forces equals zero. The structure remains motionless. In the classical physics the result does not depend at all on the frame of reference, and, hence, it is not necessary to invent any new physical concepts, processes, phenomena or mathematical derivations.

The situation in SRT is quite different. If somebody only cast a look at this system from a missile moving at velocity  $v$  along one of these lever arms, then the total moment will become to be nonzero. Owing to contraction of lengths and transformation of forces, we have:  $M_{sum} = Flv^2/c^2 \neq 0$ . The lever must begin to rotate. It would seem that such an inconsistency should entail the refusal from SRT and the return to the classical physics, which provides the ob-

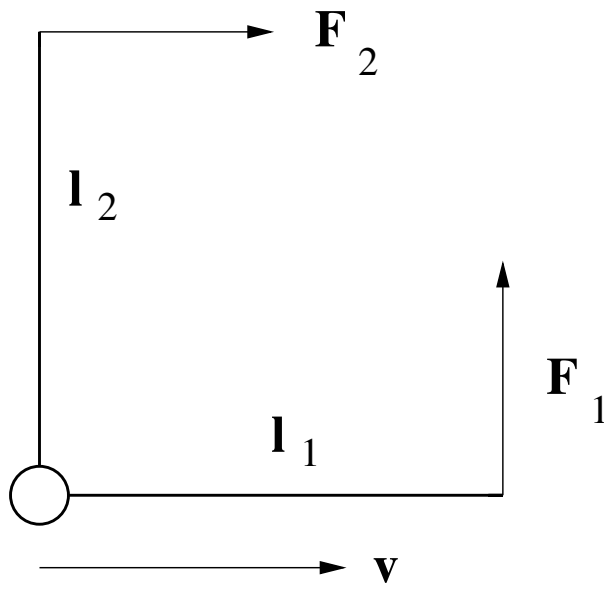

Figure 4.10: Paradox of a lever.

vious and true result. However, the relativists (following Laue and Sommerfeld) have gone another way [34]. “For the sake” of pseudo-science, it was necessary to sacrifice something. Since the common sense is less significant for relativists, than SRT, it was necessary for them to invent the missing pseudo-moment. Now, if you simply lean upon something (upon a wall, for instance) or use a lever, then you should stock up some additional clothes: “something” (the energy) will begin to flow through you, and this quantity can turn out huge! Besides, the fluxes (of sweat, probably) can simultaneously turn out to be different, if somebody “spies” on you from some differently moving missiles. If you keep both levers with your hands with identical force, then the energy from one hand merely flows away to an axis and “settles” somewhere. Do not worry, however! Such a “something” can not be measured in any way, and it has even no necessity for relativists: this is not to engage in physics, you see! Simply, the literal expressions must be coincide with the result obvious from the common sense viewpoint. Thus, instead of one relativistic effect, which cannot be measured in principle (otherwise the inconsistency would be detected), we obtained two relativistic effects, which are undetectable in principle and exactly compensating each other. Such tricks have the effect on many people (simply, because the letters coincide!), despite the fact that the “dry remainder” of all similar “inventions” – is the classical result known in advance.

### The Compton effect

There are also some questions to the Compton effect theory and, in particular, to the interpretation of two key facts of the experimental curve: 1) the scattering on free electrons being at rest; 2) the declaration of the presence of strongly (?) bound electrons at energies of incident hard X-rays greater than 1 Mev (!). For the first fact, one should make the following comment. First, at real temperatures, the possibility for an electron (even free) to have zero velocity is zero, and it is necessary to consider the arbitrary motion of electrons (the

real distribution). In particular, the peak should be related to the most probable, rather to zero, velocity (and for an atom – to the velocity of bounded electrons in the atom, which is rather great). Second, it would be interesting to confirm this effect with electron beams for all three quantities independently (the full balance): in angles, in energies and in a number of particles. On the second fact, we note that at the declared high energies, it would be strange not to pull out an arbitrary electron (even the internal one). Possibly, the Compton effect (as well as Mossbauer's effect) should be considered for a body (or atom) as whole from some resonance conditions (with regard to concrete mechanisms of absorption and radiation in the atom). However, there still remain uncertainties connected with the influence of the movement of electrons in atoms and with the influence of temperature on all three quantities measured in one (!) experiment.

It would seem that for electromagnetic interactions, there should be the least number of reasons to doubt in the relativistic equation of motion:  $\frac{d\mathbf{P}}{dt} = e\mathbf{E} + \frac{e}{c}[\mathbf{v} \times \mathbf{B}]$ , and, as a consequence, in relativistic conservation laws for the process of collision. Nevertheless, we shall make some further remarks on the issue of validity for relativistic description of the Compton effect. Above we have already considered some uncertainties for collision of balls – an analog of the “billiard”-type Compton model. We shall analyze the experiments described in the standard tutorials, for example, in [27,30,40]. Note that if the time of coincidence for instants of recording  $\gamma$ -quanta and electrons  $\Delta t > 10^{-20}$  sec, then the experiments not only do not prove the simultaneity of emitting of particles, but also do not allow to attribute unambiguously the particles to any one act of scattering. Such an accuracy is outside the limits of even modern possibilities (that is, this is still a matter of “faith”, and no statistics will help here).

It is methodically incorrect to call the electrons, participating in scattering, as free ones, because in such a case their number must be constant in the experiment. However, we have to consider this number different depending on the scattering angle, and with a

sufficiently small scattering angle, all the electrons “turn out” to be bound. In fact, however, all electrons participate in the momentum transfer (owing to their motion in an atom) and capture a part of energy from a  $\gamma$ -quantum (because they firstly were bound in the atomic system).

Some points in the Compton effect theory are not obvious. For example, what is the role of scattering on larger particles, than electrons, – on atomic nuclei (whether the interference and its influence from radiation, scattered on nuclei, are possible)? Why the non-shifted line is absent in the experiment with lithium (Compton, Wu)? On the contrary, it should always be present, for example, from scattering on a nucleus. Why exists there not alone displaced peak for all substances, but two peaks, located almost symmetrically relative to the initial line?

Besides, all tracks are not visualized (as in the ideal theory), but are only restored with the help of auxiliary means (and interpretations). That is, when trying to test the conservation laws, we are dealing with statistical hypotheses only. In the experiments, there are no estimates for the probability of double scattering from a specimen (but its value can be noticeable), and the role of repeatedly scattered “background” from all parts of the experimental setup is evaluated nowhere. The accuracy of experiments, even on determination of a scattering cross section, is low about 10% (and this is the statistical accuracy!). In so doing, the most presentable (favorable to the theory) events are chosen. For example, in the experiment by Crane, Gaerttner and Turin, only 300 cases from 10000 photos have been chosen (whether this is not too little?), and the coincidence of the data for the cross section of scattering with the Klein-Nishina-Tamm formula is declared. In the case of large thickness of specimens (Kohlrausch, Compton, Chao), the double scattering must obviously be taken into account. Similarly, it is obvious from the scheme of the experiment, that in Szepesi and Bay’s experiment the number of double scattering events is of the same order, as that of single scattering events. If this fact is not taken into account, the declared accuracy of 17% is rather doubtful. The declarative

corrections (fittings), made by Hofstadter in his experiment due to allegedly influence of various factors, cause bewilderment. In this case, after all corrections (fittings up to 30%!), the accuracy of 15% is declared.

In reality, in all above experiments, not the directions of particle dispersion are detected, but their hitting into the given place of space is fixed. Therefore, the experimental confirmation of a SRT interpretation occurs to be rather doubtful. For example, in the experiment by Cross and Ramsey, almost a half of points lie outside the theoretical curve, taking into account the stated tolerance limits. Of interest is the fact, that after removing a recording device from the plane of scattering, the number of coincidences in scattering acts remains to be considerable: it more than three times exceeds the background value. It is also rather strange to compare Skobeltsyn's experiments with the theory with using the ratio of a number of particles scattered to various angles  $N_{0^\circ}^{10^\circ} / N_{10^\circ}^{20^\circ}$ . You see, each of these quantities (both numerator and denominator separately) represents some averaged (effective) quantity. However, how is it possible, in the general form, to compare the ratio of average quantities (two experiments) with the ratio of true quantities (a theory) without using the theory of fluctuations?

For more complete theoretical substantiation of the Compton effect, not one collimator is required (for incident particles), but three collimators for separating, in addition, each type of scattered particles over narrow directions. For eliminating the background, the absorbers are also necessary. Then there will remain "only" the problem of filtering all particles over energies. Thus, even such an, apparently, purely relativistic phenomenon, as the Compton effect, is not experimentally verified to a complete measure.

### **Additional remarks**

The above described possibility of nonplanar motion even for two real bodies must be taken into account in the problem of the displacement of Mercury's perihelion (nobody made this).

Let us make some auxiliary remark. In deriving the relativistic expression for the momentum, “it is proved” that the momentum should be directed along the velocity, otherwise it would be indefinite. However, this reasoning is not rigorous in any way for a single particle, because in a system, where  $\mathbf{v} = 0$ , the direction of momentum is also uncertain. The classical expression for momentum follows from the Euclidean nature (homogeneity, isotropy) of space and from the invariance of mass. Following the minimum necessity principle, one can keep the classical expression both for the direction, and for the magnitude of particle’s momentum. Then all relativistic changes will be revealed in changing the expression for energy. Simply, it is necessary to remember that for charged particles, the field can also possess nonzero energy and momentum. And only the collision of neutral particles without internal degrees of freedom can be strictly elastic.

One more auxiliary remark. In the book [33] (exercise 65 – “the momentum without mass”), a platform on wheels is considered. At one of its ends, the motor with accumulator is installed, which rotates, by means of a belt-driven transmission (through the whole platform), the wheel with vanes in water at the other end of the platform. As a result, the electrical energy of the accumulator transfers from one end of the platform into the thermal energy of water at the other end of the platform. Again, we deal with a loss of determinacy (with non-objectivity): for “saving” SRT, various observers must draw different artificial conclusions about the paths and rates of energy (mass) transfer. For example, according to SRT, the observer on the platform should assign the energy (mass) transfer to the belt-driven transmission. And if we leave only two small pieces of the belt open to him for observation, then in what and how this mass transfer can be confirmed experimentally? The standpoint of classical physics is more legible: if one body acts on the second one, then the work performed is determined by the product of the acting force on the relative displacement:  $A = \int \mathbf{F}d\mathbf{r}$  or  $A = \int \mathbf{F}\mathbf{v}dt$ , where  $\mathbf{v}$  is the relative velocity. For example, under an effect of the friction force, a moving body stops. The kinetic energy



of a body relative to the surface will be numerically equal to the work of the friction force and is numerically equal to the amount of released heat. These quantities are invariant (do not depend on the observation system).

Now we shall make a methodical remark on confirmation of relativistic formulas. As a rule, the accuracy of experiments in the physics of the microcosm is usually low in a separate measurement act. However, this accuracy is artificially increased by choosing the events “needed for the theory” and by subsequent statistical processing the results (fitting under the theory). Unlike the classical field of investigation, nobody measures directly the value of velocity of particles in relativistic ranges of velocities, as well as the mass cannot be directly measured (only the value of  $e/m$  can be determined, but with using definite theoretical interpretations and for appropriate calibration of instruments). Therefore, it is impossible to substitute, in the explicit form, quantities  $v$  and  $m$  into calculated (!) values of energy and momentum and to verify the conservation laws of SRT. Even if one determines experimentally some nearly-keeping numerical quantities, the symbolic expression for energy and momentum can be extracted from these values by many various techniques, but with different results. And, you see, even the numerical values of energy and momentum have been measured indirectly (again, we are dealing with theoretical interpretations).

If some object possesses a speed which is larger than the speed with which you can move your hand, then you cannot accelerate this object with the hand (remember the carousel you spin yourself as a child); however, the speed of a collision during a contrary motion will be defined by the sum of the velocities. The situation will be quite analogous if we, using the electromagnetic field, will try to accelerate particles flying nearly the speed of transmission of electromagnetic interactions (the efficiency of acceleration will be small); but again the velocities of particles will be added for the head-on collision in an additive manner. Consider the following mental experiment. Let three observers at points  $A$ ,  $B$  and  $C$  be placed at one straight line. Let the distance  $|AB|$  be equal to the

distance  $|BC|$ . A periodical synchronizing source  $O$  is placed at the median perpendicular  $OB$ . The distance  $R = |OB|$  is very great. Note that all points are in the relative rest and this synchronizing procedure (from the remote source) is valid in the classical physics and in SRT as well. As the result of such the synchronization, a precision of the synchronization at the all three points  $A, B, C$  can be made an arbitrary value in advance by choosing the appropriate large value of  $R$ . Let there be radioactive sources at end points  $A$  and  $C$  radiating particles at speed  $0.9c$ . With receiving the first synchronizing signal from  $O$ , screens at points  $A$  and  $C$  are simultaneously opened. Particles from the points  $A$  and  $C$  fly to the central point  $B$  towards each other. The observer at the point  $B$  will see that the space between the two beams of particles are to be “eating up” with the speed of  $0.9c + 0.9c = 1.8c$ . With the same speed particles will “get one’s teeth into other’s body” (by choosing the length of the segment  $AC$ , the instant of collision can be adjusted just in time of the arrival of the second synchronizing signal to make sure that the calculation is correct). Just this speed is the speed of the particle’s collision, but the relativistic law of the velocity addition bears no relation to the reality at all. Apparently, the multiplicity of reaction channels in the physics of the microcosm is fictitious in many cases: simply the boundless faith of relativists in the relativity of quantities (and in the need for calculations using relativistic formulas) forces them to attribute various reactions occurring under completely different conditions to reactions that allegedly occurred with the same collision parameters (conditions).

There arises a question: can superluminal velocities (for usual particles, but not for fairy-tale “tachions”) be obtained and be observed by the real resting observer? We answer in such a manner: it is almost improbably that particle’s speeds would be principally limited to the light speed (in line with the above mentioned, more precisely – even to the double speed of light). This could be observed under several conditions only: first, true elementary particles must be absent in the Nature; second, all the World must possess the exclusively electromagnetic nature and must strictly obey to the

Maxwell equations. However, there is good reason to believe that 1) true elementary particles exist, that 2) in addition to electromagnetic interactions, there exist the other interactions (at least three additional types) in the Nature, and that 3) even the electromagnetic interactions themselves cannot be exclusively described by the modern form of the Maxwell equations (this fact was pointed out even by Ritz; remember also the fact itself of the birth of the quantum mechanics [139,140]). In practice, it can be proposed the following. Consider collisions of rarefied contrary beams of particles flying practically with the speed of light. At strictly head-on collisions of true elementary particles of the same charges but of rather different masses (protons and positrons, for example), the more light particles will possess speeds approximately equal to the double speed of light at scattering on  $180^\circ$ . Of course, the probability of such the events is small (but not zero!), since small deviations from the strictly head-on collision lead to essential deviation in final speeds of scattered particles from the above value. It is more difficult to realize a manifold repeated iteration of such the procedure (it is some analog of the Fermi acceleration) for obtaining more higher speeds, but it is possible in the Universe.

In studying collisions with particles being “at rest”, the question arises: where so many resting particles have been found from? And how had this fact been verified (since this circumstance can relate to determination of collision and scattering angles, of an aiming parameter, etc.)?

We concentrate our attention on the fact that the energy acquired in a unit time by a particle in its passage through an electromagnetic field region can be described by one and the same formula

$$\frac{dE_{kin}}{dt} = e\mathbf{E}\mathbf{v}.$$

both in the classical and in the relativistic cases [17]. This fact provide one of causes for the “near-successful” calculation of accelerators. Simply, one and the same “events” and readings of devices are ascribed to different scales of energy (more precisely, to differ-

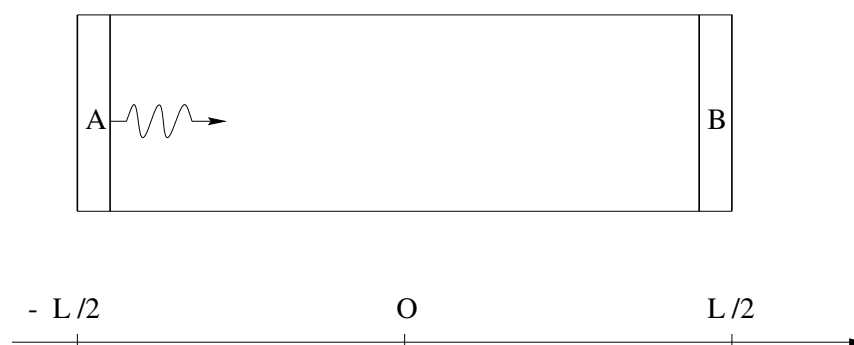

Figure 4.11: Interrelation of radiation mass with its energy.

ent combinations of letter symbols) in the classical and relativistic cases.

SRT bears no priority relation to explaining the presence of momentum in a photon. Any particle (including a photon) is detected from its interaction with other particles, that is, actually, from the momentum transfer. According to the modern concepts, the experimental basis for defining the presence of photon's momentum are Lebedev's experiments on measuring the pressure of light. The symbolic expression for a kinetic energy of photon can be elementarily deduced from the general definition:  $dE = \mathbf{v}d\mathbf{p}$  (from the general equations of motion). If we take into account that the photon moves at a speed of light  $v = c$ , then after integration we obtain  $E = cp$  without any SRT's ideas. However, this formula can be applicable to light in vacuum only (but not in other mediums).

Also, the semi-classical derivation of the Einstein formula [40] is fully unsatisfactory:  $\Delta E = \Delta mc^2$ . First, the notion of the center of masses is contradictory in SRT. Second, for some reason one remembers about acoustic waves in SRT only when they are unessential (distract from obvious paradoxes). But these waves bear some relation to the given situation. Let at the ends of a homogeneous tube with length  $L$  and mass  $M$  (Fig. 4.11) there are bodies  $A$  and  $B$

of negligible mass [40] (we take, for example, the monomolecular layers of the same substance). Let the atoms of layer  $A$  be at excited state. The following “circular process” is considered in [40]. At first, body  $A$  emits a short light pulse in the direction of body  $B$ . It is stated that the tube as a unified whole will begin to move. But this is not the case. Let the length  $L = 1$  cm. This emitted pulse will cause the body  $A$  to instantly bend and to move to the distance of about intermolecular one from the tube’s molecules, which hold it. Then the elastic force will arise, which tends to return the lost equilibrium. As a result, the complicated set of longitudinal and transversal oscillations will propagate along a tube. During the time, for which the light will reach body  $B$ , these acoustic waves will pass the distance not greater than  $10^{-5}$  cm (since  $v_{sound} \ll c$ ). A similar process will be repeated with body  $B$ . Thus, the oscillating tube will be stretched from the center  $O$  in opposite directions (towards the side of the body  $A$  – for a slightly greater distance), until the acoustic waves cancel each other out and equilibrium is established. But even this complicated real process does not matter, indeed. Further on [40], the body  $B$  with absorbed energy is brought into contact with the body  $A$  by internal forces; the body  $B$  returns energy back to the body  $A$  and returns to its place (and then the mathematical symbols are written). One moment! Third, in what manner could the body  $B$  transfer electromagnetic excitation energy without transferring momentum? Besides, it could be only the light pulse (otherwise, according to the second thermodynamic law, not all energy could transfer to the body  $A$ ). But in such a case, we would simply have a mutually reciprocal momentum transfer by means of light, and no global conclusions follow from this situation. The given problem is similar to the classical problem on throwing a ball in a boat from one person to another. The ball possesses a mass, and in flight it also has nonzero momentum and energy. The value of mass enters expressions for a momentum and kinetic energy, but no “all-Universe” conclusions follow from this situation. The thing sought in [40] can be obtained much easier. From the general expression  $dE = \mathbf{v}d\mathbf{P}$ , we have for light  $\Delta E = c\Delta P$ . If

we introduce, in a classical manner, the mass of motion  $P = mv$  for a photon, then the only possibility  $\Delta P = c\Delta m$  follows from  $v = c = \text{constant}$ . As a result, without any mental SRT ideas, we have  $\Delta E = c^2\Delta m$ . However, fourth, this result (irrespective of the method of its derivation) relates to the electromagnetic energy only and not to anything more (at least, there are no proofs of generality of the result).

Important note: the principle of least action does not work in the theory of relativity. Firstly, because the variables in the SRT are not independent, but are connected by a fictitious “interval”. Secondly, fixing the limits of integration in time and coordinates contradicts the very idea of relativism – the dependence of quantities on the relative velocity of the reference frame and the object. Further – from the viewpoint of mathematics, the following points follow. Thirdly, from the equality of the action integral to zero, it is possible to obtain many different subintegral expressions, the integral of which gives zero. Fourth, in the relativistic variation of the action, the integral is a scalar product of four-vectors, from the equality of which to zero does not have to follow the equality of zero for one of the components. Besides the fact that the solution turns out to be ambiguous (up to any terms orthogonal to  $\delta x^i$ ), these vectors themselves can be orthogonal. Fifth, in relativism, the Lagrange function must consist of invariants (true scalars), and the variation to (change of) any 4-vector is always orthogonal to this 4-vector (rotation). Thus, in SRT, the action has no extremes at all (regardless of variations – always identical zero). You can read more about this in [168].

An incorrect procedure may occur to be also the searching for equations in SRT to an accuracy of up to some expansion in  $v/c$ . The omitted terms can cardinaly change the form of a solution. The field of applicability of the approximate solution in time can occur to be such small, that the approximate solution will not have any theoretical and practical value (but how can this be detected without knowing the behavior of a true function?). It is also doubtful to derive an average solution from the approximate solution. A trivial

example: it would seem formally, that in the Lorentz force it is possible to neglect the magnetic force containing  $v/c$ . This is not the case, however: in the classical limit, instead of a real average drift of a particle at constant velocity perpendicular to both fields, we would obtain the accelerated motion along the field  $\mathbf{E}$ . In the relativistic limit [17], the velocity grows most rapidly also in the direction of  $[\mathbf{E} \times \mathbf{B}]$ . Apparently, due to this reason, the approximate Lagrange functions, constructed in SRT up to some term in  $v/c$ , can cause some problems, and the construction of an accurate Lagrange function is principally problematic in SRT. The limited nature of SRT results reveals itself in self-acceleration of charges under an effect of radiation reaction. The radiation is determined in the far-field zone and should not strongly depend on the processes occurring on particle scales: only re-evaluation of SRT rigorousness compels one to consider elementary particles as point-like ones.

In relativistic thermodynamics, Planck's solution and Ott's alternative are equally "strictly" derived. Physicists had been arguing for a long time about these temperature conversion choices. What to choose:  $T \rightarrow T_0/\gamma$  or  $T \rightarrow \gamma T_0$ ? They chose neither "polka dots", not "stripes" for the "dress of a bare king", but "striped polka dots". As a result, relativists negotiated to consider the temperature as an invariant. Thus, this proves once again that the theory of relativity is not a scientific theory, but only a collusion! Against science, of course.

Though the following methodical remark concerns kinematics first, it touches also upon the GRT and the relativistic dynamics as well. The problem is setted in [17]: to describe the motion of the system under investigation, which is uniformly accelerated relative to the own inertial system (the latter is instantly in the rest relative the system being investigated). A reader can have the natural question: whether the motion, which is uniformly accelerated relative to one inertial system, can really be nonuniformly accelerated relative to the other inertial systems or not? Unfortunately, the situation in SRT turned out to be exactly like this (we were lucky that the theory of relativity practically does not use the higher deriva-

tives, excluding the description of radiation, otherwise we could see many new “tricks”). However, what will we have with the equivalence principle: in one inertial system, there exists an equivalence to some one gravitational field (constant), but in the other inertial system, at the same space point, have we the changed gravitational (physical!) field? To “see” the flight of cobble-stones as balloons, with what a speed must the observer fly? But if we will attach the dynamometer to such the uniformly accelerated rocket and hang up a weight to the spring, then, whether differently moving (but with some constant velocities) observers would see that the dynamometer pointer show different Arabic cipher or not?

We mention the well known paradox of a relativistic submarine (the SRT was stopped in choosing as “the Buridan’s donkey” between two haystacks): from the viewpoint of an observer at the earth surface, the moving submarine must sink due to increasing its density as a result of submarine’s length shortening; contrary, from the viewpoint of an observer at the submarine, the latter must surface due to increasing of density of surrounding water. It was necessary to pronounce some kind of “magical pseudo-scientific spell”, and the relativists chose either to refer to the acceleration process, or to the curvature of space in the increased gravitational field, that is, they refer (sent back) to the GRT again. Apparently, this can be written as an epitaph: “the SRT tried to embrace the immensity, but never even possessed an own subject of investigation”. We re-formulate the present paradox in different manner to evidently see that gravitation bears no relation to this case. Let the following ANSWER be known from the viewpoints of both observers. At the usual earth conditions (i.e. at the weak gravitational field!), an usual submarine had successfully passed a path between two ships with a constant (non-relativistic!) speed at a given fixed depth (in transparent water). Now the question will be: what must declare different moving relativistic observers from the SRT viewpoint? Since the SRT “worked” with the exchange of light signals only, then, naturally, all SRT “declarations” must be seen by relativistic observers just with the help of the light by itself. When they will see “it”? Evidently,



it will be in just the time, when the light emitted in the moment of an “event” will reach them (as relativists claim, there not exist instantaneous relations). Let from the distance of 20 billions light years, two observers (in moving spaceships) will look in the direction of our submarine after 20 billions years (when, “possibly”, our submarine and ships will no longer exist), and let the observers will catch the signals from this remote event. Let the observers will be moving in parallel lines with a speed close to the speed of light, the one observer – in the direction of the submarine’s course, and the second one – in the opposite direction. It turns out that opinions of these two observers (the submarine was sunk or surfaced) must be different according to the SRT (as the different result of velocity additions). And after all, these observers must not believe even the spaceship that arrived after this event (with a slight delay, so as not to disturb the relativistic dream in vain) with the report that “the submarine had successfully executed the order at the GIVEN DEPTH”. We would like to believe relativists: it may be that hero Vasili Ivanovich Chapaev did not drown, in the case if some “right alien”, flying with a “right velocity” at some “right time”, will look at that remote event.

Of course, all losses of objective characteristics in SRT (which are presented here only for completeness of the picture) look simply as “student’s fittings” as compared to the logical gaps and contradictions existing in SRT. It is absolutely strange the advertising phrase spreaded by relativists as if the SRT is simply a new geometry and, therefore, it is allegedly noncontradictory (there are many geometries, but our World is one!). Possibly, they simply do not sense even the subject of physical investigations by itself (the physics studies causes of phenomena and concrete mechanisms directly influencing on the phenomenon under investigation). Of course, to mathematically obtain solutions, different transformations of coordinates are frequently used in physics (conformal ones, for example). In particular, the Lorentz transformations (but with the speed of sound) can be used for solving some problems in the acoustics (just since they are an invariant of equations). However, if somebody were claim

that the real change of the all Universe from the outer region into the inner one of a circle follows from correctness of some solutions, all physicists would understand “the adequate place” for such the claim. But if other but Very Big Relativistic Scientist claims that the all Universe was compressed when He walked to the nearest bakery, then many “yes-mans” will confirm this rubbish; it seems that these poor people were greatly deprived in childhood – they were not read the fairy tale “The Naked King” (The Emperor’s New Clothes) or they did not understand that this eternal fairy tale has the most direct relation to their lives.

From author’s standpoint, the most consistent attitude is a principal recognition of the results of relativistic dynamics and electrodynamics as approximate ones, to an accuracy provided by the experiment. One should not overestimate the possibilities of purely theoretical techniques and to overload the physics with globalisms. It is namely this reason and insufficient substantiation of relativistic experiments, why the author does not try to offer any alternative theory. At present, the theory should analyze and generalize those experiments, which have been carried out particularly in the region of high velocities.

Many critics of relativism raise the topic of plagiarism. Indeed, it is difficult to circumvent this ethical point. The thieves’ “logic” (apologetics) of relativists says: “A. Einstein’s accusation of stealing other people’s interesting ideas contradicts the statement about the fallacy of the theory of relativity.” Not at all: if someone stole a car and then crashed it, then the fact that there is no working car does not cancel the fact of its initial theft. So there was an unpleasant aftertaste from the fact that A. Einstein’s work lacked well-known references to his outstanding predecessors. To make up for such shortcomings, the author (and compiler) added the project “To remember All the Real First Ones” [206].

Of course, the difference in the **interpretations** of formulas by Einstein and by Lorentz is quite significant. For example, for the so-called “kinematic effect”, there is neither a cause nor a mechanism for its implementation (action): why is the whole Universe

shrunk, if only one person took it into his head to move (even if he is the “navel of the Earth”)? Therefore, such an effect has no place in physics (this is just a mathematical trick). In Lorentz, on the contrary, not every object was compressed relative to each with mutual motion (and certainly not the whole space), but only the one who specifically moved through the ether. Here there is also a reason (the beginning of movement at a specific speed through the ether) and a mechanism (interaction with the ether). Such an effect can already be discussed in physics. The difference between physics and mathematics consists in interpretation of formulas.

Why is Newton’s concept the most preferred? Classical concepts of physics have taken shape as a generalization of observations of conscientious researchers on the surrounding world within thousands of years (including astronomical observations of the Universe). Classical kinematic representations do not lead to internal logical contradictions or to contradictions with experiments. Does it make sense to discuss the so-called kinematic effects (for example, the mythical contraction or curvature of space)? Of course not: if we consider space itself to be curved, then the rulers would also be curved in the same way, and such a curvature could not be detected in any way. That is why classical concepts are chosen as ideal (and the simplest in practical use). Do classical concepts interfere with “filling” real matter by any properties? They not interfere at all! Any property of matter, that is discovered or can be discovered in the future, will be easily and organically incorporated into classical physics. For example, in classical physics, it is quite adequate to discuss the possible properties of ether (and in SRT there is no point in discussing ether, since in SRT it is devoid of observable properties). In classical physics, the issues of mass generation, charge generation, photon structure, etc. may well be discussed. Does classical physics interfere with the potential possibility of the existence of multilevel systems and movements (infinitely deep and wide and equally diverse)? It doesn’t interfere either. Newton’s first “law” speaks only about the ideal rectilinear motion of a selected body that does not interact with any other object. In the real Universe, such a situa-

tion does not strictly manifest itself (but only sometimes and approximately). Therefore, what type of natural motion (for example, circular motion or others) is realized in our only Universe, is entirely determined by the existing real interactions. Whether a more “economical” record will be found for describing motion than Newton’s second law, the future will show (such an “improvement”, generally speaking, is possible, but this is not a question on the correctness or infidelity of the very principle of description!). The equations of motion completely (!) determine the integrals of motion, and these do not have to be classical mechanical energy and momentum introduced for non-interacting structureless material points (let’s recall the classical examples with real dissipative processes, about hydrodynamic examples, etc.). And finally, in classical physics, there are not only relative quantities, but also absolute quantities (and this works fine in practice), so classical physics is already a more general theory than any theory that does not contain absolute quantities.

#### 4.4 Conclusions to Chapter 4

The given Chapter 4 was devoted to the criticism of relativistic dynamics. The logical inconsistencies in this, seemingly “working” and “verified” field of investigations, were presented.

In this Chapter 4 the criticism of the relativity notion was continued. Further on, the relativistic concept of mass was discussed in detail and its criticism was also given. The inconsistency of the concept of a center of masses in SRT was indicated. Then the Chapter 4 gave the criticism of the relativistic concept of force, of the transformation of forces and of the relativistic approach to various units of measurement. After this, the true sense (without SRT globalization) of the invariance of the Maxwell equations was considered. The criticism of the relativistic relationship between the mass and energy was also presented in Chapter 4. The so-called “experimental confirmations of the nuclear physics” were further criticized and some particular problems were considered in this respect. Such SRT aspects, as the radiation mass, the so-called Thomas’ precession and

other problems were critically discussed. The complete groundlessness of a generally-accepted interpretation of the relativistic dynamics was demonstrated, and the SRT interpretation of the Compton effect was analyzed in detail.

The resulting conclusion of the Chapter 4 consists in the necessity of returning to the classical interpretation of all dynamical concepts, in the possibility of the classical interpretation of relativistic dynamical solutions, and in necessity of closer examination of some phenomena in the field of great velocities.

## Appendix A

# Analysis of the “proof” for the existence of some invariant velocity

Let us consider in detail the article [158]. In this paper, an attempt is made to derive the relativistic law of addition of velocities, but only for parallel velocities, that is, nature is already limited by theory. To begin with, we will make preliminary remarks. What can  $c = \textit{constant}$  mean? The velocity of wave propagation does not depend on the velocity of the source in the classical physics as well. The constancy of the speed of light relative to the receiver (not inside the receiver!) has never been confirmed by anyone. Moreover, Rømer’s determination of the speed of light by the eclipses of Jupiter’s moon Io refutes such constancy. Obviously, the time of receiving the signal depends on the movement of the receiver (otherwise  $c \pm v$  would not appear in the formulas at all). And the expression  $c = \lambda\nu$  determines only the speed of the wave process **inside** a closed measuring device, but not the speed of propagation of the signal in the surrounding space. Time and clock are completely different concepts. Clock synchronization has nothing to do with the passage of time at all and is not necessary at all, since it does not change the duration  $\Delta t$ . And the primitive exchange of signals with each other resembles the

pigeon mail of the Middle Ages. Unlike the passage of time itself, the course of the clock and its desynchronization **depend** on the device of this very clock. Further in this Appendix, all references to numbered formulas refer to the work being criticized [158] (here it is desirable to have the work being criticized at hand to compare formulas). The author [158] set out to show that the most general relation (for parallel velocities!) compatible with the principle of relativity is the law of addition

$$w = \frac{v + u}{1 + Kuv}.$$

How can the most general thing be what is a special case: is it possible in reality to guarantee strict parallelism of speeds? Obviously not! For two velocities  $\mathbf{u}$  and  $\mathbf{v}$  with some given modules, the case of their parallelism is a set of measure zero. And for non-collinear vectors, the result of relativistic addition already depends on the order of its application (on the order of addition of velocities)!

The value of  $K^{-1/2}$  is not an “invariant velocity”, but a boundary velocity: the addition of two velocities less than this velocity gives a value also less than this velocity, but the addition of two quantities greater than this velocity also gives a value less than this velocity! Only if at least one of the quantities is exactly equal to this boundary velocity, the result of the “addition” will again be this velocity. As we can see, two additional, unsubstantiated postulates turned out about the impossibility of moving at speeds greater than  $K^{-1/2}$  and about the existence of a strange boundary velocity, from which it is impossible to “jump off” and on which it is impossible to “jump up”.

Mermin declares a method for reducing a function of two variables to a function of only one variable. But this is not always possible in mathematics, which means that some additional hypotheses and limitations will be artificially introduced, and even through thought experiments! The author [158] assumes in advance that the principle of relativity is fulfilled, that is, that we are dealing with isolated systems (identical systems without interaction, which is already a limitation of Nature), but at the same time, he is looking

for an open connection between relative velocities. In expression (2.3) from [158], he specifically introduced other variables so that the change in the meaning of the previous expression (2.2) was unnoticeable: pay attention to the indexes! In expression (2.2), the indices are clearly connected sequentially to each other:

$$f(v_{CB}, v_{BA}) \rightarrow v_{CA},$$

which corresponds to the physical meaning of adding speeds. If the author wanted to write an expression for  $v_{AC}$  through changing the sign, then it was necessary to write

$$- - v_{CA} = v_{AC} = f(v_{AB}, v_{BC}) = f(-v_{BA}, -v_{CB}).$$

Thus, instead of (2.3), the expression

$$f(-y, -x) = -f(x, y)$$

should be written, and no symmetry (2.6) with respect to the variables follows from any “general considerations”. Moreover, our point of view is confirmed by the fact that the general relativistic law of addition of velocities for non-collinear vectors depends on the order of velocities (noncommutative!). Therefore, the special case of parallel velocities does not have to be symmetric (commutative) at all.

Next. It is necessary to clearly subdivide **measurable** speeds (measured relative to the measuring device located in some concrete system) and **calculated** speeds (not related to the system in which the measuring device is located). Obviously, in our case, the velocity  $v_{AC}$  is the calculated velocity, since just for this purpose some function  $f$  is introduced, and the variables of this function are the velocities  $v_{AB}$  and  $v_{BC}$  – are the measured speeds. But then the measuring device can only be in the  $B$  system. Consequently, the addition of a new point  $D$  in article [158] only leads to the fact that new calculable velocities were simply introduced in expression (2.7), which the measuring device in the system  $B$  cannot measure:  $v_{DC}, v_{CA}, v_{DA}$ . At the same time, in the first of the expressions (2.8), the measurable



and calculatable velocities were reversed, which changes the physical meaning of the desired calculation function. The possibility of mixing the measured and calculated quantities in (2.9) is an additional physical hypothesis. We cannot assume in advance that when the measured and calculated quantities are replaced, the type of the desired function will remain the former (one and the same). For classical physics (linear dependence), the calculated velocity really does not depend on the motion of the observation system, but in relativistic physics for non-collinear vectors, this is no longer the case.

Note that in mathematics there is no such general property that a function of two variables is expressed as a function of one variable, even if it is “continuous and differentiable”. And plausible phrases about “parametric dependence”, “variable fixation”, as well as replacing the partial derivative in (2.10) with the full derivative (2.14), are intended to hide an obvious deception. Everyone can find elementary examples when it doesn’t work. Thus, (2.17) does not take place in the general case, that the Mermin’s “proof” supposedly claims. And since we saw earlier that symmetry (2.6) has no place in relativism, then equality (2.18) does not work any more. Then the expression (2.19) and the search for the function  $h$  lose their meaning. And  $h'$  could be equal to infinity if the derivative at zero turns out to be zero.

Next, instead of (3.1), we need to write other self-consistent expressions:

$$w = f(v, u), \quad s_1 = f(v, s), \quad s_2 = f(v, -s).$$

Expression (3.5) is correct, since it uses only some relativity from the classical physics. It is obvious that (3.6) no longer corresponds to the previous definitions. But even if we forget about everything said above, including the lack of meaning in the search for  $h$ , then the simplest solution (3.9) will be  $h'(s) = 1$ . Note, firstly, that in any case, we can only talk about determining the calculated speeds. And the measured speeds are determined from experience even without our math games (so the best choice is the simplest option). Secondly,

note that Mermin tries to justify a certain **unified** constant from the expression (3.9) for all cases of life. Note that the turtle and the hare will meet in any case: if one or even both are at standing, or moving at arbitrary speeds. By choosing  $u = 0$ , we get the simplest choice in the special case  $h' = 1$ . But the most important thing is that the integration of this fictitious function does not give any law of addition of velocities due to noncommutativity. If we assume the possibility of exotic (relativistic) transformations based on faith in the principle of relativity, that is, assuming the possible dependence of a number of quantities on relative velocity, then the assumption of the dependence of these quantities on the relative velocity **modulus** is an **additional hypothesis**. Then we cannot even be sure of the equality of the quantities measured when moving back and forth. For example, then one can doubt that in the train reference frame  $T_1(u) = T_2(u)$ . Further, again, it does not worth to confuse the measurable and calculatable quantities: instead of (4.1), it is necessary (for consistency with the function  $f$ ) to check  $t_1(v, u) - t_2(v, u)$ . The author's reasoning relates to the system of movement of the train only, that is

$$T_1(u) - T_2(u) = T'_1(u') - T'_2(u') \quad (4.3),$$

and instead of (4.6) we can write only

$$t_1(0, u) - t_2(0, u) = t_1(0, u') - t_2(0, u').$$

Then the author postulates (this is again an additional hypothesis) that this interrelation will be preserved in the  $v$ -system as well. We will not correct all the intermediate formulas of the analyzed article, but we will immediately write down the final expression

$$\frac{g(v)}{2v} = \frac{([f(-v, u) - f(v, u)] / (2v)) + 1}{[f(v, u) - v][f(-v, u) + v]}$$

and the limit:

$$k = \lim_{v \rightarrow 0} \frac{g(v)}{2v} = \frac{1 - \left. \frac{\partial f(v, u)}{\partial v} \right|_{v=0}}{u^2}.$$

But again, no special functions  $h'$  follow from here.

Further, the author notes that with a negative value of  $K$ , the law of addition of velocities (5.2) can lead to the result  $|v| + |u| \rightrightarrows -|w|$  if  $|v| > (-K)^{-1/2}$  and  $|u| > (-K)^{-1/2}$ . But for some reason, the author ignores another oddity with a positive value of  $K$ . The boundary velocity  $c = K^{-1/2}$  splits phenomena into three strange "Worlds":

- I)  $v_i < c$ ,
- II)  $c$ ,
- III)  $V_j > c$ .

At the same time

$$v_i + v_k \rightrightarrows v < c, \quad v_i + c \rightrightarrows c, \quad V_j + c \rightrightarrows c, \quad v_i + V_j \rightrightarrows V > c,$$

but when adding the velocities, each of which is greater than  $c$ , the particles "fall" into the I "World":  $2c + 2c \rightrightarrows$

$$\textit{displaystyle} \frac{4c}{5} \text{ (exactly the same result will be with } \frac{c}{2} + \frac{c}{2} \rightrightarrows \frac{4c}{5}\text{)}.$$

It is obvious that the speed of wave propagation does not depend on the speed of the source for any waves and at any corresponding speed of their propagation (which there are many). This is just a property of wave motion, including in classical physics. But there is no confirmation of the invariance of the speed of light in a vacuum yet. The velocity  $V = \lambda\nu$  determines the local velocity of a wave process inside the measuring device. And the determination of the magnitude of  $c$  by the eclipses of Io, the satellite of Jupiter, rather speaks about the dependence of the speed of light on the speed of the receiver. In any case, there is no other evidence yet.

Mermin proposes to determine the value of  $K$  from the expression (5.3), forgetting that in the system  $B$ , only two velocities are measurable:  $v_{CB}$  and  $v_{BA}$ . In essence, expression (5.3) is a **definition** of the quantity of velocity  $v_{CA}$  that is not measurable in the  $B$  system. But one expression cannot simultaneously determine two unknown quantities:  $v_{CA}$  and  $K$ . The article's author suggests "asking" about the value of  $v_{CA}$  in the  $A$  system. Relativity turns out to be strange! For some reason, we cannot believe the observer in the  $A$  system that he knows about the lengths and times in his system that

we do not measure (this knowledge from the point of view of exposing relativism is unprofitable for relativists). We supposedly have to calculate them ourselves according to artificial relativistic rules. But at the same time, we must blindly believe in the observer's readings in the  $A$  system about speeds. In general, “we read here, we don't read there”, ... and as the song sings, “and in otherwise, the beautiful Marquise, everything is fine, everything is fine” (they rescue SRT at any cost)! Generally speaking, the synchronization method, using an infinitely remote source at the midpoint perpendicular to the line of motion, unambiguously leads to classical quantities (spatial, temporal and motion characteristics).

We will also make brief remarks on the “justification” of the relativistic law of addition of velocities in [159]. The requirements, that the inverse transformation to a linear transformation and the product of transformations preserve the corresponding structure (make up a group), are additional requirements (and are not fulfilled for non-collinear movements). When Terletsky talks about the homogeneity of space, but at the same time tries to artificially introduce some strange transformations, it would be worthwhile to first answer the question: what to expect from parallel transfers for such fictional “physics” (how to avoid paradoxes)? In expression (7.6) from [159], the constant may depend on other coordinates:  $y_1, z_1$ . The very type of transformation (7.7) is a hypothesis: if we talk about generalization, then there may be cross-dependencies of coordinates.

Further, replacing only  $x \rightarrow -x, v \rightarrow -v$  changes the orientation of the triple of basis vectors. Therefore, in order for nothing to change in the transformation formulas (as the author of the “proof” wishes), it is necessary to swap  $y \leftrightarrow z$  ((this is immediately noticeable for a non-spherical object). The coincidence of the form for direct and inverse transformations remains in question. Big problems with “group properties” arise when moving to non-collinear vectors, so all these mathematical exercises look artificial.

Finally, the dependence of mass on velocity is far-fetched: it is not the mass that increases with velocity, but the effective force

decreases as the velocity of the body approaches the rate of transmission of interactions (the rate of transmission of momentum)! In the classical physics, there is also such a decrease in the effective force. Thus, the work [159] also cannot be considered rigorous in terms of substantiating relativistic invariance and the law of addition of velocities.

## Appendix B

# On possible frequency parametrization

In subsequent Appendixes, some particular hypotheses will be considered. Practically, they do not connected with the criticism of relativity theory from the main part of this book; they only demonstrate nonuniqueness of the SRT approach and a possibility of the frequency parametrization of all formulas. In the book, this is the only claim of these Appendixes, since we will use incorrect SRT methods (their error was proved in the main part of the book). The author attempted to discuss ideas from Appendixes B and C (plus a part of analysis of the Michelson experiment from Chapter 3) in several well-known journals in 1993-1999. The result turned out to be predictably the same: either the work was diplomatically not considering at once, or the approximate answer was like this: “No one has found anything like this in relativity theory and quantum electrodynamics, and the accuracy of the predictions of these theories was enormous.” How can theorist discover anything new (instead of explanation its “by late mind”)? He must assume some fact and test corollaries from his assumption. But nobody attempted to assume the possibility of frequency dependence of light speed. Besides, the case in point was the precision on one-two orders large than the existing modern precision of experiments. Such a precision can be

reached in the immediate future. Though in physics, experiments, that require accuracy several tens of orders of magnitude higher than modern ones, are seriously discussed. The author was tired to waste the time at last, and a decision was taken to test the “huge precision of relativity theory” (at the same time remembering a student dissatisfaction by this theory). As a result, my first own critical article appeared, and now this book. So everything has its pros and cons.

Now we proceed to discussion of a possible frequency dependence of light speed. It is well known that when particles are in vacuum, there occur various processes, such as the appearance of virtual pairs (a particle and its antiparticle); many interaction processes are described in terms of such virtual pairs. Light, during its propagation, also influences vacuum properties (in particular, vacuum polarization may take place). Therefore, by the reciprocity principle there must be a reverse action of vacuum polarization on the light propagation. As a consequence, the light (at a certain frequency) is bound to travel through the vacuum as “the medium” with some certain permittivity  $\varepsilon$ , which is determined by this light itself; that is,  $c = c(\omega)$ .

The generalization of the Maxwell equations by adding the mass term explicitly to the Maxwell Lagrangian is known to lead to the Proca equations in the Minkowski space (in the modern view). An electromagnetic wave propagating through the medium is influenced by the latter and this effect is manifested via the generation of massive photons [100]. Even with constant phase speed assumed, an  $\omega$ -dependence of the group speed (dispersion in vacuum) is known to arise:

$$v_g = (d\omega/dk) = c\sqrt{\omega^2 - \mu^2 c^2}/\omega,$$

where  $\mu$  is the rest mass of the photon. However, the question of mass generation and the gauge theories will not be discussed in these Appendixes. Our aim is just to represent some physical reflections about light velocity and attendant questions.

The questions arise here: 1) How can the  $\omega$ -dependence be evaluated or measured? 2) Why has it not yet been found, and 3) What corollaries follow?

There exist various methods for measuring light speed: astronomical methods, the method of interruptions, the rotating mirror method, the radio geodetic method, the method of standing waves (the resonator), the independent measurements of  $\lambda$  and  $\nu$ , and so on. At the present time, the last method [59,67] is the most precise; it is used by the Bureau of Standards for measuring light speed to eight significant digits. However, the principal difficulties arise in this approach [7]. Besides, it must be emphasized that this method is principally limited: either it can be connected with local (inside a device) speed of light only, or it can bear no relationship to light speed at all in the case if light by itself does not represent a pure wave. Why other methods are inadequate (fail to detect  $c(\omega)$  dependence) is clear from the previous Chapters and will be clear from given Appendixes for one particular hypothesis.

In further consideration we will follow the SRT methods (forget for a while that they are incorrect, but only give a “visibility effect” for two reference frames under an additional condition – under the condition of choosing the Einstein synchronization method). Recall that in deriving the corollaries of SRT (transformation laws, for example) the notion of the interval  $ds^2 = c^2 dt^2 - (d\mathbf{r})^2$  is used. Here it is necessary to make two methodological remarks. First, even the equality of intervals  $ds^2 = ds'^2$  is nothing more than one plausible hypotheses, since only a single point  $\Delta s = 0$  remains trustworthy (if we suppose  $c = \text{const}$ ). For example, we could pick any natural number  $n$  and equate the  $n^{\text{th}}$  degrees,  $c^n dt^n - dx^n - dy^n - dz^n$ , and obtain different “physical laws”. Or, we could consider  $t = t'$ , but  $c'^2 = c^2 - v^2$ , i.e.  $v' = v\sqrt{1 - v^2/c^2}$  (the apparent velocity of mutual motion is different for different observers). Such a choice results in coinciding of the relativistic longitudinal Doppler effect with the classical expression. Similar exotic systems could be as much intrinsically self-consistent as the SRT (i.e. for two marked objects only!), and only the experiments could demonstrate which choices are nothing more than theoretical fabrications. We shall not discuss all such exotic hypotheses here.

Second, in the usage of interval, the following point is not em-



phasized: the concrete light, propagating from one point to another, is used in each case, i.e. the value  $\mathbf{c}(\omega_i, \mathbf{l}_i)$  must be substituted in the expression for the interval. But in such a case, the proportionality of intervals from textbooks leads to an indeterminate interrelation:

$$\frac{a(\mathbf{l}_2, \omega_2, \mathbf{v}_2)}{a(\mathbf{l}_1, \omega_1, \mathbf{v}_1)} = a(\mathbf{l}_{12}, \omega_{12}, \mathbf{v}_{12}),$$

and even the equality of intervals cannot be proved. This indeterminate relation is associated with the still “unknown new Doppler law”, so there is again a need to turn to experience. Thus, theoretical constructions proceeding only from their own principles are not unambiguous. Since generally accepted SRT derivations results in some corollaries that are allegedly confirmed experimentally (for example, within some precision for particle dynamics?), we shall rely upon this method, but modify it with regard to the possible  $c(\omega)$  dependence.

Physically, this approach implies the following: The apparent result of some measurement depends on the measurement technique; and the calculated result depends, in particular, on the synchronization procedure for timepieces in different frames. According to an idea from this Appendix, no “unified interaction propagation speed”  $c$  exists (but  $c(\omega)$  only). If light of some definite frequency  $\omega$  is used for Einstein synchronization of timepieces in the different frames, then the apparent result of any experiment will depend on  $\omega$ . For example, if some process with characteristic frequency  $\omega_k$  takes place in a system, then it is natural to watch the system by using  $c(\omega_k)$  (just as the signal propagates). If two systems moving relative to each other are studied in the experiment, then two quantities  $c(\omega)$  and  $c(\omega')$  (for each system of reference) will appear in formulae. This is due to the fact, that the same light possesses different frequencies in systems moving relative to each other (this is detectable). As this takes place, the quantities  $\omega$  and  $\omega'$  are related to each other by the Doppler effect (see below). It is interesting to note the following circumstance. If several various processes with characteristic frequencies  $\omega_i$  take place in the system, then the observers moving

with respect to each other will see (at the same point) various pictures of events (the apparent effect). In the subsequent theoretical description we shall follow by analogy with [4,17].

Let  $\omega'$  be the frequency of signal propagation in some system. Substituting  $c(\omega')$  (instead of  $c$ ) into the four-dimensional interval  $ds'^2$  for the intrinsic system and  $c(\omega)$  into  $ds^2 = c^2 dt^2 - dx^2 - dy^2 - dz^2$  for the system of observation, it follows from  $ds^2 = ds'^2$  that the intrinsic time ( $d\mathbf{r}' = 0$ ) can be found from

$$dt' = dt \sqrt{\frac{c(\omega)^2 - V^2}{c(\omega')^2}}, \quad (\text{B.1})$$

but the formula for the intrinsic length retains its validity. We note again, that it is “a visible effect” only. In an arbitrary mathematical expression, coefficients can be transferred (according to some rules) from the left-hand side in the right-hand side of the expression and vice versa (all these expressions are equivalent). Then, how can it be determined: time accelerates at one observer or, contrary, decelerates at other one (and, accordingly, increased or decreased lengths)? Simply, if somebody were said to you that just yours time is slowed down relative to one object in one way, and relative to other objects by different manners, then you would immediately feel the delirium of an infinite number of such useless “informations”. However relativists say that yours time is OK, but simply “somebody has something somewhere far off”, and many people calm right away and continue to listen “the fairy-tales”.

To derive the Lorentz transformations, one can use rotation in the  $t, x$  plane:

$$\begin{aligned} x &= x' \cosh \psi + c(\omega') t' \sinh \psi, \\ c(\omega) t &= x' \sinh \psi + c(\omega') t' \cosh \psi. \end{aligned}$$

Using  $\tanh \psi = (V/c(\omega))$ , it follows that the Lorentz transformation reduces to

$$x = \frac{x' + \frac{c(\omega')}{c(\omega)} V t'}{\sqrt{1 - V^2/c(\omega)^2}}, \quad t = \frac{\frac{c(\omega')}{c(\omega)} t' + \frac{V}{c(\omega)^2} x'}{\sqrt{1 - V^2/c(\omega)^2}}, \quad (\text{B.2})$$

where  $V$  is the system velocity. Writing  $dx$  and  $dt$  in the expression (B.2) and finding  $d\mathbf{r}/dt$ , one obtains, that the transformations for velocity change into

$$v_x = \frac{\frac{c(\omega)}{c(\omega')}v'_x + V}{1 + \frac{v'_x V}{c(\omega)c(\omega')}}}, \quad v_y = \frac{v'_y \sqrt{1 - \frac{V^2}{c(\omega')^2}}}{1 + \frac{v'_x V}{c(\omega)c(\omega')}}},$$

$$v_z = \frac{v'_z \sqrt{1 - \frac{V^2}{c(\omega')^2}}}{1 + \frac{v'_x V}{c(\omega)c(\omega')}}}. \quad (\text{B.3})$$

It follows that for the motion along the  $x$  axis

$$v = \frac{\frac{c(\omega)}{c(\omega')}v' + V}{1 + \frac{v'V}{c(\omega)c(\omega')}}}. \quad (\text{B.4})$$

We see that the maximum of velocity is  $V_{max} = c(\omega)$ , where  $\omega$  is the light frequency in the intrinsic system. Note that all formulae lead to the correct composition law for motion along the same straight line (the transformation from frame  $A$  to  $B$  and from  $B$  to  $C$  yields the same result as the transformation from  $A$  to  $C$ ). Recall that, in accord with considerations given in the main part of the book, quantities  $t'$  and  $x'$  in formulas (B.1), (B.2) have no own physical meaning (they are fictitious auxiliary quantities). Formula (B.4), by analogy with formula (1.5), can be re-written as

$$v_{23} = \frac{v_{13} - \frac{c(\omega)}{c(\omega')}v_{12}}{1 - \frac{v_{13}v_{12}}{c(\omega)c(\omega')}}}. \quad (\text{B.5})$$

This form most clearly reveals the essence of this expression (the

apparent effect). The formula

$$\tan \theta = \frac{v' \sqrt{1 - V^2/c(\omega)^2} \sin \theta'}{\frac{c(\omega')}{c(\omega)} V + v' \cos \theta'} \quad (\text{B.6})$$

describes the change of the velocity direction. The relativistic expression for the light aberration holds (with the substitution  $v' = c(\omega')$  only). To be on the safe side, we are reminded that the relativistic expression for the stellar aberration is approximate. The transformations of 4-vectors are also maintained. From here follow the transformations of the wave four-vector  $k^i = (\frac{\omega}{c}, \mathbf{k})$ :

$$k_0^0 = \frac{k^0 - \frac{V}{c(\omega)} k^1}{\sqrt{1 - V^2/c(\omega)^2}}, \quad k_0^0 = \frac{\omega}{c(\omega)},$$

$$k^0 = \frac{\omega'}{c(\omega')}, \quad k^1 = \frac{\omega' \cos \alpha}{c(\omega')}.$$

As a result, the Doppler effect can be obtained from

$$\omega' = \omega \frac{c(\omega')}{c(\omega)} \frac{\sqrt{1 - V^2/c(\omega)^2}}{1 - \frac{V}{c(\omega)} \cos \alpha}. \quad (\text{B.7})$$

Note, that the dependence of light speed on the system motion follows from here (different frequencies  $\omega'$  correspond to different systems). However, as we shall see in the next Appendix, this effect is negligible for the visible region. Relativists declare that the expression of the Doppler effect contains the relative velocity. It is false. Let an explosion occur at some point on the Earth, and let some line of emission be radiated in short time. Let a receiver at the Pluton catch the signal. At which a moment must we determine this mythical relative velocity? The receiver can not see in the direction to this Earth point at the moment of explosion, and the source not exists at the moment of the signal receiving, and the Earth will be turned to the back side. Even in the absence of medium, we obtain,

instead of the relative velocity, the difference of absolute velocities at the moment of emission and at the moment of signal receiving (and it is not the same!). And what will happen in reality – experience must show.

The energy-momentum vector transforms as

$$P_x = \frac{P'_x + \frac{V\epsilon'}{c(\omega)c(\omega')}}{\sqrt{1 - V^2/c(\omega)^2}}, \quad \epsilon = \frac{\epsilon' \frac{c(\omega)}{c(\omega')} + VP'_x}{\sqrt{1 - V^2/c(\omega)^2}}. \quad (\text{B.8})$$

If we follow the idea of this application, there should be a closer analogy between the propagation of light in a medium and in a vacuum.

- 1) Various packets of waves diffuse in vacuum variously.
- 2) Light dispersion in vacuum imposes a fundamental limitation on the degree of ray parallelism.
- 3) There exists light dissipation in vacuum; that is, the intensity of light decreases as it propagates in vacuum.
- 4) Light “ages”, that is, the frequency of a light decreases when it propagates in a vacuum. This phenomenon can have a relation to the Olbers paradox (“why does the sky not flame?”) and can bring an own contribution to the red shift, that is, it is possible a correction for the concept of evolution of the Universe. Since we are factually dealing with an alternative explanation of the red shift, this effect appears to be very small, and, at present, it cannot be confirmed in laboratoty experiments: the red shift of lines for cosmic objects is already detected by the most precise optical methods and it becomes to be noticeable for very distant objects only, such the ones that distances to theirs cannot be found even with using the Earth’s orbit base (from the triangle). Recall in this connection that even an order of the value of Hubble constant had already been corrected.

Passing to quantum electrodynamics, the substitution  $c \rightarrow c(\omega)$  needs to be done in all derivations. For example, this dependence appears in the uncertainty relation

$$\Delta P \Delta t \sim \hbar/c(\omega), \quad \Delta x \sim \hbar/mc(\omega),$$

in the condition for the possibility of the classical description

$$|\vec{E}| \gg \frac{\sqrt{\hbar c(\omega)}}{(c(\omega)\Delta t)^2},$$

and in numerous formulae.

If some formula describes the  $\omega$ -dependence, then it can substantially change. As an example, we consider the emission and absorption of photons. As a result, the new coefficient

$$B = \frac{1}{1 - \frac{d \ln c(\omega)}{d \ln \omega}}$$

appears in the expression for the number  $N_{\mathbf{k}l}$  of photons with a given polarization:

$$N_{\mathbf{k}l} = \frac{8\pi^3 c(\omega)^2}{\hbar \omega^3} I_{\mathbf{k}l} B,$$

and in the relation for probabilities (of absorption, of induced and spontaneous emission)  $dw_{\mathbf{k}l}^{ab} = dw_{\mathbf{k}l}^{ind} = dw_{\mathbf{k}l}^{sp} B$ . Quantity  $B$  appears in the expressions for Einstein's coefficients also.

Using the substitution  $c \rightarrow c(\omega_k)$ , for natural field oscillations, one obtains the expression for the Fourier component of the photon propagator:

$$D_{xx} = \frac{2\pi i}{\omega_k} c(\omega_k)^2 \exp(-i\omega_k|\tau|).$$

We cannot find  $D(k^2)$  without knowledge of the explicit dependence  $c(\omega)$ . The explicit form of the  $\omega$ -dependence is necessary to find a net result for various cross-sections (for scattering, for the origin of a pair, for disintegration, etc.). As a first approximation, the substitution  $c \rightarrow c(\omega)$  can be made in the well-known formulae.

Now we shall discuss the possible  $c(\omega)$ -dependence.

## Appendix C

# Possible mechanism of the frequency dependence

We shall try to evaluate the  $c(\omega)$  dependence from semiclassical considerations (by analogy with optics). In fact, this is the possible hypothesis about the mechanism of propagation of electromagnetic oscillations (light) in vacuum. We describe vacuum as some system consisting of virtual pairs “a particle and its antiparticle” (really not existing). In the absence of real particles, the virtual pairs do not manifest themselves (do not exist really) in vacuum. The oscillations of virtual particles arise in the region of light propagation. The light propagation can be described as a successive process of interaction with virtual pairs (oscillatory excitations). The most important influence (wherein oscillations can easily be excited) is exerted by the lightest virtual pairs (electron/positron). So, only these pairs will be taken into account here.

Since the oscillations in an atom or in a positronium are the examples of real particle oscillations, they cannot define the natural frequency of virtual pairs. There exists some unique frequency, which can be related to a virtual (not existing without excitation) pair. The natural frequency of the pair can be defined as the frequency of the electron - positron pair origin, i.e.  $\omega_0 = 2m_e c^2 / \hbar$ , where  $m_e$  is the electron mass. From the viewpoint of such a de-

scription, it is reasonable to assume that the electron and positron are located at the same point for a virtual pair (the pair does not really exist - the full annihilation takes place). Using the classical model of oscillators, we can write the following expression for the phase velocity of light:

$$c(\omega) = \frac{c_0}{\sqrt{\varepsilon}}, \quad \sqrt{\varepsilon} = n - i\chi, \quad (\text{C.1})$$

$$n^2 - \chi^2 = 1 + 4\pi \frac{Nfe^2/m_e}{(\omega_0^2 - \omega^2)^2 + 4\omega^2\gamma^2} (\omega_0^2 - \omega^2),$$

$$n\chi = 4\pi \frac{Nfe^2/m_e}{(\omega_0^2 - \omega^2)^2 + 4\omega^2\gamma^2} \omega\gamma.$$

It remains to determine the quantities  $c_0$ ,  $\gamma$  and  $Nf$ . No doubt arises in choosing  $\gamma$ : this quantity is determined by the braking due to radiation (the only possible choice in vacuum). Thus,

$$\gamma = \frac{e^2\omega^2}{3m_e c^3}.$$

For the rest, we may study only those areas where classical electrodynamics is intrinsically non-contradictory and, besides, the quantum effects are insignificant, i.e.  $\omega \ll \omega_0/137$  and  $\lambda \gg 3.7 \times 10^{-11} \text{ cm} \gg R_0$ , where  $R_0 = e^2/(m_e c^2)$  is the classical electron radius. Quantity  $Nf$  denotes the number of virtual pairs in a unit of volume, which is sufficient for providing the light propagation process. In fact, this implies the determination of the size of a quantum of light and the quantity of virtual particles acting in it. Obviously, the longitudinal size of a quantum is  $l \sim \lambda$ . To provide the continuity of variation of fields  $\mathbf{E}$  and  $\mathbf{H}$ , it is necessary to suppose that the “substance” of a virtual pair be “spread out” along the whole quantum (see Fig. C.1) and rotates at frequency  $\omega$  around the local axis (perpendicular to the plane of this picture and intersect the axis  $C$ ).

The region occupied by one pair has the size:  $(2R_0, 2R_0, R_l)$ , where  $R_l = \lambda/I$ ,  $I$  is the number of “smudged” pairs. Since the



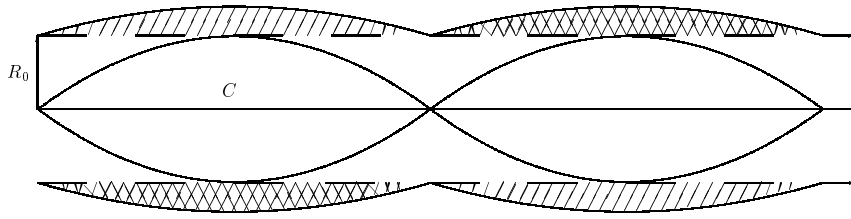

Figure C.1: Light propagation as successive polarization of vacuum.

mean kinetic energy (the magnetic field energy) is equal to the mean potential energy (the electric field energy), the number  $I$  can be found from the equality  $2Ie^2/(2R_0) = \hbar\omega$ . Then

$$R_l = \frac{2\pi ce^2}{\hbar\omega^2 R_0}, \quad Nf = \frac{\hbar\omega^2}{8\pi ce^2 R_0}.$$

The final approximate expression for the dimensionless phase velocity of light has the form:

$$\frac{c(\omega)}{c_0} = 1 - \frac{\hbar c_0 \omega^2}{4e^2} \frac{(\omega_0^2 - \omega^2)}{(\omega_0^2 - \omega^2)^2 + 4\omega^2 \gamma^2}. \quad (\text{C.2})$$

It is seen from this expression, that  $c_0 = c(0)$ . The phase velocity of light decreases as the frequency grows.

Now we make some estimations (see (C.2)). For the ultraviolet region:  $(\Delta c/c_0) \sim -0.5 \times 10^{-6}$  (in the visible region the effect is negligible). For  $\omega \sim 10^{18} \text{ s}^{-1}$  the effect is  $(\Delta c/c_0) \sim -1.4 \times 10^{-5}$ . Even for the ultraviolet region, the influence of Earth motion via the Doppler effect causes an effect of  $(\Delta c/c_0) \sim -10^{-10}$  (negligible); at the boundary of the region of applicability of this description ( $\omega \sim \omega_0/137$ ), we have:  $(\Delta c/c_0) \sim -3.6 \times 10^{-7}$ . Using the expression  $c^2 k^2 = \omega^2 \varepsilon$ , we have for the group velocity  $U_g = (d\omega/dk)$ :

$$U_g \frac{d(\omega\sqrt{\varepsilon})}{d\omega} = c_0.$$

The group velocity also decreases with frequency, practically coinciding in magnitude with the phase velocity. The greatest difference

between them is reached at the boundary of the region of applicability for this description (for  $\omega \sim \omega_0/137$ ), and equals 0.01 per cent (and in relation to  $c_0$  - of the order of  $2 \times 10^{-7}$ ). Note, that the above-used small sizes of a light quantum are quite justified (in the modern view). Such a compact object must interact with any object of the microcosm as a whole and practically instantaneously; but, actually, just these properties are postulated in quantum mechanics (in explanation of the photo-effect, or the Compton effect, for example).

The universally recognized modern experimental possibilities are inadequate for determining the  $\omega$ -dependence of light speed  $c$  in the visible region (and its dependence on Earth motion). Nevertheless, we are presenting here general considerations concerning the experiments. To detect the  $\omega$ -dependent  $c(\omega)$ , a purposeful search is necessary. The measurements must be direct, since any recalculation invokes some theoretical concepts related to the phenomenon under consideration. In particular, the experiments must be carried out in vacuum, because purely theoretical calculations of the interaction between the light and some medium cannot be made fully. In the general case, the interaction with a matter depends on the light frequency  $\omega$ . Particularly, the mirror must reflect waves of different  $\omega$  in a different manner (besides, reflection is not an instantaneous process). The recalculation, related with light transformations, does not take into consideration a possible  $\omega$ -dependence of light speed. In the general case, interruptions of light change the wave packet and, thus, its speed. Since free charged particles influence the effect, it is necessary to avoid the metallic shielding.

The method of interruptions requires simultaneous launch of the rays with different frequencies and adequate accuracy of comparison between time intervals over which the wave fronts travel a certain distance. Alternatively, one can eliminate the spectrum line from a mixture of two spectrum lines (lasers) by interruptions. Since reflections are not instantaneous processes and depend on the light frequency, the standard practice of distance lengthening by mirrors must be ruled out, or the number of reflections for each light beam

(for each different frequency  $\omega$ !) must be the same. The latter remark can also be applied to the interferometric method. We separate a ray (with  $\omega_1$ ) into two rays. The first ray is transformed into  $\omega_2$  at the beginning of path  $L$ , and the second ray – at the end of  $L$ . The path  $L$  can be changed. If there exists the dependence  $c(\omega)$ , then the interferogram will change with  $L$ . However, there are some technical problems in changing  $L$  without disturbances.

The astronomical research (for the rather wide spectrum  $\omega_i$ ) can help in verifying the  $c(\omega)$  dependence. One can observe (from a satellite) the (non-synchronous) appearance and disappearance of spectrum characteristic form in binary systems during the total eclipse. However, for great distances, there is no confidence that the light travels through real vacuum (without gases, plasmas, dust etc.). The mathematical analysis of  $c(\omega_i)$  for  $\omega_i$  is necessary to detect the  $\omega$ -dependent  $c(\omega)$ .

Of utmost interest is the comparison of  $c(\omega)$  for the visible region with that for X-rays or  $\gamma$ -rays. As far as we know, no appropriate experimental data exist for this region. However, there are a row of difficulties for experiments with  $\gamma$ -rays (on problems for the most precise method of direct independent measurements of  $\lambda$  and  $\nu$  in the wave model of light, see [7,59,67]); and absolute assurance of the wave nature of light is missing.

The most general question of these Appendixes is as follows: whether or not the vacuum retains its properties regardless of the presence of particles (photons) inside it. If vacuum properties can change, then there must be an inverse action on the particles (light) propagation process (this is just the principle of reciprocity). The  $c(\omega)$  dependence is some manifestation of this principle.

Thus, in Appendixes, the appropriate formulas were derived for corollaries from the  $\omega$ -dependence which were concerned the relativity, quantum electrodynamics, optics, etc. Purposeful experimental investigations are necessary in order to detect the fact of  $c(\omega)$  dependence itself. The maximum effect must be observed for the high-frequency region. In spite of serious experimental difficulties, possible outlooks are principally important and interesting.

One possible mechanism leading to  $c(\omega)$  dependence was discussed in this Appendix, but recall that no critical experiments exist to disprove the classical law of velocity addition even for the corpuscular model of light, to say nothing about the wave model of light. The problem is that for light, the following three relationships are uniquely interrelated (in the wave model of light):  $c(\omega)$  dependence, the Doppler effect and the velocity addition law. If and only if we know any two of these relationships with certainty, then the third relationship can be determined uniquely. For the wave model of light, the process of the electromagnetic oscillation (light) propagation through vacuum can be described as a successive origination of oscillation of virtual particles (in pairs) induced by the propagating light itself. (However, for the model considered in this Appendix, the question arises about the differences in the properties of light that arise during the annihilation of heavier particles, and the role of other virtual pairs, or about the “elementary” of elementary particles.)

## Appendix D

# Remarks on some hypotheses

Some relativistically minded authors, feeling the insufficiency or inconsistency of SRT and GRT, made attempts to generalize these theories. In their opinion, if relativity is chosen, it must be so in everything, although the relativity of accelerations contradicts experiments (the water in a rotating tank on a ship will acquire the shape of a paraboloid; however, a rotating chamber with this water will not testify that the surface of the water in the tank is flat, or that the surrounding ocean has acquired the shape of a paraboloid). If relativists-“pseudo-developers” introduce analogies with material properties, then this too is a claim to comprehensiveness. So, the author [175] adds a torsion property for the space. Fantasize, so fantasize! Traditional propagandists of relativism attacked this author not at all because it was impossible to fantasize like that. They felt threatened for their established scientific dogma and their well-being. After all, there appear doubts and additional questions to the theories of relativity. If the curvature of space, according to the fantastic imagination of relativists, can cause objects to experience attraction, then it is possible to materialize space even more by adding for it such a property of solids as elasticity to torsion. True, the experiment shows that a body of any composition, density or

mass can be made to rotate at the speed we need at any point in space (and the angular velocity will remain constant), or change the rotation frequency as we please. How is it that the curvature of space allegedly affects the movement of bodies by force, but the torsion does not? There exists no connection of this property with material objects. It remains only to fantasize about the new non-existent properties of the materially non-existent GRT space. Geometrization is generally an obsession for pseudo-mathematicians. They do not feel the concept of force. They do not understand that in zero gravity a snail or a fly can crawl along an apple or a pear in any direction with equal ease, and no geometry of these objects can hinder them. Well, geometry itself cannot determine the concept of force! And when they draw the geometry of the attracting gravitational center, they use psychological deception: any person subconsciously thinks that everything falls into the hole on its own (this is the experience of a person with the attraction of the Earth).

The work [164] can be considered the pinnacle of relativism, its logical conclusion. It introduces the concept of an orientable point (four orthonormal vectors) and finds the relationship of orientation with the coordinates of an event in four-dimensional space. As a result of using such individualized additional parameters, it becomes possible to eliminate some time-related paradoxes. Frankly speaking, even traditional theories of relativity do not have their own subjects of study (one cannot consider something artificially assigned to themselves by relativists to be real!). Therefore, it is highly doubtful that such a more complex mathematized theory can have its own field of study. The theory looks too artificial (and dubious, since SRT and GRT are declared as limiting cases). Although the author himself claims that his theory has exotic applications, the explanations look “far-fetched” “parallel”, not causal, i.e. the connection between his mathematics and reality is not traceable. So, the authors of [175] and [164] “far-fetch” Tolchin’s inertioid. It is well known from courses in general and theoretical physics that, due to internal forces, a closed system can turn at any angle relative to the center of mass (so that in the final position the relative

position of the system parts remains the same). However, these authors claim that a closed system can itself cause translational motion of its center of mass. It is well known that all inertoids move only in the presence of static friction and a supporting surface or line (due to the anisotropy of the static friction force caused by the change in the weight of the moving parts during accelerated movements). If the authors were right, then the thrust (acceleration and speed) would increase significantly when their design is placed on a flat-bottomed boat in water, where there is no static friction. However, the authors do not even try to conduct such a simple experiment (and replace it with a pseudo-variety of experiments where static friction is present). Without a supporting surface and static friction (in space, or with a parabolic trajectory of an airplane simulating weightlessness), such an inertoid will not begin to move progressively. The electrodynamic consequences also seem “far-fetched”. Of course, modern electrodynamics has many unsolved problems [140] and difficult questions, including the issues of interaction between non-inertial devices and non-inertial electromagnetic media (objects), for example, rotating ones, which are not fully clarified. Why then did not the generalization of electrodynamics to arbitrary non-inertial motion work in [164]? Such questions for rotating objects can be studied within the framework of electrodynamics, rather than constructing yet another multidimensional, now orientable monster. Although it is possible that in this particular case of rotation the answer is close to the truth, since in classical electrodynamics the analogy between the action of a magnetic field and rotation is well known. It is strange to attribute the allegedly super-penetrating action of the new radiation the main role in the transmutation of nuclei, since then it would be necessary to explain the influence of the experimental temperature, the electrode material (Pd, Ni, Fe ...) and the texture of its surface (and many other individual and poorly repeatable factors) on this elusive factor. Besides academic tasks with macro objects, when we set all the conditions ourselves, even in classical physics we often do not know the exact initial and boundary conditions. And in the theory

[164] we would need to know a much larger number of data (for statistical physics, nuclear physics, elementary particle physics and many other areas), which makes the practical use of the proposed procedure impossible (all that remains is to play the game of “what looks like what” with the help of pseudo-mathematics and to believe sacredly in our interpretations).

Thus, in works [175] and [164] we are fed a game that is divorced from reality (imagined without any prerequisites – out of thin air) with unjustifiably complicated mathematics (even if formally possible), the consequences of which are “as small as a fig leaf”, and quantitatively verifiable results “cannot be found even with a lantern”. Since a relatively small number of people are engaged in generalizing relativism and these theories are not forced to be taught in schools and universities, a detailed analysis of them is not included in the plans of this book.

Further in this Appendix, we shall touch upon some well-known hypotheses, which do not directly connected with the main part of the book. We begin with discussion of gravitation. The same square dependence on distance for both gravitational and electromagnetic forces urges on an incorrect idea that there exists the single universal mechanism of action for these forces and gravitation could be explained by means of an electromagnetic field; however, it contradicts experiments (for example, it does not be found any shielding of gravitation). The gravitational force cannot be some force of Van der Waals’ type, otherwise some long-range force, which weakly decreases with the distance, must exist (to obtain the squared dependence in the denominator, as in the Newton law), but it is absent. It is also incorrect an attempt to symmetrize gravitation by means of introducing “mass charge” with different signs. Gravitation manifests itself only as the attracting force. In addition to the banal question “where hides antigravitation?”, there exists a trivial refutation of “charge” approach. Let us consider a large body, for example, the Earth. Let it possess, for example, “positive mass charge”, and attracted bodies be “charged” by “negative mass charge”. Consider the opposite process (Fig. D.1). We will to tear off big fragments



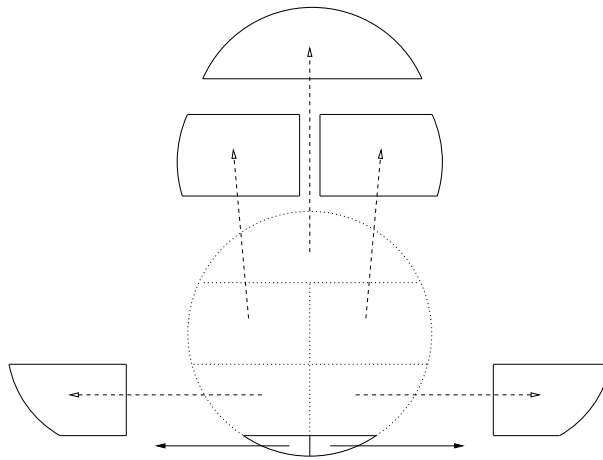

Figure D.1: Contradiction of “charged” gravitation.

from the Earth and take away far in space. It is well-known, that fragments which are heaved from the Earth, do not fly away by themselves in space, but fall back on the Earth. Therefore, positive “mass charge” must “flow down” on the remaining Earth after each such process. In this case, its quantity will increase (to conserve the total “charge”). The last remaining fragment *A* will attract bodies with a force that is large than one from the usual existing Earth. This is contradicts the proportionality of the gravitational force to the quantity of matter. Besides, there exists other contradiction: if the last fragment *A* had been tearing off strictly in half, then which of two halves would be positive and which be negative? Or, by tearing off in half, the parts will repelling each other and we will have antigravitation? (Although, the presence or absence of antigravitation could be not connected with the presence or absence of negative mass.)

Most likely, an attempt at a formal mathematical description of gravity as a quadratic effect of electrodynamics will be contradictory. The fact is that experiment shows the additivity of each of

the effects, i.e. the dependencies must be simultaneously (!) linear in both charges and masses of each body. Even at the level of microparticles and molecules, it is impossible to link mass and charge with an unambiguous dependence, and macroscopic bodies can generally be charged in different ways with different amounts of charges, and can be divided into arbitrary parts by mass (falling equally in a vacuum tube according to Galileo's mental experiments, which is confirmed experimentally). As a result, it is possible to obtain a completely arbitrary ratio between Coulomb and gravitational forces acting simultaneously. In addition, such hypotheses do not reveal the mechanism of the interaction itself in any way (which, it would seem, is what physics should do).

The incorrect attempt of geometrization of gravitation provokes attempts of geometrization of other fields, for example, electromagnetic one. Error of this idea is obvious: besides charged particles, there exist neutral ones which do not "feel" charges till they collide "head-on" with some particle. Therefore, in the same point of space, one particle would demonstrate a curved space, whereas other particle would prove absence of the curvature. Generally speaking, all above considered methods of formal reduction of one unknown force to some other unknown force have shown little promise.

It can be more useful to generalize the Newton static theory of gravitation with using of Maxwell approach (see [157] and [11], for example). Besides, there exists one more well-known interesting model. Unfortunately, mechanistic models are being permanently incited us as "something low-grade". But this is incorrectly. Similar models are the sole ones which can be created; we can "touch" them "by hands" and test their capacity for work. They can be understood by anybody (from a schoolboy to a famous scientist), and anyone can discuss them (contrary to models which are "completely proved among several scientist of a particular school of thought"). The concrete model under consideration consists in the following. It is assumed that in the Universe, very small neutral particles ("Lesagens"; the author – LeSage) constantly fly in all directions uniformly and interchange momentums with bodies in elastic colli-

sions. Two bodies cast shadows (or penumbra) to each other, and, as a result, they attract each other with the force that varies in inverse proportion to the square of the distance. But there exists one “but”. Since protons and electrons are opaque for these hypothetical particles, so it will be observed the departure of the mass dependence of attractive force from the proportionality to the product of masses for bodies with large sizes (with radii of the order of thousands kilometers and more). Unfortunately, this cannot be confirmed or disproved in experiments for the present. There existed yet another objection: a temperature of the Lesage’ gas must be very great, and the Universe must “burn”, since a thermodynamical equilibrium must quickly be established. However, subsequent modifications of this theory came already into being: 1) new Lesagens can permanently be absorbed by bodies (the latters are permanently “growing” herewith); 2) Lesagens can be transformed into such particles, which can desert the body.

Gravitation is not completely investigated even from the experimental viewpoint. For example, no precision experiments exist for measuring the influence of the mutual motion and rotation of bodies on the attractive gravitational force acting between them. There exist hypotheses of gravitational influence on the inert mass (and, therefore, on inertial forces, which arise in a rotating whipping top, for example). There arises a question (as some manifestation of relativistic cliches inculcated for us): relative what must the rotation be determined? There exists a practical method principally to verify an inertial system. Since we can define only the **variation** of a state (an extension of a spring between two rotating balls, for example) relative some other previous state, then it can be affirmed that this extension (due to an action of the centrifugal force) will be minimal for some frequency of rotation (naturally, considering the possible change in the direction of rotation). If this state of minimal extension is saved independently on orientation of rotation axis, then we have some inertial system. The question, whether it will be the heliocentric system or other one, cannot be solved from pure theoretical considerations for our sole Universe (abstract the-

orizing about the removal of almost all bodies from the Universe is not feasible in practice). It is obvious that the inertial forces will not change in form (mathematically), and only the dependence of the inert mass itself on gravity can be discussed. Probably, any detectable dependence of the inert mass on the direction of the resulting gravitational vector is impossible (alternatively, rotating liquids in the state of weightlessness could not be observed as ellipsoid of rotation, for example). Any noticeable dependence on the absolute value of the resulting gravitational vector is also improbable: in the opposite case, calculations of motion of comets, asteroids and meteorites were differ from accepted data by orders of magnitude (for example, due to the law of conservation of linear momentum, the velocity of a body which were moving away from massive bodies, such as the Earth, the Sun etc., would be increased, but it is not the case). At first, to discuss a dependence of the inert mass on the value of the total gravitational potential (in order to its variations in motion at great distances were small), it is necessary to define, from the all-physical and general-philosophical viewpoints, what meaning of the zero level of this potential, and what the method of its determination in our sole Universe (to make some quantitative evaluations). It seems reasonable to say that this dependence of the inert mass cannot also be appreciable (see the discussion on the Mach principle in the book). But, in the general case, the problem can principally be solved by experiments only. A row of cosmological problems could be theoretically solved, if it was assumed a boundedness of the radius of gravitational interactions [143]. But it is impossible yet to check this hypothesis, since the effect becomes remarkable for the great astronomical distances only. So, the theory of gravitation remained nearly in the same state as it was left by Newton. This field of knowledge waits for serious investigators.

The state of affairs in this area is described quite clearly and with a sense of humor in the article “Fake jewelry and decorated crutches of universal gravity”[207]. Here the author noticed a strange thing: why such an “accurate and key” experiment, conducted many centuries ago almost on wooden equipment, is not repeated, not that

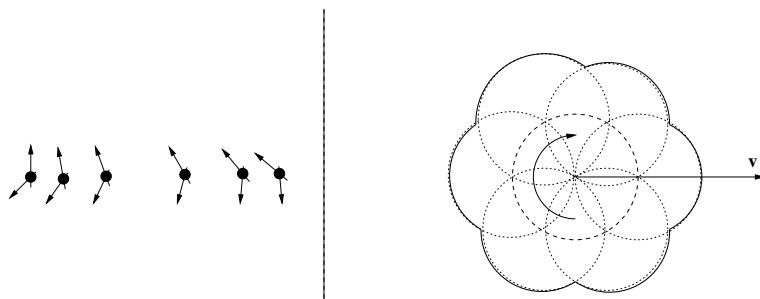

Figure D.2: Models of light.

in every school or university, but even in the world's largest universities or research centers? In general, if you read this work from the point of view of criticism, then you will not regret it (and you will think about it for sure!).

Despite the tacit prohibition to engage in the nature of light, the efforts made in this direction yield interesting fruits [147]. Now we will mention additional hypotheses that try to answer on the following question: “what is the matter of light by itself?” The postulate of corpuscular-wave dualism should not paralyze the human thought. It is impossible to manage without corpuscular properties of light. And since it is rather simple to imitate the wave properties with the help of particles (recall the real phenomena: sound in the air, sea waves, etc.), so at present, it is also urgent Newton's opinion that “light is rather corpuscles than waves”. But light can represent a pure wave, or it can be an intermediate something with a complex inner structure. This allows to construct different models of light (Fig. D.2). Light can be described even by a longitudinal wave (despite the experiment on polarization) in the case of oriented properties of light particles. Or it can be represented as some likeness of a “rotating gear”. In this case, the electromagnetic wave influence on a medium or instrument can be associated with angular frequency of revolution of the “gear”, and it can lead even to the relationship  $\lambda\nu = c = \text{constant}$ . However, such a local

(inside the instrument) speed of light  $c$  can be absolutely not connected with the velocity of motion of the “gear” as a whole (with the velocity of passage of the given distance by light in space). Assuming the presence of the photon’s own rotation and the classical law of addition of velocities in [60], the Doppler effect was obtained, which coincides with the relativistic one within the limits of modern measurement accuracy (up to the second order in  $v/c$ ). Some investigators have doubts even on the conventional Lebedev experiments (on the existence of the light pressure): firstly, some comets fly with tail forward to the Sun; secondly, evaluations show a too small effect, but a considerably greater value for the radiometrical effect. Unfortunately, the questions about the nature of light are also not solved both from theoretical and practical points of view. They also wait investigators.

A more large field relates the foundations of electrodynamics [140], but practically, we do not touch it in the present book. Although achievements in the field of electrodynamics for practical applications are really huge, nevertheless harmony in the conventional theory has not been feeling [20]. Many pieces of the theory are seemed as artificially joined to each other. At least there exist many unsolved methodical problems here. If we proceed from the correctness of the differential form of Maxwell’s equations, then instead of the Lorentz force, another “closing equation” [149] with its own interesting solutions is strictly obtained. Also we mention briefly the interesting idea of the new axiomatic approach to electrodynamics [12], attempts to revive Hertz’s electrodynamics and to generalize Weber’s force [89]. Recall that original Weber’s force was abandoned for the following reason: at some initial conditions, it resulted in the self-acceleration of charges. The similar self-acceleration of charges under the action of the braking due to radiation was “discovered” in SRT also, but, for some strange reasons, SRT did not be rejected (a “double standard” is observed). At present, the problem of self-acceleration (and other problem – the problem of the angular dependence of acceleration) has been rather successfully solving within the framework of Weber’s force. You can read more about

the problems of electrodynamics in [140].

It is impossible to bypass at least a brief mention of the ethereal theme. To date, the ether concept has a well-developed mathematical technique for solving many fundamental issues [142]. It is obvious that all ethereal theories are short-range theories and, generally speaking, are precisely physical theories that try to penetrate deep into things and understand the causes and mechanisms of phenomena (in contrast to the pseudo-mathematical nature of many modern theories). Ethereal theories have the most enemies (both among “highly educated semi-mathematicians - semi-physicists” and among specialists who thoughtlessly believe in near-scientific advertising), demanding the impossible from these theories: to immediately explain all the phenomena existing in the world (turning a blind eye to the fact that modern theories have not only not explained all the phenomena, but also have many problems and internal contradictions [139,140]).

N.A. Koltovoi reviewed numerous theories of the ether in his book 5 “New Physics”, Part 11. The theories of the ether are very diverse, even it would be difficult to list all the authors, so let’s just give some characteristic examples. For example, this is both a gas ether (V.A. Atsyukovsky; P.D. Prussov), and an electron-positron or photonic ether (A.V. Rykov), and a granular ether (A.I. Zakazchikov), and a domain ether (K.A. Haidarov), and a variously charged ether (F.F. Gorbatshevich), and ether having a charge of one sign (V.I. Mirkin), and solid ether (E.V. Gusev), and liquid ether (V.M. Antonov), and ether being a dense compressible inviscid medium (N.A. Magnitsky), and many others. The particles of the ether itself can also be isotropic, and anisotropic, and of several varieties, and have a number of complex properties, and transform, etc. Some theories are quite well developed. Which directions can be seriously analyzed? It is obvious that only a set of experimentally confirmed new predictions could confirm or refute one or another microscopic theory, or force them to abandon all (it is clear that the experiments advertised by universally recognized science cannot be considered critical). In the meantime, we can make the following

observations on the “internal” problems of some theories. If ether particles are able to transform, then what is the mechanism of self-healing and maintenance of experimentally verifiable identity and discreteness of many objects of our world? For ether particles with complex properties, problems arise again to explain these properties (their causes and mechanisms of occurrence and action). For example, if we consider ether particles with charges of both signs, then the previous unresolved questions remain: what forces hold each charge of one sign as a whole, what is the mechanism of attraction of charges with the opposite signs (that is, the questions are again transferred to a deeper level)? Why are these charges not neutralized? and others. If the ether consists of repelling particles of the same sign, then why is our world not purely gaseous (but it is also condensed into solid and liquid objects)? For the solid ether, the main “internal” questions are — what holds this solid formation together, and to explain the mechanism of movement through it without braking for objects of completely different sizes and energies from galaxies to elementary particles (yes, photons can pass through a crystal, and electrons move in a metal, but this happens in a solid body only for some objects and in a limited range of energies). The hypotheses of this Appendix are mentioned only in order to arouse the reader’s interest in independent meditation.



# Afterword

*I have no doubt that if the truth that three corners  
of a triangle are equal to two corners of a square  
contradicted someone's right to power or the interests  
of those who already have power, then the geometry:  
if yet would not be disputed, then would be necessarily supplanted  
by the burning of all books on geometry.  
(Thomas Hobbes)*

The given book was constructed as a critical review of the professional apologetics of the relativity theory. It was rather hard to write a consistent criticism of the theory, that had been repeatedly “hammered into our heads” from different points of view during our studies (starting from school): no matter what the consideration begins with, the finished stock phrases immediately come to mind (“beforehand prepared impromptus”). Besides, it is impossible to find the logic of presentation which would be simultaneously habitual for anybody (nonuniqueness of variants) or to locate the discussion of all nuances at one and the same place of the book. By this reason, the author hoped for reader’s patience and benevolence. The reader, which read to this afterword, will most likely agree that majority of the arising impromptu “notes in the margins of the book” was further explained. Trying to administratively stop even the slightest doubts in the relativity theory, one of academicians compares it with the multiplication table. Apparently, if somebody wrote a frank rubbish, but placed some examples from the multiplication table between paragraphs, then this academician would

recognize “the theory” to be true with “good conscience” and would call doubting mens to check “mathematical calculations”. However, physics presents itself not “mathematical flourishes” (independently on their truth), but the matter “round these flourishes” and its relation with the Reality. It was physics that this book touched upon. The result can be summarized as following. Many methodical and logical problems of the relativity theory was demonstrated in the book. The presence of methodical “problems of explanation” leads to the “blowing the theory at an empty place”. But the presence of logical contradictions puts the final point in the development of any physical theory. In Chapter 1 of the book, the logical inconsistency of SRT kinematics was proved on the basis of mental experiments. Chapter 2 was dedicated to logical contradictions of GRT. The absolute experimental inconsistency of the relativity theory was shown in Chapter 3. Chapter 4 proved the contradictoriness of relativistic dynamical notions and analyzed a possibility of the classical interpretation of relativistic dynamics. The ultimate conclusion of the book consists in the necessity of returning to classical notions of space, time and all derivative values, to the classical interpretation of all dynamical concepts, in the possibility of the classical interpretation of relativistic dynamics, and in necessity of closer examination of some phenomena in the field of great velocities. If the author succeeded already “to remove the RT hallucination”, then the local purpose of the book has been achieved. Some additional criticism of RT and accompanying theories can be found in papers and books (their titles speak for themselves) from the bibliography at the end of the book.

If we look intently at the known human history, an impression arises that somebody “beted on one cent” on the following. Is it possible to deceive all the mankind (first of all, the “skilled specialists”)? And it turned out as possible case even for such a comparatively exact science as physics. After all, even A. Einstein was surprised that everything he comes into contact with turns, although not into gold, as in a fairy tale, but into a newspaper boom. And he doubted in the rightness of his creation all the time. A quite different matter

is the case of modern “scientists near the relativity theory”. They try to consolidate their status by administrative means for ever. We take, for example, the creation of “The Commission for Fight with Pseudo-Science”. It would seem that the rather noble goal is declared – to protect the state from being robbed by charlatans. However, analogous organizations are absent in majority of other countries and nothing happens to their purses. In our country, the practice of examination before financial decisions was also present always. From ideas viewpoint, the scientific association itself has abilities to separate incorrect ideas, and, especially has immunity to charlatanism. The situation becomes more clear, when the following opinion is declared as right and final: someone having doubt as to relativity theory is not physicist. Different opinions, theories, schools can exist on any other question. But suddenly “the hub of the Universe” is discovered – this is not subject to discussion! And how must we treat physicists before 1905: whether they are not physicists? And how must we treat physicists from 20th century (including some Nobel Prize winners), since they were opponents to the relativity theory? Are they all not physicists? How can science be generally progressing without free discussion of ideas and their gradual understanding? The statement is well known that no one, including the creator of RT, understood the relativity theory. But relativists declare with pride that understanding and clearness are primitive and are beneath their dignity (it is need simply to repeat some fixed procedure). Factually, the regular idol is created from the idea (and there exist inviolable priests near it).

Unfortunately, the situation with the relativity theory cannot be remedied with the help of separate publications. Even if most scientist will understand the error of the relativity theory, it will be rather difficult to ‘blow off this soap-bubble’. By the way, it would be interesting to conduct a survey among people with a physics education: do they consider the interpretations of the theory of relativity to be correct or erroneous? If the survey will be anonymous (since relatively recently, expulsions from the Academy of Sciences were constantly “organized” for statements against the SRT, and

the repressive capabilities of the “new pseudoscientific commission” can also be demonstrated), then the author is ready to predict its result. But even this can be yet insufficient. It is necessary to change the culture of scientific relations itself, so that a sufficient number of scientists can openly declare after Aristotle (“friend of Platon”): “TRUTH is more valuable”, than a thousand-dollar salary (this is a modern remake of history). The final point in the question of the falsity of the relativity theory can be put only when a decision is made on a corresponding change in the teaching program at schools and universities and a change in the examination program, including postgraduate and PhD.

The author felt some inner dissatisfaction with the relativity theory in the time as a student, since SRT brings contradictions with the attitude of the world primarily laid into man from God. However, then there was nothing to object to in essence and had to assimilate the lecture material that was included in the program. Probably, many scientists and engineers remember the similar dissatisfaction (the author knows the same opinion of several scientists). It leads often to a loss of the interest by scientists in the fundamental physical problems and to retreating scientists into a research field with clear basis, methods and results.

Of course, the Soviet (and now Russian) education system has always differed its better side in contrast with the Western education system in that it provided a single universal knowledge, and not knowledge of the “piecewise tetrix type”. However, both systems have a common disadvantage. In these systems, students tune in to assimilate a huge flow of information (“to be moving in limits of a rut”), and not for them to develop independent thinking (but after all, most of the existing theories have not answered all the questions in their fields). Finally, all lessons were learned (all plausible answers were memorized) and the relevant exams were passed in the required way. But now not everyone will have the strength and desire to return to the material they have passed, and, at least for themselves, to verify the theories studied.

It is strange that in textbooks it is impossible to find mentions

of disagreements and a great number of internal problems, which present in any section of physics (the *Feynman Lectures on Physics* are the pleasant exception to the rule). They do not be problems of type “to count up anything or to prove the existence of a solution” (these are mathematical rather than physical problems). The problems of physics are the following: what the matter “stands behind equations”, what is the physical sense of values and laws, how an appropriate model can be constructed, how experiments and theoretical solutions can be interpreted?

Even some famous scientists try to suppress the interest for physics. From time to time, there appear their statements on the “imminent end of science”. The situation looks in such a manner that they will determine a “strategy of the end”, but remaining scientists must faster fuss and “go without hesitation to count the 108th term in some third approximation”. The author believes that the independent thought is the most important matter of studies for anybody. By this reason, the author does not propose own alternative theories to the relativity theory in the book (only gives the brief mention of some known hypotheses without criticism – the “lash” must be adequate to pretensions of the theory).

And the last. I would like to dream. Can something change in the physical community for the better? At first, we indicate existing problems. Unfortunately, the past century led to considerable deterioration of the culture of scientific relations. Formerly scientists were unhurried and could thoroughly investigate separate phenomena, leaving unsolved problems to progeny (recall Newton’s phrase “I do not contrive hypotheses”). But the past century “amended”. There appeared some haughty relation to notions, methods and ideas from the past. They say, since we “dive” into such a depth of microcosm and fly in cosmic space, almost all phenomena are well-known. Although, in fact, most of the problems of type “underfoot and around” have remained at the same level as a century ago (and in other scientific fields, it is simply more difficult to distinguish the reality of results from declarative interpretations – there are fewer witnesses). An amount of publications became the basic criterion

for scientist (can ten dried-up peels replace the juicy orange?). The Nobel Prizes played a considerable part in this “hurry”, since their criterion included illusory “novelty” instead of the eternal TRUTH. In fairness, it should be emphasized that the healthy conservatism of the Nobel Committee at the beginning of the 20th century did not allow this prize to be awarded to either SRT or GRT. Nevertheless, near-scientific advertising slowly eroded moral foundations, and the policy of “divide and rule” gradually penetrated into the scientific community. From a community of people seeking the TRUTH, the scientific community has in many cases transformed into a competing clan structure for making money (where even the cited literature on one topic does not overlap).

What would we like to see as some ideal? I would like scientists to strive to make a complex phenomenon more understandable, and not hide behind pseudo-sciencelikeness (the “number of floors of formulas” should correspond to their significance). I would like that scientists came to seminars not to ask their own question and “kick” the speaker, but to understand what this or that speaker is offering and “not to splash the baby out with the water”. We would like that scientists were having the courage to admit own mistakes (both mistakes and their admission have no fatal at all) and were searching the truth in science rather than were fighting for the own name at science. I would like that authors do not seek quantity and do not “dilute” new work with previously published results. Among works of different levels, such as: “it is not necessary to publish this”, “it is possible not to publish this”, “it is possible to publish this”, “it is necessary to publish this” and “it is impossible not to publish this”, I would like that the authors to try to fight only for the last two types of works. I would like that the reviewers to be more responsible about their work (otherwise, in a huge stream of “sodden friendly information”, it is simply impossible to understand and, as in an anecdote, you have to choose whether to be a reader or to be a writer). I would like that scientific schools (and reviewers) to adopt from their leader the best, not the worst external manners (like “this is all wrong” ; if he did not divine, then “it’s all been

known for a long time”; if he again did guess wrong? well, then “no one is interested in this”, and since “no one” is one reviewer, then you can continue to “walk around the bazaar and look for a buyer” as much as you like). Possibly, it is worth to depart from a collective irresponsibility of the “friend’s group” and to publish who reviewed an article, who from editors recommended it, and (as an appendix at last journal pages) what manuscripts were rejected and by who (and extracts from the reviews). I would like that scientific journals present the really broad spectrum of opinions on scientific topics rather than the particular opinion of editor-in-chief (and controlled by him collective). I would like that the main criterion to any scientific article to be the absence of logical contradictions, mathematical errors and agreement with the experiment (as is customary, for example, in the journal *GALILEAN ELECTRODYNAMICS*). The presence of the other conventional (at the given time instant) theory must be no influencing the consideration of an article. I would like that all above mentioned dreams could be realized in real actions of people. If we would dream, then we must dream of the something “BIG”.

# Bibliography

In Russian

- [1] Atsyukovsky V.A. **General Etherodynamics**. (Energoatomizdat, Moscow, 1990).
- [2] Atsyukovsky V.A. **Critical Analysis of Basis of the Relativity Theory**. (Zhukovskii, 1996).
- [3] Bergmann P.G. **Introduction to the Theory of Relativity**. (Inostrannaya Literatura, Moscow, 1947).
- [4] Berestetskii V.B., Lifshitz E.M., Pitaevskii L.P. **Quantum Electrodynamics**. (Nauka, Moscow, 1989).
- [5] Bunin V.A. Eclipsing Variable Stars and the Problem on the Light Speed Dispersion in Vacuum // *Astronomical Journal*. 1962. No. 4. pp. 768-769.
- [6] Gardner M. **Time Travel and other Mathematical Bewilderments**. (Mir, Moscow, 1990). [In English: (W.H. Freeman and Company, New York, 1988).]
- [7] Danilchenko V.P., Solov'ev V.S., Machekhin J.P. **The current Status of Calculations and Measurements of the Speed of Light**. (Nauka, Moscow, 1982).



- [8] Zakazchikov A.I. **Returning of Ether**. (Sputnic+ Company, Moscow, 2001).
- [9] Ismailov V.P., Karagios O.V., Parkhanov A.G. The Investigation of variations of experimental data for the gravitational constant // *Physical Thought of Russia*. 1999. V. 1/2. pp. 20-26.
- [10] Kanarev F.M. **Are you Continuing to Believe? or Decided to Check?**. (Krasnodar, 1992).
- [11] Klyushin Ja.G. **Some Consequences from Maxwell Approach to Description of Gravitation**. (L'ubavitch, S-Peterburg, 1993).
- [12] Klyushin Ja.G. **The Basis of Modern Electrodynamics**. (S-Peterburg, 1999).
- [13] Komarov V.N. **Universe Visible and Invisible**. (Znanie, Moscow, 1979).
- [14] Kotel'nikov G.A. Group Properties of Wave Equation with Noninvariant Speed of Light // *Theor. Math. Phys.* 1980. V. 42. pp. 139-144.
- [15] Kotel'nikov G.A. The Galilean Group in Investigations of Symmetric Properties of the Maxwell Equations. In **Group Theoretical Methods in Physics 1**, 466-494 (Nauka, Moscow, 1983).
- [16] Kurnosova L.V. Scattering of Photons of Different Energy on Electrons // *Uspekhi Fizicheskikh Nauk*. 1954. V. 52. pp. 603-649.
- [17] Landau L.D., Lifshitz E.M. **The classical Theory of Fields**. (Nauka, Moscow, 1988).
- [18] Logunov A.A., Mestvirishvili M.A. **Relativistic Theory of Gravitation**. (Nauka, Moscow, 1989).

- [19] Mandelshtam L.I. **Lectures in Optics, Relativity Theory and Quantum Mechanics**. (Nauka, Moscow, 1972).
- [20] Nikolaev G.V. **Modern Electrodynamics and Causes of its Paradoxicality**. (Tverdynya, Tomsk, 2003).
- [21] Okun' L.B., Selivanov K.G., Telegdi V.L. Gravitation, Photons, Clocks // *Uspekhi Fizicheskikh Nauk*. 1998. V. 169. pp. 1141-1147.
- [22] Pobedonostsev L.A., Kramarovskiy Ya.M., Parshin P.F., Sellesnev B.K., Beresin A.B. Experimental Determination of the Doppler Shift of Hydrogen Lines on Beams of  $H_2^+$  Ions in the Energy Region 150-2000 KeV // *Journal of Technical Physics*. 1989. V. 59. No. 3. pp. 84-89.
- [23] **Problems of Space, Time, Motion**. Collected Articles of 4th International Conference. V. I. (St-Petersburg, 1997).
- [24] Poincare A. **On Science**. (Nauka, Moscow, 1983).
- [25] Rozenberg G. Speed of Light in Vacuum // *Uspekhi Fizicheskikh Nauk*. 1952. V. 48. pp. 599-608.
- [26] Savel'ev I.V. **Physics**. V. 1. (Nauka, Moscow, 1989).
- [27] Savel'ev I.V. **Physics**. V. 3. (Nauka, Moscow, 1987).
- [28] Savchuk V.D. **From Relativity Theory to Classical Mechanics**. (Feniks+, Dubna, 2001).
- [29] Sekerin V.I. **The Relativity Theory – the Mystification of the Century**. (Novosibirsk, 1991).
- [30] Sivukhin D.V. **Atomic and Nuclear Physics**. Part 1. (Nauka, Moscow, 1986).
- [31] Sivukhin D.V. **Optics**. (Nauka, Moscow, 1985).
- [32] Sivukhin D.V. **Electricity**. (Nauka, Moscow, 1977).

- [33] Taylor E.F., Wheeler J.A. **Spacetime Physics**. (Mir, Moscow, 1968). [In English: (W.H.Freeman and Company, San Francisco, 1966).]
- [34] Ugarov V.A. **Special Relativity Theory**. (Nauka, Moscow, 1969).
- [35] Feynman R.P., Leighton R.B., Sands M. **The Feynman Lectures on Physics**. Part 2. (Mir, Moscow, 1977). [In English: V.1, (Addison-Wesley, London, 1963).]
- [36] **Physical Encyclopaedia**. V. 2. (Sovetskaya Encyclopaedia, Moscow, 1962).
- [37] Fock V. **The Theory of Space, Time and Gravitation**. (Physmatgis, Moscow, 1989). [In English: (Pergamon Press, London, 1959).]
- [38] Frankfurt N.U., Frank A.M. **Optics of Moving Body**. (Nauka, Moscow, 1972).
- [39] Schmutzer E. **Relativitätstheorie - Aktuell**. (Mir, Moscow, 1981).
- [40] Shpolskii E.V. **Atomic Physics**. (Nauka, Moscow, 1974).
- [41] Einstein A. **Collected Scientific Works**. (Nauka, Moscow, 1967).
- [42] **Ether Wind** (ed. V.A. Arts'ukovskii). (Energoatomizdat, Moscow, 1993).

In English

- [43] Agathangelides A. The GLORY in Small Letters // *Galilean Electrodynamics*. 2002. V. 13. Spec.Iss. pp. 19-20.

- [44] Agathangelides A. The Sagnac Effect is Fundamental // *Galilean Electrodynamics*. 2002. V. 13. pp. 79-80.
- [45] Aleshinsky V. Electrodynamics: the Consistent Formulas of Interaction for a Current Elements, a Moving Charges and New Effects // *Spacetime and Substance*. 2002. V. 3. No. 1/11. pp. 1-14.
- [46] Antoni G., Bartocci U. A Simple Classical Interpretation of Fizeau's Experiment // *Apeiron*. 2001. V. 8. pp. 139-145.
- [47] Antonopoulos C. A Bang into Nowhere: Comments on the Universe Expansion Theory // *Apeiron*. 2003. V. 10. pp. 40-68.
- [48] Arteha S.N. On the Basis for Special Relativity Theory // *Galilean Electrodynamics*. Fall 2003. V. 14. Special Issues 2. pp. 23-28.
- [49] Arteha S.N. On Frequency-Dependent Light Speed // *Galilean Electrodynamics*. Spring 2004. V. 15. Special Issues 1. pp. 3-8.
- [50] Arteha S.N. On Notions of Relativistic Kinematics // *Galilean Electrodynamics*. Spring 2005. V. 16. Special Issues 1. pp. 9-13.
- [51] Arteha S.N. On the Basis for General Relativity Theory // *Spacetime and Substance*. 2002. V. 3. No. 5/15. pp. 225-233.
- [52] Arteha S.N. Some Remarks to Relativistic Kinematics // *Spacetime and Substance*. 2003. V. 4. No. 3/18. pp. 114-122.
- [53] Arteha S.N. On Notions of Relativistic Dynamics // *Spacetime and Substance*. 2003. V. 4. No. 4/19. pp. 174-181.
- [54] Arteha S.N. Some Remarks to Relativistic Experiments // *Spacetime and Substance*. 2003. V. 4. No. 4/19. pp. 188-192.
- [55] Arteha S.N. Critical Comments to Relativistic Dynamics // *Spacetime and Substance*. 2003. V. 4. No. 5/20. pp. 216-224.

- [56] Assis A.K.T., Neves M.C.D. History of the 2.7 K Temperature Prior to Penzias and Wilson // *Apeiron*. 1995. V. 2. pp. 79-87.
- [57] Beckmann P. Sagnac and Gravitation // *Galilean Electrodynamics*. 1992. V. 3. pp. 9-12.
- [58] Bertram S. The Lorentz Transform // *Galilean Electrodynamics*. 1995. V. 6. pp. 100.
- [59] Blaneu T.G., Bradley C.C., Edwards G.J., Jolliffe B.W., Knight D.J.E., Rowley W.R.C., Shotton K.C., Woods P.T. Measurement of the Speed of Light // *Proc. R. Soc. London A*. 1977. V. 355. pp. 61-114.
- [60] Boldyreva L.B., Sotina N.B. The Possibility of Developing a Theory of Light Without Special Relativity // *Galilean Electrodynamics*. 2002. V. 13. pp. 103-107.
- [61] Brillet A., Hall J.L. Improved Laser Test of the Isotropy of Space // *Phys. Rev. Lett.* 1979. V. 42. pp. 549-552.
- [62] Cahill R.T., Kitto K. Michelson-Morley Experiment Revisited and the Cosmic Background Radiation Preferred Frame // *Apeiron*. 2003. V. 10. pp. 104-117.
- [63] Campbell J.O. Black Holes – Fact or Fiction? // *Apeiron*. 1998. V. 5. pp. 151-156.
- [64] Claybourne J.P. Why an Ether is Positively Necessary and a Candidate for the Job // *Galilean Electrodynamics*. 1993. V. 4. pp. 38-39.
- [65] Claybourne J.P. The Reciprocity of Einstein's Special Relativity Theory // *Galilean Electrodynamics*. 1992. V. 3. pp. 68-71.
- [66] Drury D.M. Lorentz's Galilean-Invariant Form of Maxwell's Equations in Free Space // *Galilean Electrodynamics*. 1992. V. 3. pp. 50-56.

- [67] Evenson K.M., Wells J.S., Petersen F.R., Danielson B.L., Day G.W., Barger R.L., Hall J.L. Speed of Light from Direct Frequency and Wavelength Measurements of the Methane-Stabilized Laser // *Phys. Rev. Lett.* 1972. V. 29. pp. 1346-1349.
- [68] Flandern T.V. On the Speed of Gravity // *Galilean Electrodynamics*. 1993. V. 4. pp. 35-37.
- [69] Flandern T.V. What the Global Positioning System Tells Us about the Twin's Paradox // *Apeiron*. 2003. V. 10. pp. 69-86.
- [70] Flandern T.V. The Top 30 Problems with the Big Bang // *Apeiron*. 2002. V. 9. pp. 72-90.
- [71] Fominskiy L.P. To Concept of an Interval or Basic Mistake of the Theory of Relativity // *Spasetime and Substance*. 2002. V. 3. No. 2/12. pp. 49-54.
- [72] Galaev Yu.M. Etheral Wind in Experience of Millimetric Radiowaves Propagation // *Spasetime and Substance*. 2001. V. 2. No. 5/10. pp. 211-225.
- [73] Galaev Yu.M. The Measuring of Ether-Drift Velocity and Kinematic Ether Viscosity within Optical Waves Band // *Spasetime and Substance*. 2002. V. 3. No. 5/15. pp. 207-224.
- [74] Galezki G. Physical Laws and the Theory of Special Relativity // *Apeiron*. 1994. V. 1. pp. 26-31.
- [75] Galezki G., Marquardt P. A Non-expanding, Non-relativistic Universe // *Apeiron*. 1996. V. 3. pp. 108-113.
- [76] Guala-Valverde Jo. The Identity of Gravitational Mass/Inertial Mass. A Source of Misunderstandings // *Spasetime and Substance*. 2001. V. 2. No. 1/6. pp. 42-43.
- [77] Hatch R.R. Relativity and GPS-II // *Galilean Electrodynamics*. 1995. V. 6. pp. 73-78.

- [78] Hatch R.R. In Search of an Ether Drift // *Galilean Electrodynamics*. 2002. V. 13. pp. 3-8.
- [79] Hayden H.C. Is the Velocity of Light Isotropic in the Frame of the Rotating Earth // *Physics Essays*. 1991. V. 4. pp. 361-367.
- [80] Hayden H.C. Stellar Aberration // *Galilean Electrodynamics*. 1993. V. 4. pp. 89-92.
- [81] Hsü J.P., Hsü L. A Physical Theory Based Solely on the First Postulate of Relativity // *Phys. Let.A*. 1994. V. 196. pp. 1-6.
- [82] Huber P., Jaakkola T. The Static Universe of Walther Nernst // *Apeiron*. 1995. V. 2. pp. 53-57.
- [83] Jaseja T.S., Javan A., Murray J., Townes C.H. Test of Special Relativity or of the Isotropy of Space by Use of Infrared Masers // *Phys. Rev.* 1964. V. 133. pp. A1221-A1225.
- [84] Kanarev Ph.M. Photon Model // *Galilean Electrodynamics*. 2003. V. 14. Spec.Iss. pp. 3-7.
- [85] Kholmetskii A.L. Is the Theory of Relativity Self-consistent? // *Apeiron*. 2001. V. 8. pp. 74-83.
- [86] Kolen P., Torr D.G. An Experiment to Measure the One-Way Velocity of Propagation of Electromagnetic Radiation // *Found. Phys.* 1982. V. 12. pp. 401-411.
- [87] Laplace P.S. **Mechanique Celeste**. English transl. reprinted by Chelsea Publ. (New York, 1966).
- [88] Lindsay R.B. **Theoretical Physics**. (Dover Publications, New York, 1969).
- [89] Lucas Ch.W., Lucas J.C. Weber's Force Law for Finite-Size Elastic Particles // *Galilean Electrodynamics*. 2003. V. 14. pp. 3-10.
- [90] Marinov S. *Czech.J.Phys.* 1974. V. 24. pp. 965.

- [91] Marinov S. *Gen.Rel.Grav.* 1980. V. 12. pp. 57.
- [92] Marmet P. GPS and the Illusion of Constant Light Speed // *Galilean Electrodynamics*. 2003. V. 14. pp. 23-30.
- [93] Martin A. Light Signals in Galilean Relativity // *Apeiron*. 1994. V. 1. No. 18. pp. 20-25.
- [94] Michelson F.F., Pease F.G., Pearson F. Repetition of the Michelson-Morley Experiment // *J.Opt.Soc.Amer.* 1929. V. 18. pp. 181-182.
- [95] Miller D.C. The Ether-Drift Experiment and the Determination of the Absolute Motion of the Earth // *Revs. Mod. Phys.* 1933. V. 5. pp. 203-242.
- [96] Mocanu C.I. Is Thomas Rotation a Paradox? // *Apeiron*. 1993. V. 1. No. 16. pp. 1-7.
- [97] Montanus H. Special Relativity in an Absolute Euclidean Space-Time // *Physics Essays*. 1991. V. 4. pp. 350-356.
- [98] Munera H.A. Michelson-Morley Experiments Revisited: Systematic Errors, Consistency Among Different Experiments, and Compatibility with Absolute Space // *Apeiron*. 1998. V. 5. pp. 37-53.
- [99] Nascimento U. On the Trail of Fresnel's Search for an Ether Wind // *Apeiron*. 1998. V. 5. pp. 181-192.
- [100] Novak M.M. The Effect of a Non-Linear Medium on Electromagnetic Waves // *Fortsch. Phys.* 1989. V. 37. pp. 125-159.
- [101] Papazian H.A. On the Mass of the Photon // *Galilean Electrodynamics*. 1993. 4, 75-77 (1993).
- [102] Peshchevitskiy B.I. Relativity Theory: Alternative or Fiasco // *Galilean Electrodynamics*. 1992. V. 3. pp. 103-105.



- [103] Pogany P. Uber die Wiederholung des Haress-Sagnaschen Versuches // *Annalen der Physik*. 1926. V. 385. Iss. 11. pp. 217-231.
- [104] Prasad R. A Non-Riemannian Universe // *Apeiron*. 1996. V. 3. pp. 113-116.
- [105] Renshaw C.E. The Radiation Continuum Model of Light and the Galilean Invariance of Maxwell's Equations // *Galilean Electrodynamics*. 1996. V. 7. pp. 13-20.
- [106] Rindler W. *American Journal of Physics*. 1961. V. 29. pp. 365.
- [107] Robertson H. Postulate Versus Observation in the Special Theory of Relativity // *Rev.Mod.Phys*. 1949. V. 21. pp. 378-382.
- [108] Rodrigues W.A.Jr., Tiomno J. On Experiments to Detect Possible Failures of Relativity Theory // *Found. Phys*. 1985. V. 15. pp. 945-961.
- [109] Sannikov-Proskuryakov S.A., Cabbolet M.J.T.F. Towards the Ether Theory (Apology of the Ether) // *Spasetime and Substance*. 2001. V. 2. No. 4/9. pp. 171-174.
- [110] Sannikov-Proskuryakov S.A., Cabbolet M.J.T.F. Non-Einsteinian Theory of Gravity // *Spasetime and Substance*. 2003. V. 4. No. 1/16.
- [111] Shaozhi Xu, Xiangqun Xu. A Reexamination of the Lorentz Transformation // *Galilean Electrodynamics*. 1992. V. 3. N0. 1.
- [112] Shaozhi Xu, Xiangqun Xu. On the Relativity of Simultaneity // *Apeiron*. 1993. V. 1. No. 16. pp. 8-11.
- [113] Sherwin Ch.W. Measurement of the One-Way Speed of Light // *Galilean Electrodynamics*. 2002. V. 13. pp. 9-13.

- [114] Shtyrkov E.I. Time Evolution of Vacuum Parameters as the Bases for a Cosmological model // *Galilean Electrodynamics*. 1997. V. 8. pp. 57-60.
- [115] Silvertooth E.W. *Specul.Sc. and Technol.*. 1986. V. 10. pp. 3.
- [116] Sutliff D. Why Physics Cannot Assume the Relativity of Motion or an Infinite Universe: Problems with Special and General Relativity // *Physics Essays*. 1991. V. 4. pp. 217-222.
- [117] Theodorsen T. Relativity and Classical Physics // *Galilean Electrodynamics*. 1995. V. 6. pp. 63-72.
- [118] Tolchelnikova-Murri S.A. The Doppler Observations of Venus Contradict the SRT // *Galilean Electrodynamics*. 1993. V. 4. pp. 3-6.
- [119] Torr D.G., Kolen P. Misconceptions in Recent Papers on Special Relativity and Absolute Space Theories // *Found. Phys.* 1982. V. 12. pp. 265-284.
- [120] Turner K.C., Hill H.A. *Bull.Amer.Phys.Soc.* 1963. V. 8. pp. 28.
- [121] Volchenko A.P. About the new Approach to Construction of the Special Relativity // *Spasetime and Substance*. 2000. V. 1. No. 3/3. pp. 130-134.
- [122] Wang Zh.Y. Failure of the Relativistic Energy-Momentum Relation for Photons in Media // *Galilean Electrodynamics*. 2003. V. 14. pp. 56.
- [123] Whitney C.K. Finding Absolution for Special Relativity Theory // *Galilean Electrodynamics*. 1996. V. 7. pp. 23-29.
- [124] Whitney C.K. The Twins, the Mesons, and the Paradox // *Apeiron*. 1997. V. 4. pp. 104-109.
- [125] Whittaker E.T. **A History of the Theories of Aether & Electricity**. (Longman, Green and Co., London, 1910).

- [126] Wilhelm H.E. Galilei Covariant Electrodynamics of Moving Media with Applications to the Experiments of Fizeau and Hoek // *Apeiron*. 1993. V. 1. No. 15. pp. 1-5.
- [127] Wolff W.F. A Modified Newtonian Treatment of Gravity // *Galilean Electrodynamics*. 2002. V. 13. pp. 55-58.
- [128] Yi Y.-G. On the Nature of Relativistic Phenomena // *Apeiron*. 1999. V. 6. pp. 205-216.
- [129] Zhuck N.A. The Cosmic Microwave Background as Aggregate Radiation of all Stars // *Spacetime and Substance*. 2000. V. 1. No. 1/1. pp. 29-34.
- [130] Zhuck N.A. New Concepts about the Universe and its Laws // *Spacetime and Substance*. 2000. V. 1. No. 3/3. pp. 98-104.
- [131] Zhuck N.A. Modern Concepts of Space, Time and Boundedness of Lorentz Transformation Laws // *Spacetime and Substance*. 2003. V. 4. No. 1/16. pp. 1-6.

Additional References to the 3rd Edition:

In Russian:

- [132] Akimov O.E. **Natural Philosophi: lectures**, (UNITY-DANA, Moscow, 2001). [in Russian].
- [133] Arteha S.N. **Criticism of the Foundations of the Relativity Theory**, (Editorial URSS, Moscow, 2004), (Izdatelstvo LKI, Moscow 2007). [in Russian].
- [134] Arteha S.N. On the paradoxes of relativistic kinematics. *Proceedings of the Congress-2004 "Fundamental Problems of Natural Philosophi and Technics"*, Series "Problems of the Study of the Universe", Issue 28, Saint-Petersburg, 2004, pp. 24-37.

- [135] Arteha S.N. Criticism of the relativistic dynamics. *Proceedings of the Congress-2004 "Fundamental Problems of Natural Philosophy and Technics"*, Series "Problems of the Study of the Universe", Issue 28, Saint-Petersburg, 2004, pp. 38-51.
- [136] Arteha S.N. On some paradoxes of the relativity theory. *Proceedings of the VIIIth International Scientific Conference "Space, Time, Gravitation"*, 16-20 August 2004, Saint-Petersburg: TESSA, 2005, pp. 7-18.
- [137] Arteha S.N. Criticism of some aspects of the relativity theory. *Proceedings of the IXth International Scientific Conference "Space, Time, Gravitation"*, Saint-Petersburg: TESSA, 2007, pp. 7-17.
- [138] Arteha S.N. On the relation of classical and relativistic mechanics. **International Conference "VIIth Okunev Readings"**. 20-24 June 2011, Saint-Petersburg. Proceedings. Baltic State Technical University, 2011. pp. 29-30.
- [139] Artekha S.N. **Foundations of Physics (Critical View): Quantum Mechanics**, (Moscow: LENAND, 2015, 208 p.). [in Russian].
- [140] Artekha S.N. **Foundations of Physics (Critical View): Electrodynamics**, (Moscow: LENAND, 2015, 208 p.). [in Russian].
- [141] Brillouin L. **Relativity Re-Examined**, (Academic Press, 1970).
- [142] Bychkov V.L., Zaitsev F.S. **Mathematical Modelling of Electromagnetic and Gravitational Phenomena Using the Methodology of Mechanics of Continuum Media**, (Moscow: Maks Press, 2016.).
- [143] Zhuck N.A. **Cosmology**. (Model Vselennoy Ltd, Kharkov, 2000). [In russian].

- [144] Klyushin E.B. **The Lectures on Physics Delivered to Myself**, (Publishing House “Bumazhnaya Galereya”, Moscow, 2005). [In russian].
- [145] Lebedev T.A. **About Some Controversal Issues of Modern Physics**, (Leningrad Polytechnical Institute, 1955).
- [146] Manuilov K.V. Critical analysis of Einstein’s work “Explanation of motion of Mercury’s perihelion in the general relativity”, *Proceedings of the VIIIth International Scientific Conference “Space, Time, Gravitation”*, 16-20 August 2004, Saint-Petersburg: TESSA, 2005, pp. 403-429.
- [147] Moiseev B.M. **Physical Model of a Light Quantum**, (Moscow: Book House “LIBROKOM”, 2011, 80 p.).
- [148] Petrov Ju.I. **Paradoxes of Fundamental Physical Concepts**, (Moscow: URSS, 2012, 336 p.).
- [149] Smulsky I.I. **The Theory of the Interaction**, (Publishing House of the Novosibirsk University, NIC OIGGM SD RAS, Novosibirsk, 1999). [In russian].
- [150] Fedorov R.V. **Physics: Crisis Problems, New Beginnings**, (Chernovtsy: PRUT, 2005, 400 p.).
- [151] Fedorov R.V. **Dialogue about the Physics of Motion**, (Chernovtsy: PRUT, 2008).

In English:

- [152] Arteha S.N. Critical Remarks to the Relativity Theory // *Spacetime and Substance*. 2005. V. 6. No. 1/26. pp. 14-20.
- [153] Arteha S.N. On classical physics without relativity. Abstracts, **13th Annual Conference of the Natural Philosophy**

**Alliance (NPA)**, 3-7 April 2006, University of Tulsa; see also: Natural Philosophy Alliance, Newsletter, V. 12, No. 2, July 2006, p.4.

- [154] Artekha S., Chubykalo A., Espinoza A. Some of the complexities in the special relativity: new paradoxes // *Physical Science International Journal*. 2016. V. 11(1). pp. 1-15. DOI: 10.9734/PSIJ/2016/26788.
- [155] Artekha S.N., Chubykalo A., Espinoza A. On the Question of the Invariance of the Light Speed // *Journal of Modern Physics*. 2017. V. 8. pp. 1213-1233. doi: 10.4236/jmp.2017.88080.
- [156] Beckmann P. **Einstein Plus Two**, (Golem Press, 1987).
- [157] Jefimenko O.D. **Causality, Electromagnetic Induction and Gravitation. A Different Approach to the Theory of Electromagnetic and Gravitational Fields**, (2nd Edition, Electret Scientific Company, Star City, 2000).
- [158] Mermin N.D. *Amer. J. Phys.* 1984. V. 52. No. 2. p. 119.
- [159] Terletskii Ya. **Paradoxes in the Theory of Relativity**, (Springer, NY, 1968).

Additional References to the 4th Edition:

In Russian:

- [160] S.N. Artekha, **Foundations of Physics (Critical Viewpoint): Criticism of Foundations of the Relativity Theory**, (Moscow: URSS, 2018, 288 p.).

- [161] J. Bernal, **Science in the History of Society**, (Moscow: Inostrannaya Literatura, 1956).
- [162] L.I. Verkhovskiy, **Memoir on the theory of relativity and unified field theory**, (Moscow, 2000). [In Russian]
- [163] V.P. Vizgin, **Historical and Mathematical Research**, vol. XIX, (Moscow: Nauka, 1974). [In Russian]
- [164] E.A. Gubarev, **Principle of the Real Relativity**, (Moscow: Fond Perspektivnykh tekhnologii i novacii, 2020, 336 p.).
- [165] O.D. Jefimenko, **Prichinnost', Elektromagnotnaya Indukcia i Gravitaciya. Drugoi podkhod k teorii elektromagnitnykh i gravitacionnykh polei**, (Moscow: URSS, 2021, 226 p.).
- [166] V.A. Zhmud', (2021) Systematic approach to the interpretation of Hubble's law, *Avtomatika i Programmnaya Ingeneriya*, No. 1(35), P. 146-164.
- [167] P.I. Gladkikh, A.S. Mazmanishvili, L.V. Reprincev, P.I. Filipov, Ballistic experiment with photons of sinchrotronic radiation, Kharkov: KhPhTI, 77-41, 1977.
- [168] V.A. Kuligin, "Brilliant mathematical formalism" with "ghosts", <http://www.trinitas.ru/rus/doc/0016/001g/00163903.htm>  
[In English: V.A. Kuligin. The Principle of Least Action in Special Relativity Theory. Galilean Electrodynamics, Vol. 12, Special Issues 2, 2001.]
- [169] A.K. Maneev, **To the Criticism of Justification of the Relativity Theory**, (Minsk: Izdatel'stvo AN, 1960).
- [170] D.Ja. Martynov, **Course of General Astrophysics**, (Moscow: Nauka, 1971, p. 310-319).

- [171] L.A. Pokhmel'nykh, **Fundamental Mistakes in Physics and the Real Electrodynamics**, (Moscow: OOO IPC "Maska", 2012, 354 p.).
- [172] K.A. Rybnikov, **History of Mathematics**, (Moscow: Moscow State University Publishing House, 1994). [In Russian]
- [173] V.P. Rykov, **Introduction to ASD. Nonrelativistic Clarification of Newton's Dynamics**, (Saint-Petersburg: Svoe Izdatel'stvo, 2022, 332 p.).
- [174] S.A. Semikov, **Ritz's Ballistic Theory and the Picture of the Universe**, (N.Novgorod: OOO "Stimul-ST", 2010).
- [175] G.I. Shipov, **Theory of physical vacuum**, (Moscow: firma "NT-Centr", 1993).

In English:

- [176] H. Ahmar, G. Amato, J.V. Kadeisvili, J. Manuel, G. West, O. Zogorodnia, Additional experimental confirmation of Santilli's isoredshift and the consequential lack of the universe expansion, *Journal of Computational Methods in Sciences and Engineering*, **13** (2013), No. 3-4, 321-357. <http://www.santilli-foundation.org/docs/IRS-confirmations-212.pdf>
- [177] S. Artekha, A. Chubykalo, A. Espinoza, (2020) Dark matter, dark energy and related topics in theoretical physics, **Hadronic Journal**, **43**, P. 61-77.
- [178] B. Bertotti, L. Iess, P. Tortora, A test of general relativity using radio links with the Cassini spacecraft, *Nature* **425** (2003), 374-376.



- [179] V.L. Bychkov, F.S. Zaitsev, *Matematicheskoe modelirovanie elektromagnitnykh i gravitacionnykh yavlenij po metodologii mekhaniki sploshnoj sredy (Mathematical modeling of electromagnetic and gravitational phenomena on the methodology of continuum mechanics)*, MAKS PRESS, Moscow (2019), 640 p.
- [180] S.J. Crothers, General Relativity – a Theory in Crisis, Global Journal of Science Frontier Research Physics and Space Science, **12** (2012), Issue 4.
- [181] T. Damour, G. Esposito-Farèse, Testing gravity to second post-Newtonian order: A field-theory approach, Phys.Rev.D **53** (1996), 5541.
- [182] L. Iess, G. Giampieri, J.D. Anderson, B. Bertotti, Doppler measurement of the solar gravitational deflection, Classical and Quantum Gravity **16** (1999), 1487.
- [183] G. Ivchenkov, Samoe vazhnoe podtverzhdenie OTO ili chto izmeril lord Eddington v 1919 (The most important confirmation of GTR or what Lord Eddington measured in 1919), <http://www.elibrary-antidogma.narod.ru/bibliography/eddingon.htm>
- [184] O.D. Jefimenko, *Gravitation and Cogravitation*, Electret Scientific, Star City (2006).
- [185] M. Kramer et al., Test of general relativity from timing the double pulsar, Science **314** (2006), 97-102.
- [186] D.E. Lebach et al., Measurement of the solar gravitational deflection of radio waves using very-long-baseline interferometry, Phys.Rev.Lett. **75** (1995) 1439.
- [187] D.S. Robertson, W.E. Carter, W.H. Dillinger, New measurement of solar gravitational deflection of radio signals using VLBI, Nature **349** (1991), 768.

- [188] R.M. Santilli, *Inconsistencies of general relativity and their apparent resolution via the Poincare invariant isogravitation*, Preprint Institute for Basic Research IBR-TPH-03-05 (2005). <http://www.i-b-r.org/Inconsist-Gravitation.pdf>
- [189] R.M. Santilli, *Hadronic Mathematics, Mechanics and Chemistry, Vol. 1, Limitations of Einstein's Special and General Relativities, Quantum Mechanics and Quantum Chemistry*, International Academic Press (2008).
- [190] R.M. Santilli, Nonlinear, Nonlocal and Noncanonical Isotopies of the Poincare' Symmetry, *Moscow Phys. Soc.* **3** (1993), 255-280. <http://www.santilli-foundation.org/docs/Santilli-40.pdf>
- [191] R.M. Santilli, Partons and Gravitation: some Puzzling Questions, *Annals of Physics* **83** (1974), 108-157. <http://www.santilli-foundation.org/docs/Santilli-14.pdf>
- [192] R.M. Santilli, Representation of galactic dynamics via isoshifts without universe expansion, dark matter and dark energy, *American Journal of Modern Physics*, **4** (2015), No. 2, 26-43. <https://doi.org/10.11648/j.ajmp.20150402.11>
- [193] R.M. Santilli, Rudiments of IsoGravitation for Matter and its IsoDual for AntiMatter, *American Journal of Modern Physics*, **4** (2015), No. 5-1, 59-75. <https://doi.org/10.11648/j.ajmp.s.2015040501.18>
- [194] I.I. Shapiro, C.C. Counselman, R.W. King, Verification of the principle of equivalence for massive bodies, *Phys.Rev.Lett.* **36** (1976), 555.
- [195] J.H. Taylor, A. Wolszcan, T. Damour, J.M. Weisberg, Experimental constraints on strong-field relativistic gravity, *Nature* **355** (1992), 132-136.
- [196] S.A. Tolchel'nikova-Murri, Radarnye nablyudeniya Venery kak prakticheskaya proverka spetsial'noi teorii otnositel'nosti

- (Venus's radar observations as a practical test of the special theory of relativity), *Izvestiya VUZov. Geodeziya i aerofotos'emka* **6** (2001), 85-108.
- [197] S.A. Tolchelnikova-Murri, The radar observations of Venus and some problems of the STR, *Proc. Galileo back to Italy, Atti del Convergnio Internazionale*, pp. 81-94, Andromeda, Bologna (1999).
- [198] S.G. Turyshev, Experimental tests of general relativity: recent progress and future directions, *Phys. Usp.* **52** (2009), 1-27.
- [199] J.G. Williams, X.X. Newhall, J.O. Dickey, Relativity parameters determined from lunar laser ranging, *Phys.Rev.D* **53** (1996), 6730.
- [200] J.G. Williams, S.G. Turyshev, D.H. Boggs, Progress in lunar laser ranging test of relativistic gravity, *Phys.Rev.Lett.* **93** (2004), 261101.

## Common Internet-resources:

- [201] <http://www.antidogma.ru/library/index.html>
- [202] <http://www.elibrary-antidogma.narod.ru/bibliography/eddington.htm>
- [203] <http://www.ritz-btr.narod.ru/>
- [204] <http://www.sceptic-ratio.narod.ru/>
- [205] <http://www.naturalphilosophy.org/site/cnps-memes/>
- [206] <http://www.antidogma.ru/library/firsts.html>
- [207] <http://newfiz.info/gra-opus.htm>